



INSPIRAIR® COMPACT

ERV

E130-HR-M-N

ENERGY RECOVERY VENTILATOR

135 CFM at 0.20 in.w.g (ESP)



UNIT

CORE

PRODUCT DESCRIPTION

The ideal in-suite ventilation solution for high-rise construction, the E130-HR-M-N delivers exceptional performance in a compact, easy-to-install package only 9-1/4" in height. Easily concealed in a drop-ceiling or soffit, the E130-HR-M-N has been thoughtfully engineered for apartments, condos, and all dwellings that use concrete-slab construction. The E130-HR-M-N produces approximately **135 CFM** at 0.20 in.w.g (ESP), enough for even the largest units in multi-family construction.

The E130-HR-M-N includes Aldes' exclusive FLEXControl, electronic calibration that eliminates the need for balancing dampers and improves overall efficiency. Cold Supply Air Prevention (CSAP) stops air distribution to the dwelling for 135-minute cycles if the supply air temperature is below freezing, reducing the risk of damage to downstream equipment.



Recovery Core

Material: High-latent-transfer (HLT)

Casing

Material: Pre-painted 24-gauge galvanized steel

Drain Connection: None

Duct Connections: 5" (127 mm)

Insulation: 1" (25 mm) Fiberglass with FSK and polystyrene

Length: 24-1/8" (613 mm)

Height: 9-1/4" (235 mm)

Width: 22-1/4" (565 mm)

Weight: 35 lbs (16 kg); Shipping Weight: 41 lbs (19 kg)

Supply Damper: Motorized; Exhaust Damper: Gravity



Mounting

Ceiling mount brackets (included) and optional chains (P/N 609051).



Electrical requirement

120 VAC, 60 Hz, 1.6 A, 192 W



Frost control

Automatic timed recirculation

Cycles controlled by a temperature sensor when the outdoor temperature drops below 14°F (-10°C)



Filters

Type : 2 Washable Foam 20 ppi (P/N: 612405)

Optional (sold separately): Washable MERV8 (P/N: 683961), or High Efficiency/MERV13 Equivalent (P/N: 612407)



Blowers

Two motorized impeller (forward-curved)

KEY FEATURES

Electronically and independently adjustable supply and exhaust blowers (FLEXControl)

Forward-curved impellers on totally enclosed motors

Horizontal configuration for flexible mounting

Drainless for simplified installation

Easy access to core and filters for cleaning

Multiple low-voltage controller options

Acoustic Performance

Airflow	Radiated	Supply Air	Exhaust Air
50 CFM	32 dBA	27 dBA	20 dBA
125CFM	44 dBA	41 dBA	30 dBA

Dimensions

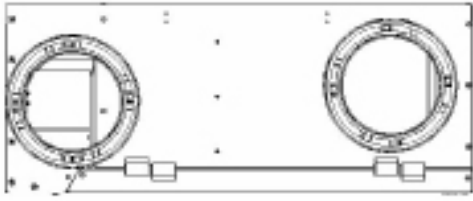

OPTIONAL FILTERS
(SOLD SEPARATELY)
MERV8:
add 0.1" w.g.
High Efficiency:
add 0.2" w.g.

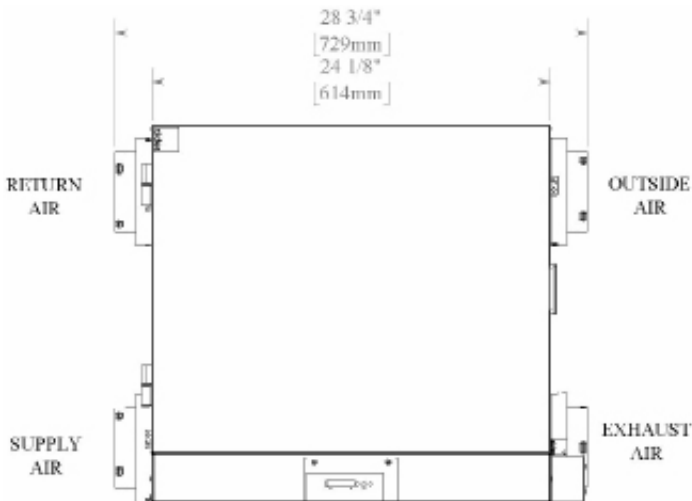
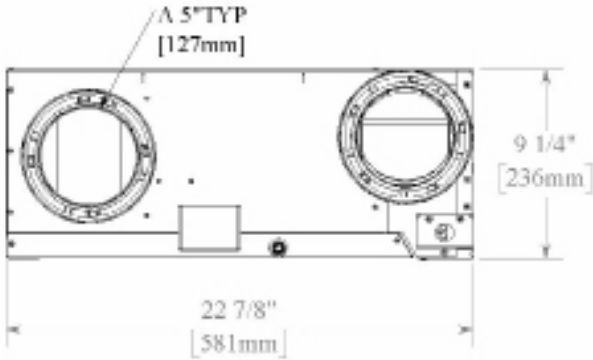

Project:	
Location:	
Model #:	
Quantity:	
Submitted By:	
Date:	
Architect:	
Engineer:	
Contractor:	
Comments:	

Controls

Low voltage dry contact (24VAC) for interlock with heating/cooling systems.

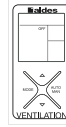

Digital Multifunction Control (#611242-FC)

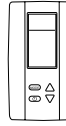

LCD Electronic Multifunction Control (P/N 611227)



20/40/60 Minute Timer (P/N 611228)



Speed Control (Low/Intermittent/High) (P/N 611229)

Performance

Recovery Performance – E130-HR-M-N

Outside Air Temperature		Net Airflow		Power Consumed (W)	Sensible Recovery Efficiency	Adjusted Sensible Recovery Efficiency	Latent Recovery / Moisture Transfer	Total Recovery Efficiency
°F	°C	CFM	L/s					
Heating								
32	0	51	24	60	71%	79%	67%	--
32	0	65	31	76	67%	75%	62%	--
32	0	100	47	132	61%	69%	54%	--
-13	-25	53	25	88	55%	59%	57%	--
Cooling								
95	35	51	24	64	--	--	47%	48%

E130-HR-M-N-N Ventilation Performance

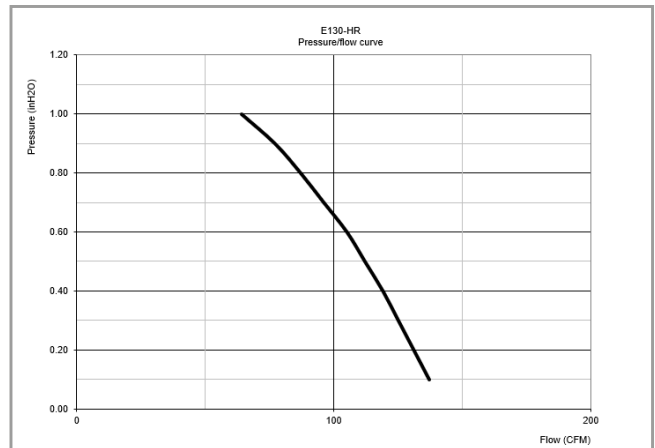

For more information, contact your Aldes sales advisor, visit aldes-na.com, call 1.800.255.7749, or find us on



©2022 American ALDES Ventilation Corporation and ALDES Canada. All Rights Reserved. Reproduction or distribution, in whole or in part, of this document, in any form or by any means, without the express written consent of American ALDES Ventilation Corporation and/or ALDES Canada, is strictly prohibited. The information contained within this document is subject to change without prior written notice.

Corporation and/or ALDES Canada, is strictly prohibited. The information contained within this document is subject to change without prior written notice.