



INSPIRAIR® COMPACT

HRV

H80-HF

HEAT RECOVERY VENTILATOR

73 CFM at 0.20 in.w.g (ESP)



UNIT

CORE

PRODUCT DESCRIPTION

The energy efficient balanced in-suite ventilation solution ideal for multi-unit residential buildings, the H80-HF delivers superior heat recovery performance in a compact, easy-to-install package only 9 inches (230 mm) in height. Easily concealed in a drop-ceiling or soffit, this unit has been thoughtfully engineered for apartments, condominiums, and other dwellings.

The H80-HF exchanges **73 CFM** of air at 0.2 in.w.g (ESP), perfect for smaller dwellings in multi-unit residential buildings. The H80-HF includes Aldes' exclusive FLEXControl, electronic calibration that eliminates the need for balancing dampers and maximizes overall efficiency. Cold Supply Air Prevention (CSAP) stops air distribution to the dwelling for 135-minute cycles if the supply air temperature is below freezing, reducing the risk of damage to downstream equipment.

KEY FEATURES

Up to 70% sensible recovery efficiency, a great choice for LEED-certified buildings

Hassle-free balancing using the balancing chart, pressure taps in the door, and the independently adjustable supply and exhaust blowers (FLEXControl)

Unique compact door allows easy access to the washable MERV 6 filters



Recovery Core

Material: Polypropylene sensible heat-recovery core

Casing

Material: 24-gauge galvanized steel

Drain Connection: 0.5" (13 mm)

Duct Connections: 5" (127 mm)

Insulation: 1" (25 mm)

Width: 22" (559 mm)

Height: 9" (230 mm)

Height: 27" (686 mm)

Weight: 35 lbs (16 kg); Shipping Weight: 40 lbs (18 kg)



Mounting

Ceiling mount brackets (included) and optional chains (P/N 609051).



Electrical requirement

120 VAC, 60 Hz, 0.8 A, 144W (MAX)

Cord Set: 36" (914 mm) with ground



Frost control

Automatic timed integral exhaust defrost

Activated by a sensor when the outdoor temperature drops below 23°F (-5°C)



Filters

Type : MERV 6 (Two replacement filters, P/N: 612415)



Blowers

Two motorized impeller (backward-inclined)

Dimensions

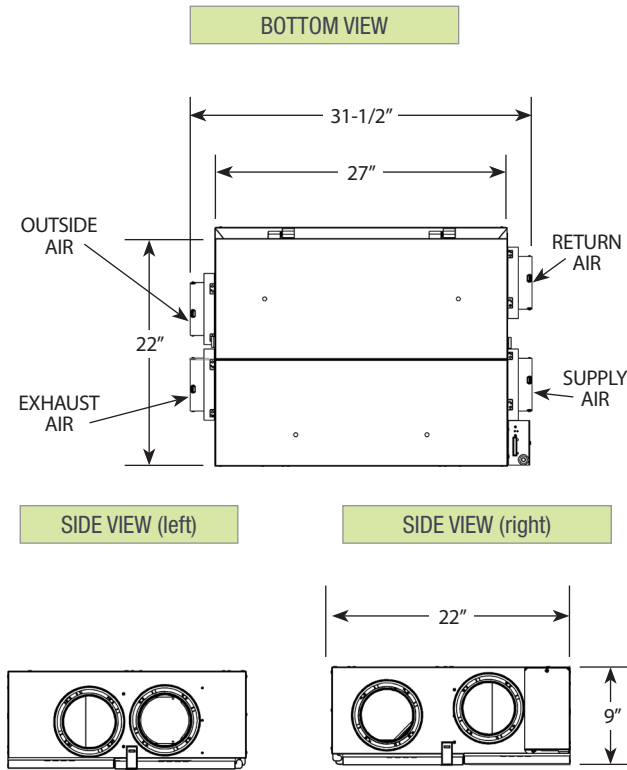

Controls

Low voltage dry contact (24VAC) for interlock with heating/cooling systems.

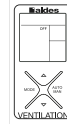

Digital Multifunction Control (#611242-FC)

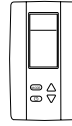

LCD Electronic Multifunction Control (P/N 611227)



20/40/60 Minute Timer (P/N 611228)



Speed Control (Low/Intermittent/High) (P/N 611229)



Performance

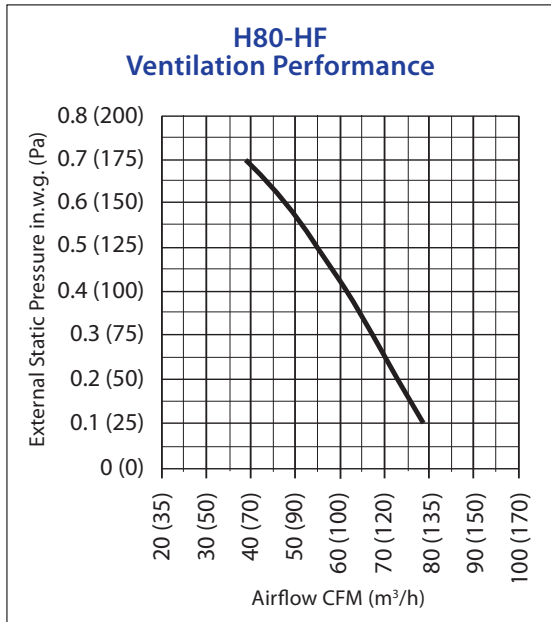

Recovery Performance – H80-HF

Supply Temperature		Net Airflow		Power Consumed (W)	Sensible Recovery Efficiency	Adjusted Sensible Recovery Efficiency
°F	°C	CFM	L/s			
32	0	55	26	32	70%	74%
32	0	66	31	46	67%	71%
32	0	81	38	62	64%	69%

Acoustic Performance

Airflow	Radiated	Supply Air	Exhaust Air
55 CFM	34 dBA	34 dBA	23 dBA
61 CFM	42 dBA	40 dBA	33 dBA

Based on HVI Publication 915, using insulated flexible duct.

For more information, contact your Aldes sales advisor, visit aldes-na.com, call 1.800.255.7749, or find us on



©2021 American ALDES Ventilation Corporation and ALDES Canada. All Rights Reserved. Reproduction or distribution, in whole or in part, of this document, in any form or by any means, without the express written consent of American ALDES Ventilation Corporation and/or ALDES Canada, is strictly prohibited. The information contained within this document is subject to change without prior written notice.

Corporation and/or ALDES Canada, is strictly prohibited. The information contained within this document is subject to change without prior written notice.