



AIRFLOW AND ZONE CONTROL



MR MAX

ACCURATE AIRFLOW

TECHNICAL DOCUMENTATION

Use in centralized systems; **AUTOMATICALLY** regulates airflow regardless of other actions occurring in the system, airflow can be reliably maintained over a **WIDE RANGE OF PRESSURE**, no need for expensive sensors or controls.

MR MAX

The model MR MAX Constant Airflow Regulator is a modulating orifice that automatically regulates airflows in duct systems to constant levels regardless of the variations affecting the ductwork, and without the use of electric or pneumatic sensors or controls.

The MR MAX can easily be inserted between two sections of round ductwork to maintain a reliably constant airflow over a wide range of differential pressure. The MR MAX is an ideal solution for meeting rooms, classrooms, and concert halls. The MR MAX will regulate airflow in supply, return, or exhaust duct systems in both low- and high-pressure installations.

MR MAX is available in a variety of sizes with airflow range from 25 to 2355 CFM to meet a wide range of airflow requirements.



KEY DETAILS

- 9 Diameters: 3", 4", 5", 6", 8", 10", 12", 14", and 16"
- Airflow values from 25 to 2355 CFM (40 to 4000 m³/h)
- Operating Pressure Range: 0.2 to 4.0 in. w.g. (50 to 1000 Pa)*
- Recommended Air Speed: 885 FPM (4.5 m/s)
- Accuracy within $\pm 10\%$ for nominal airflow > 60 CFM (100 m³/h)

*The MR MAX controls via a minimum differential pressure that depends on the airflow (see diagram) up to a maximum differential pressure of 4.0 in.w.g. (1000 Pa) within the stable control range.

MAINTENANCE

All components are maintenance-free and corrosion-proof under normal conditions. The device and ductwork must be accessible to enable adjustment and maintenance.

WARRANTY

Guaranteed for five (5) years, from date of shipment, against all defects in material or workmanship, provided that the material has been installed and used under normal conditions. This warranty is limited to the repair or replacement of the material.

CONSTRUCTION

The MR MAX is constructed of a laser-welded, galvanized steel body, a translucent plastic control device, and a double-lip airtightness seal around the circumference to ensure a tight, no-leak fit. The integral control device is comprised of an aluminum damper and a stainless steel spring and shaft fitted to PTFE (polytetrafluoroethylene) bearings. A pneumatic piston damper prevents overshoot and oscillation of the control damper and ensures an accurate response and control behavior. Each MR MAX is designed and produced for control of air in temperatures ranging from -22° to 212°F (-30° to 100°C).



1. Laser-welded galvanized steel body.
2. Control device comprised of an aluminum damper and a stainless steel spring and shaft fitted to PTFE (polytetrafluoroethylene) bearings.
3. Double-lip seal.
4. Translucent plastic control device.

When connecting to the main duct, a straight-flow section of at least 2.5 times the diagonal must be maintained and the branch point must be rounded. If the controller is attached directly to the duct, a perforated sheet with 20% blockage should be used.

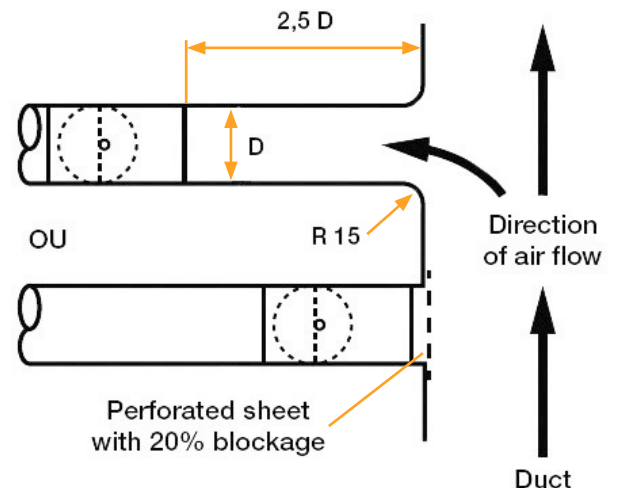

INSTALLATION

Mounting can be horizontal or vertical. The MR MAX orientation must correspond to the airflow direction indicated on the device, but the position of the damper does not affect performance.

The exact balancing of the control damper is ensured by a counterweight arranged vertically on the control damper, which ensures an accurate control response in all orientations. The flow profile in front of the flow controller should be cross-section-filling, since unfavorable flow conditions (such as asymmetric flow, deflection around sharp edges, etc.) can negatively affect the response and control behavior.

4

AIRFLOW AND ZONE CONTROL MR MAX

TYPICAL SPECIFICATION

Model MR MAX Adjustable Constant Airflow Regulators by ALDES, shall operate solely on duct pressure and require no external power supply. Each regulator shall be capable of being field adjusted to the required airflow setpoint, as indicated on the schedule, by manual adjustment of the control device using an Allen/Hex key. The device shall be rated for use in air temperatures ranging from -22° to 212°F (-30° to 100°C).

MR MAX Adjustable Constant Airflow Regulators shall be installed in tight ducting systems in accordance with all applicable codes and manufacturer's instructions.

DIMENSIONS & WEIGHT

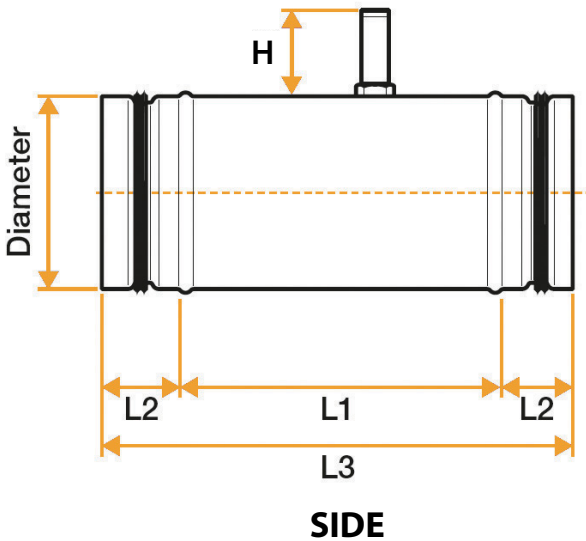

Part Number	Ø Diameter	L1	L2	L3	H	Weight
11016389	3" (80 mm)	5.31" (135 mm)	1.57" (40 mm)	8.46" (215 mm)	2.75" (70 mm)	1.32 lbs (0.6 kg)
11016390	4" (100 mm)	6.69" (170 mm)	1.57" (40 mm)	9.84" (250 mm)	2.76" (70 mm)	1.32 lbs (0.6 kg)
11016391	5" (125 mm)	6.69" (170 mm)	1.57" (40 mm)	9.84" (250 mm)	2.76" (70 mm)	1.765 lbs (0.8 kg)
11016410	6" (150 mm)	6.69" (170 mm)	1.57" (40 mm)	9.84" (250 mm)	2.76" (70 mm)	2.43 lbs (1.1 kg)
11016393	8" (200 mm)	9.45" (240 mm)	1.57" (40 mm)	12.60" (320 mm)	2.76" (70 mm)	3.97 lbs (1.8 kg)
11016394	10" (250 mm)	9.45" (240 mm)	1.57" (40 mm)	12.60" (320 mm)	2.76" (70 mm)	5.51 lbs (2.5 kg)
11016395	12" (300 mm)	8.66" (220 mm)	3.50" (89 mm)	15.67" (398 mm)	4.33" (110 mm)	11.02 lbs (5.0 kg)
11016397	14" (355 mm)	11.81" (300 mm)	2.36" (60 mm)	16.54" (420 mm)	4.33" (110 mm)	12.13 lbs (5.5 kg)
11016396	16" (400 mm)	11.81" (300 mm)	2.36" (60 mm)	16.54" (420 mm)	4.33" (110 mm)	16.53 lbs (7.5 kg)

PERFORMANCE

The MR MAX controls airflow accurately to within $\pm 10\%$ for nominal airflow > 60 CFM ($100 \text{ m}^3/\text{h}$) and ± 5 CFM ($10 \text{ m}^3/\text{h}$) for nominal airflow < 60 CFM ($100 \text{ m}^3/\text{h}$) throughout the target operating pressure range of 0.2 to 4.0 in. w.g. (50 to 1000 Pa). The MR MAX operates via a minimum differential pressure that depends on the airflow up to a maximum differential pressure of 4.0 in. w.g. (1000 Pa) within the stable control range*. The MR MAX will regulate airflow to the range in the range of 25 to 2355 CFM (40 to $4000 \text{ m}^3/\text{h}$). It will operate in the air speed range of 100 to 1575 FPM (0.5 to 8 m/s). The ideal air velocity is 885 FPM (4.5 m/s), and the speed should not drop below 530 FPM (2.7 m/s).

*The MR MAX controls via a minimum differential pressure that depends on the airflow (see diagram) up to a maximum differential pressure of 4.0 in.w.g. (1000 Pa) within the stable control range.

ADJUSTING THE AIRFLOW SETPOINT

Each MR MAX comes preset to a specific airflow. The airflow setpoint can be modified, even after installation, using an Allen/Hex key, as demonstrated in the diagram below. The airflow setpoint must fall within the airflow range shown in the table below.

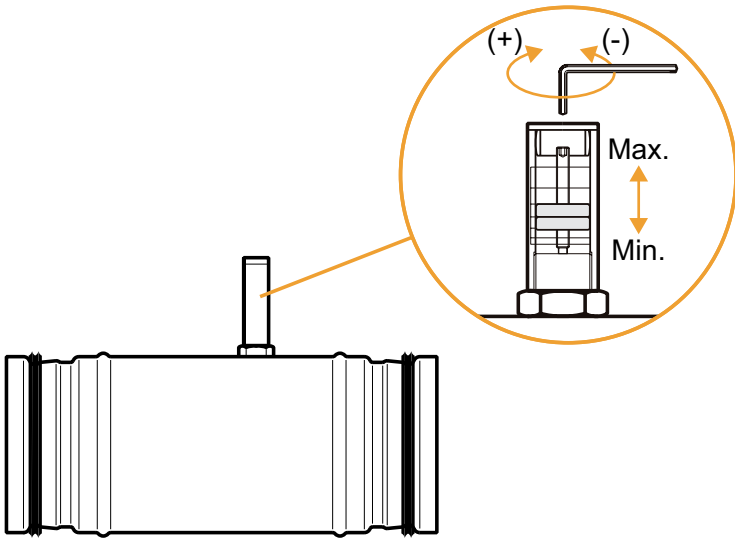

AIRFLOW RANGE		
Ø DIAMETER	PART NUMBER	AIRFLOW RANGE
3" (80 mm)	11016389	25-75 CFM (40-125 m ³ /h)
4" (100 mm)	11016390	40-130 CFM (70-220 m ³ /h)
5" (125 mm)	11016391	60-165 CFM (100-280 m ³ /h)
6" (150 mm)	11016410	100-265 CFM (170-450 m ³ /h)
8" (200 mm)	11016393	150-530 CFM (250-900 m ³ /h)
10" (250 mm)	11016394	295-940 CFM (500-1600 m ³ /h)
12" (300 mm)	11016395	470-1650 CFM (800-2800 m ³ /h)
14" (355 mm)	11016397	530-1885 CFM (900-3200 m ³ /h)
16" (400 mm)	11016396	590-2355 CFM (1400-4000 m ³ /h)

HOW THE MR MAX WORKS

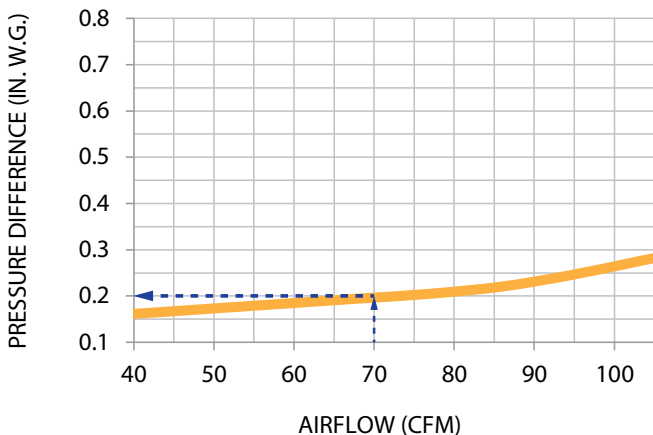

The MR MAX operates from the minimum pressure differential, which is a function of the cfm setpoint, up to the maximum pressure differential of 4.0 in. w.g.

Example Shown: MR MAX 4" with the airflow setpoint at 70 cfm, requires a minimum pressure differential of 0.2 in. w.g. and has a maximum pressure differential of 4.0 in. w.g.

FIELD OF APPLICATION

Ideal for controlling heating, ventilation and air conditioning networks with high pressure and airflow values.

APPLICATIONS OF MR MAX:

- Can be used both for air supply and exhaust.
- Airflow control ranges (see selection diagram)
- Air speed: 531-1574 FPM.
- Suitable for meeting rooms, amphitheatres, classrooms, concert halls, multi-family buildings, etc.

MINIMUM STATIC DIFFERENTIAL PRESSURE ON CONTROLLER:

The MR MAX controls via a minimum differential pressure that depends on the airflow (see diagram) up to a maximum differential pressure of 4 in. w.g. within the stable control range.

The ideal aerodynamic speed is 885 FPM and should not drop below 531 FPM.

EXAMPLE:

MR MAX diameter 6" with airflow set point 191 CFM
Air speed: 885 FPM
Minimum static differential pressure for operation: 0.2 in. w.g.

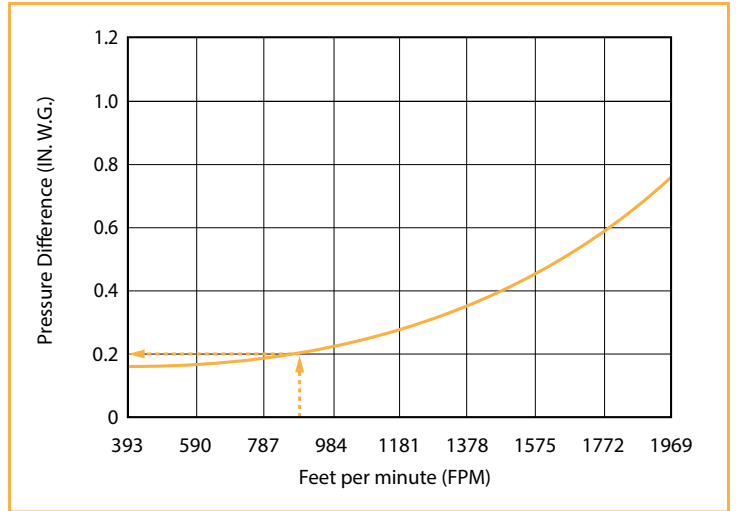

Quick-select diagram

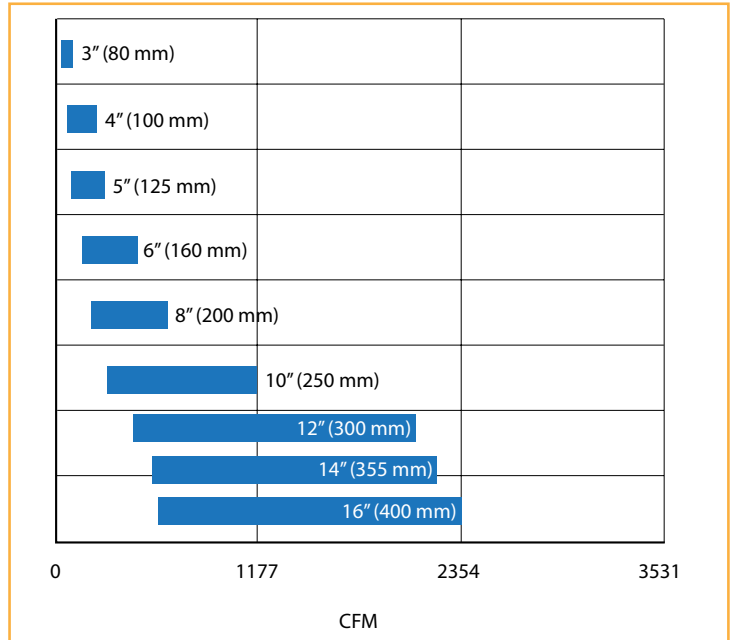

ACOUSTIC DATA

Airflow noise is highly dependent on local conditions, the radiating area of the duct (diameter and length) after the muffler, and the sound insulation. Data reported here were determined in a laboratory. The sound power can be increased by an additional sound source (e.g., a fan, unfavorable flow conditions, etc.). If this additional sound power level is 10 dB lower than the sound power level of the MR MAX, it does not cause an increase in the airflow noise generated by the controller.

Nominal Diameter	Airflow		Static Pressure Difference at the MR MAX																										
			0.4 in. w.g. (100 Pa)									1.0 in. w.g. (250 Pa)									2.0 in. w.g. (500 Pa)								
	CFM	m ³ /h	Sound Power Level/Octave Performance* L _w (dB/octave)								Total L _w total A - eval dB(A)	Sound Power Level/Octave Performance* L _w (dB/octave)								Total L _w total A - eval dB(A)	Sound Power Level/Octave Performance* L _w (dB/octave)							Total L _w total A - eval dB(A)	
			63 Hz	125 Hz	250 Hz	500 Hz	1000 Hz	2000 Hz	4000 Hz	8000 Hz		63 Hz	125 Hz	250 Hz	500 Hz	1000 Hz	2000 Hz	4000 Hz	8000 Hz		63 Hz	125 Hz	250 Hz	500 Hz	1000 Hz	2000 Hz	4000 Hz		8000 Hz
3" (80 mm)	48	82	49	47	44	41	39	39	33	32	45	51	51	50	49	48	49	44	44	54	58	58	56	55	55	56	51	51	61
	74	125	52	51	48	45	44	44	38	37	49	61	60	57	54	53	53	47	46	58	68	66	63	61	59	59	53	52	65
4" (100 mm)	40	70	40	39	38	36	35	36	30	29	41	43	45	46	46	47	49	44	43	53	49	52	52	53	54	55	50	50	60
	80	135	50	48	45	42	41	40	34	33	46	59	57	54	51	50	49	43	42	55	60	60	58	57	57	58	53	52	63
5" (125 mm)	120	200	54	52	49	47	45	45	39	38	51	63	61	58	55	54	54	48	47	59	70	68	65	62	61	60	54	53	66
	60	100	41	40	38	36	35	36	30	29	41	45	47	47	48	48	49	44	43	54	52	54	54	54	55	56	50	49	60
6" (160 mm)	110	190	51	49	46	42	41	40	34	32	46	55	54	53	51	51	51	46	45	56	61	61	59	58	57	58	52	52	63
	165	280	54	53	50	47	45	45	39	37	50	63	61	58	55	54	53	47	46	59	64	64	62	61	61	62	57	56	67
8" (200 mm)	105	180	44	43	41	39	38	38	32	31	43	48	50	50	50	51	46	45	56	55	57	57	57	57	57	58	53	51	63
	94	340	53	51	48	44	43	42	36	34	48	62	60	56	53	51	51	44	43	57	64	64	62	60	60	60	55	54	65
10" (250 mm)	294	500	57	55	52	49	47	47	40	39	52	66	64	61	58	56	55	49	48	61	72	70	67	64	62	62	56	54	68
	150	250	45	43	41	39	38	37	31	30	43	51	52	52	51	51	51	45	44	56	57	59	58	58	57	58	52	50	63
12" (300 mm)	340	575	55	53	50	46	44	44	37	36	50	64	62	58	55	53	53	46	45	59	66	66	64	62	62	62	56	56	67
	530	900	--	--	--	--	--	--	--	--	--	68	66	63	60	58	58	52	50	64	75	73	70	67	65	65	58	57	70
14" (355 mm)	295	500	48	47	45	43	41	41	35	34	47	54	56	55	55	54	55	49	48	60	61	62	62	61	61	62	56	54	66
	590	1000	57	55	52	49	47	46	39	38	52	66	64	61	57	55	55	48	47	61	69	68	67	65	64	64	59	58	69
16" (400 mm)	885	1500	--	--	--	--	--	--	--	--	--	70	68	65	62	60	60	53	52	65	77	75	72	68	67	66	60	58	72
	470	800	48	46	44	41	39	39	32	31	44	55	56	55	54	53	53	46	44	58	62	63	62	61	60	59	53	51	65
14" (355 mm)	825	1400	57	55	52	48	46	45	39	37	51	66	64	60	57	55	54	47	46	60	70	69	67	65	64	64	58	57	69
	1295	2200	--	--	--	--	--	--	--	--	--	71	69	65	62	60	59	53	51	65	77	75	72	69	67	66	60	58	72
16" (400 mm)	530	900	50	48	46	43	42	41	35	33	47	57	58	57	56	55	55	49	47	60	64	65	64	63	62	62	55	53	67
	1180	2000	59	57	53	50	48	47	40	39	53	68	66	62	59	57	56	49	47	62	72	71	69	67	66	66	60	59	71
16" (400 mm)	1885	3200	--	--	--	--	--	--	--	--	--	73	71	67	64	62	61	55	54	68	79	77	74	71	69	68	62	60	74
	590	1000	50	48	45	42	41	40	33	31	46	58	59	57	56	55	54	47	45	59	65	65	64	62	61	61	54	51	66
16" (400 mm)	1295	2200	58	56	52	49	47	46	39	37	52	67	65	61	57	55	54	48	46	61	72	71	68	66	65	65	59	57	70
			--	--	--	--	--	--	--	--	--	73	71	67	64	62	61	55	53	67	79	77	74	70	68	68	61	60	74

* Sound level in dB/octave in relation to 10⁻¹²W



For more information, contact your
Aldes sales advisor, visit aldes-na.com,
or find us on



Aldes North America
USA 800.255.7749 CAN 800.262.0916

1021 - MR MAX Brochure
©2021 American ALDES Ventilation Corporation and ALDES Canada. All Rights Reserved.
Reproduction or distribution, in whole or in part, of this document, in any form or by any means, without the express written consent of American ALDES Ventilation Corporation and/or ALDES Canada, is strictly prohibited.
The information contained within this document is subject to change without prior written notice.

