

\*Interior Model

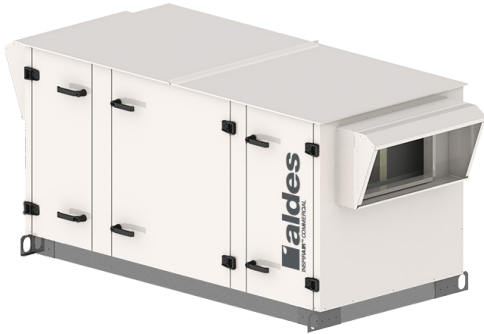

\*Exterior Model

# PW15

## INSPIRAIR® COMMERCIAL

### ENERGY RECOVERY VENTILATOR



## Nominal Capacity

500-1500 CFM

Maximum 2 in.w.g. External Static Pressure

## Wheel Exchanger

Wheel (sensible and latent heat transfer)

## Casing

- Double-wall cabinet
- 22-gauge galvanized steel interior and exterior
- Access doors with quarter-turn handles
- 22-gauge galvanized steel drain pan
- Drain Connections: 1" (25 mm) NPT
- Insulation: 1" (25 mm)

(Optional)

- Painted white baked enamel outside finish
- Supply and exhaust hoods with bird screens

## Mounting (Standard)

- Standard Platform
- 18-gauge galvanized roof curb (insulation optional)

## Electrical & Controls (Standard)

- 24 V double motor contactor with start-stop dry contact
- Non-fused disconnect (NEMA 4)
- 24 V transformer for controls
- Single point power

## Electrical

- Non-Fused disconnect
  - » Optional Fused disconnect
- 24 V transformer for controls

## Filters

Quantity: 2 supply, 2 exhaust

Type: MERV 8

Dimensions: 16" x 16" x 2" (407 mm x 407 mm x 305 mm)

(Optional)

MERV 13 Filters (single filter rack for supply/exhaust air circuit)

## Blowers & Motors

Blowers:

- Quantity: 2
- Forward-curved
- Permanently sealed and lubricated ball bearings
- Power transmission by adjustable pulleys and belts

Motors:

- Type: ODP or TEFC, Inverter duty 10:1
- Maximum Power: 2 HP
- Available Voltages:
  - » 208, 230 V / 1ph / 60Hz
  - » 208, 230, 460, 575 V / 3ph / 60Hz

## Variable Speed (Optional)

### VFD:

- Quantity: 2 (1 per air stream)
- Motor Type: ODP or TEFC
- Blower Type: Forward-curved
- Permanently sealed and lubricated ball bearings

### ECM:

- Quantity: 2 (1 per air stream)
- Plenum Type: Backward Inclined
- Permanently sealed and lubricated ball bearings
- Direct Drive
- Available Voltages:
  - » 208, 230, 460 V / 3ph / 60Hz

## Frost Prevention/Control (Optional)

If no defrost mode is selected, it is the customer's responsibility to protect the wheel from freezing as needed.

Frost control activated by a temperature reference:  
5°F (-15°C)

### Internal Pre-Heat by Electric Coil:

- Powered by unit, SSR control

### Internal Pre-Heat by Hot Water Coil:

- Controlled by the unit
- Piping connections in front or back of the unit

### Wheel Speed Variation:

- VFD on the wheel

### Exhaust Defrost:

- Supply air blower shuts down and outside air damper closes. Warm exhaust air defrosts the wheel for a factory-set duration.
- Includes motorized and insulated damper on fresh air intake (OA)

### Recirculation Defrost:

- Exhaust air blower shuts down, outside air damper closes, exhaust air damper closes, and recirculation damper (included) opens. Warm exhaust air defrosts the wheel for a predetermined amount of time (see table at right)
- Includes motorized and insulated damper on fresh air (OA) and exhaust air (EA) intake

## Post-Heat Coils

### Post-Heat by Electric Coil:

- Powered by unit, SSR control
- 0-10VDC signal by others (standard)
- 0-10VDC signal to maintain supply air temperature (optional)

### Post-Heat by Hot Water Coil:

- 0-10VDC signal by others (standard)
- 0-10VDC signal to maintain supply air temperature (optional)

## Optional Components

- Motorized and insulated damper on fresh air intake (OA) (included with exhaust, recirculation defrost and outdoor units)
- Motorized and insulated damper for exhaust port (EA) (included with recirculation defrost and outdoor units)
- Non-insulated backdraft damper for exhaust port (EA)

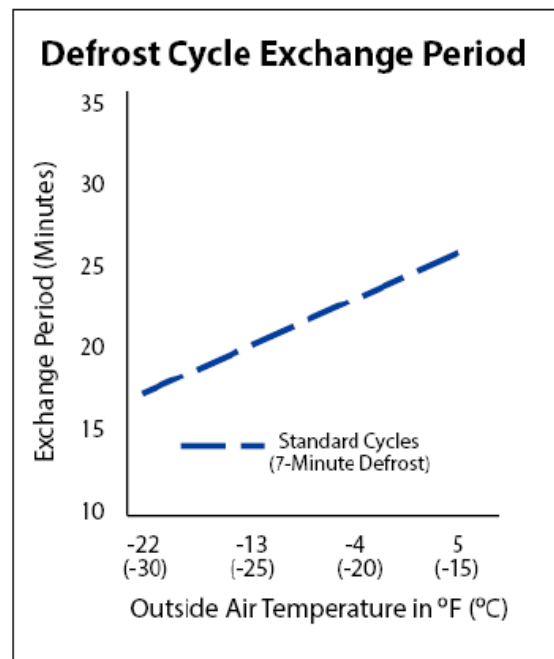

## Wheel Performance

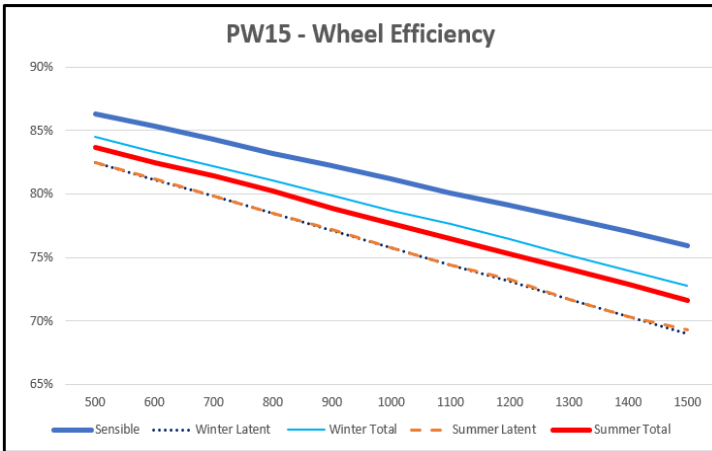

AHRI STANDARD CONDITIONS	CONDITIONS	
Outside Air Temperature	Winter	Summer
Dry Bulb	35°F (1.7°C)	95°F (35°C)
Wet Bulb	33°F (0.6°C)	78°F (25.6°C)
Exhaust Air Temperature	Winter	Summer
Dry Bulb	70°F (21.1°C)	75°F (23.9°C)
Wet Bulb	58°F (14.4°C)	63°F (17.2°C)

Note: Efficiencies are based on AHRI standard conditions.

## PW15 Configurations & Weights

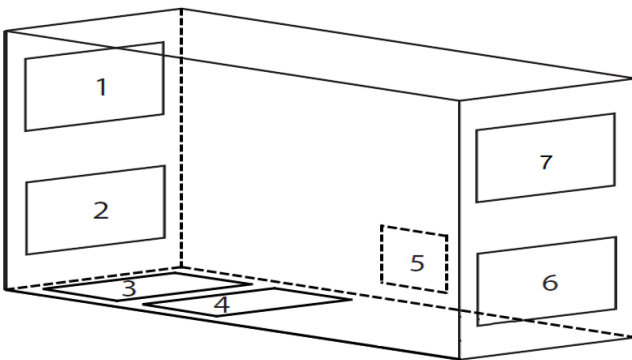

PW15 WEIGHTS & DIMENSIONS †	
Wheel Type	Wheel
Minimum Unit Weight	700 lbs (318 kg)
Maximum Unit Weight	1000 lbs (454 kg)
Minimum Shipping Weight	775 lbs (352 kg)
Maximum Shipping Weight	930 lbs (422 kg)

† Actual weight may vary by ±10%.

DUCT CONNECTION KEY	
1,3	Supply Air (SA)
2,4	Return Air (RA)
5,6	Exhaust Air (EA)
7	Outside Air (OA)

AVAILABLE CONFIGURATIONS
1-2-6-7 (indoor)
1-2-5-7 (outdoor only)
3-4-5-7 (outdoor only)

## PW15 Roof Curb Dimensions with options (Inches)

	SA	SB*	SC	SN	SO	SP	SQ	SR	SS	ST	SU	SZ
PW15	2.25	58.25	14	15.25	10	2	10	7.25	23	35.5	10.5	2

\* Add 20" to width of Roof Curb for each extension

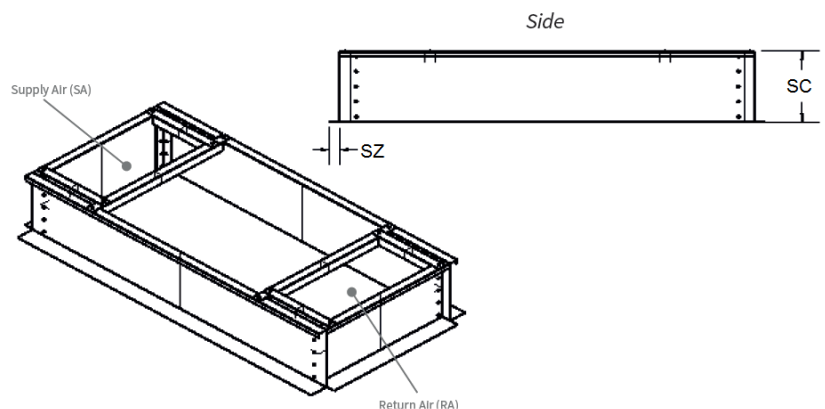
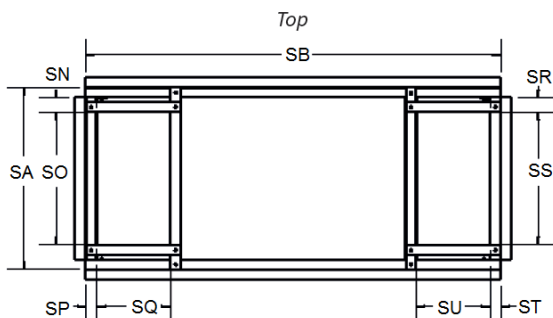

## PW15 Indoor Units Dimensions (Standard - Inches)

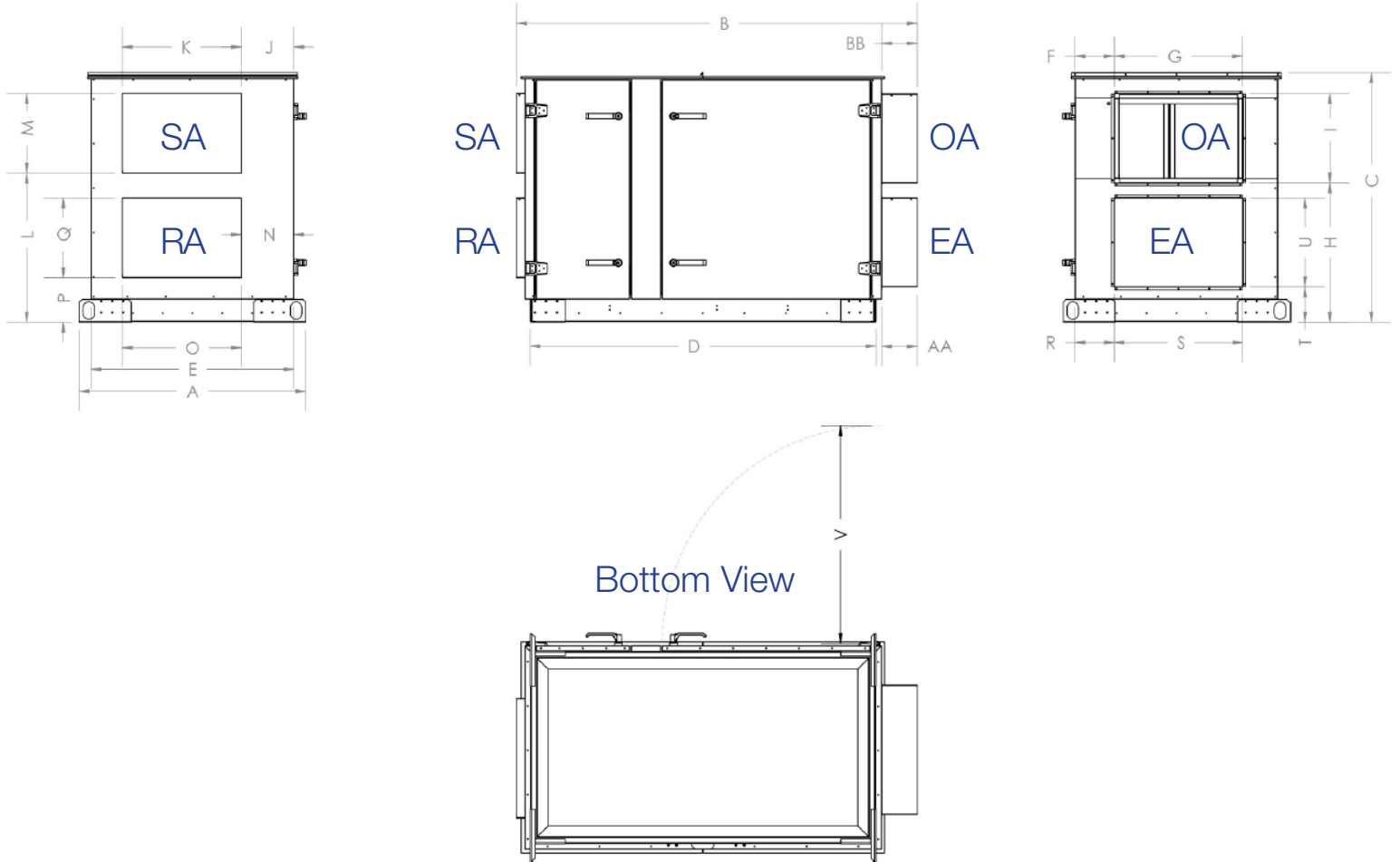

Dimension with Options (inches)												
A		B			C	D			E		F	
Overall	Bypass	Overall	1 Extension	2 Extensions		Overall	1 Extension	2 Extensions	Overall	Bypass	Overall	Bypass
41.5	N/A	73.75	93.75	N/A	44.75	62.5	82.5	N/A	34.5	N/A	8.25	N/A
G	H	I	J		K	L	M	N		O	P	Q
			Overall	Bypass				Overall	Bypass			
21.5	26.75	14.25	8.25	N/A	21.5	7	14.25	8.25	N/A	21.5	26.75	14.25
R		S	T	U	V	W	X	Y	Z	AA	AB	
Overall	Bypass											
8.25	N/A	21.5	7.25	14.25	40	N/A	N/A	N/A	N/A	7.5	7.5	

\* 1 Extension is used when adding a Post-heat coil

## PW15 Outdoor Units Dimensions (Standard - Inches)

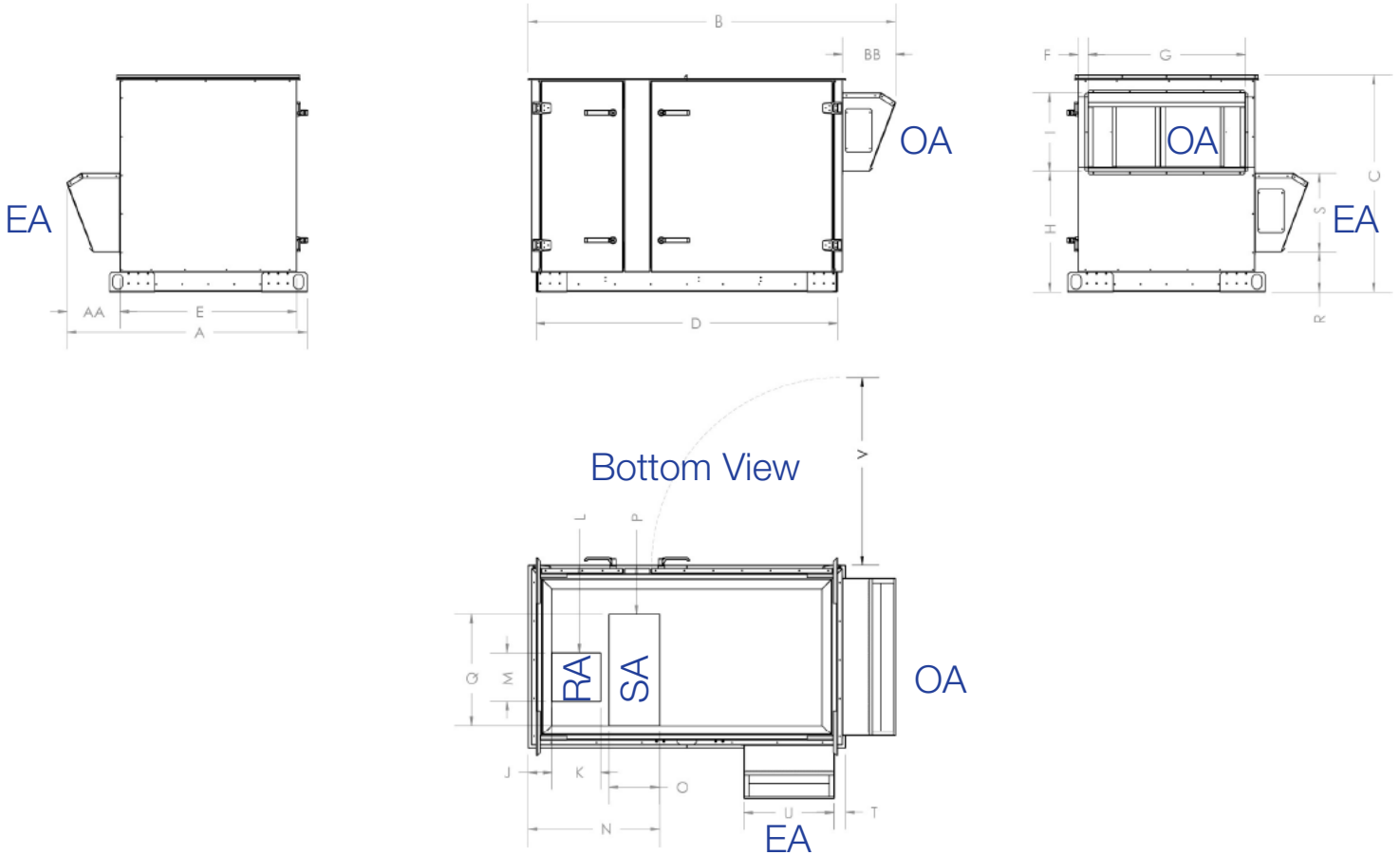

Dimension with Options (inches)												
A		B			C	D			E		F	
Overall	Bypass	Overall	1 Extension	2 Extensions		Overall	1 Extension	2 Extensions	Overall	Bypass	Overall	Bypass
50.25	N/A	76.25	96.25	N/A	44.75	62.5	82.5	N/A	34.5	N/A	1	N/A
G	H	I	J		K	L	M	N		O	P	Q
			Overall	Bypass				Overall	Bypass			
32	25	16.25	25	N/A	18.75	7.5	16.25	16.25	N/A	10	3.25	10
R		S	T	U	V	W	X	Y	Z	AA	AB	
Overall	Bypass											
8.5	N/A	23	36.75	10.5	40	N/A	N/A	N/A	N/A	11	11	

\* 1 Extension is used when adding a Post-heat coil

# Selection Information

**MODEL:** PW15  
**SERIES:** InspirAIR® Commercial  
**NOMINAL CAPACITY:** 500-1500 CFM

Standard Feature  
 Optional Feature  
*(check the box to select this option)*

**REMEMBER TO:** Send your completed selection to your ALDES Representative.

## UNIT

### CABINET FINISH

- Galvanized
- Painted

### DUCT CONFIGURATION

- 1-2-6-7 (Indoor Unit)
- 1-2-5-7 (Outdoor Unit)
- 3-4-5-7 (Outdoor Unit)

### CONFIGURATION OPTIONS

- None (Indoor Unit)
- Rooftop Installation (Outdoor Unit)
- Mirror Configuration\*  
(\*Doors are located to the opposite side)

### FROST CONTROL

- None
- Exhaust Defrost
- Recirculation Defrost
- Wheel Speed Variation
- Pre-Heat (Electrical Coil)
- Pre-Heat (Hot Water Coil)

### HEATING OPTIONS

- None
- Post-Heat (Electrical Coil)
- Post-Heat (Hot Water Coil)

## BLOWERS & MOTORS

### MOTOR TYPE

- ODP
- TEFC
- EC (208V/3p, 230V/3p and 460V/3p only)

### SPEED

- Single Speed
- VFD
- ECM (208V/3p, 230V/3p and 460V/3p only)

### FILTERS

- MERV 8
- MERV 13

### ELECTRICAL REQUIREMENTS

- 208V/1ph/60Hz
- 230V/1ph/60Hz
- 208V/3ph/60Hz
- 230V/3ph/60Hz
- 460V/3ph/60Hz
- 575V/3ph/60Hz

### DISCONNECT

- Non-fused
- Fused

## OPTIONAL ADD-ONS

- Motorized & Insulated Damper for OA
- Motorized & Insulated Damper for EA
- Non-Insulated Backdraft Damper for EA
- End-Switch on Dampers
- BacNET MSTP Controller
- BacNET IP Controller
- Remote Display Panel (with BACnet Controller Only)
- Programmable Timer (Inside Control Panel or Shipped Loose)
- Free Cooling Management
- Post-Heat Management
- Low Temperature Limit (with Post-Heat Only)
- Carbon Dioxide Sensor (Inside Unit or Wall-Mounted)
- CO2 Management
- Dry Contact For Dirty Filter Alarm
- Independent Motor Management
- Low Airflow Limit Switch
- Phase-Loss Detection
- Fan Interlock on Exhaust
- Relative Humidity Sensor
- Wheel Rotation Detection Sensor
- Mechanical Purge (Between 5° to 15°) \_\_\_\_\_
- MERV 8 Filter Set (Spare Filter Set)
- MERV 13 Filter Set (Spare Filter Set)
- Spare Belts QTY: \_\_\_\_\_

## OPERATING CONDITIONS

REQUIRED AIRFLOW (CFM) \_\_\_\_\_

EXTERNAL STATIC PRESSURE (IN.W.G.) \_\_\_\_\_

PROJECT LOCATION (CITY/TOWN) \_\_\_\_\_

For more information, contact your Aldes sales advisor, visit [aldes-na.com](http://aldes-na.com), call 1.800.255.7749, or find us on

