

# INSPIRAIR® COMPACT

## ERV

### E80-HF-N

ENERGY RECOVERY VENTILATOR  
74 CFM at 0.20 in.w.g (ESP)

Made in  
Canada

5 year  
Warranty

5 year  
Warranty

UNIT

CORE

### PRODUCT DESCRIPTION

The energy efficient balanced in-suite ventilation solution ideal for multi-unit residential buildings, the E80-HF-N delivers superior heat recovery and a latent transfer of over 65% in a compact, easy-to-install package only 9 inches (230 mm) in height. Easily concealed in a drop-ceiling or soffit, this unit has been thoughtfully engineered for apartments, condominiums, and other dwellings.

The E80-HF-N exchanges **74 CFM** of air at 0.2 in.w.g (ESP), perfect for smaller dwellings in multi-unit residential buildings. The E80-HF-N includes Aldes' exclusive FLEXControl, electronic calibration that eliminates the need for balancing dampers and maximizes overall efficiency. Cold Supply Air Prevention (CSAP) stops air distribution to the dwelling for 135-minute cycles if the supply air temperature is below freezing, reducing the risk of damage to downstream equipment.

### KEY FEATURES

No drain required with Aldes' high performance HLT crossflow ERV core technology

Up to 73% sensible recovery efficiency, a great choice for LEED-certified buildings

Hassle-free balancing using the balancing chart, pressure taps in the door, and the independently adjustable supply and exhaust blowers (FLEXControl)

Unique compact door allows easy access to the washable MERV 6 filters



### Recovery Core

Material: High-latent-transfer (HLT) fixed plate enthalpic core

### Casing

Material: 24-gauge galvanized steel

Drain Connection: None

Duct Connections: 5" (127 mm)

Insulation: 1" (25 mm)

Width: 22" (559 mm)

Height: 9" (230 mm)

Height: 27" (686 mm)

Weight: 37 lbs (17 kg); Shipping Weight: 42 lbs (19 kg)



### Mounting

Ceiling mount brackets (included) and optional chains (P/N 609051).



### Electrical requirement

120 VAC, 60 Hz, 0.8 A, 144W (MAX)

Cord Set: 36" (914 mm) with ground



### Frost control

Automatic timed integral exhaust defrost



### Filters

Type : MERV 6 (Two replacement filters, P/N: 612415)



### Blowers

Two motorized impeller (backward-inclined)

# Dimensions

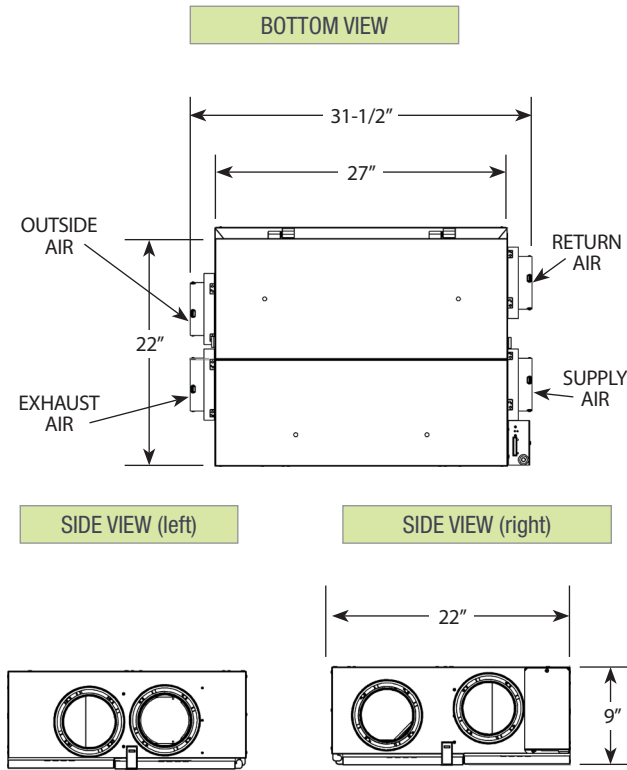

# Controls

Low voltage dry contact (24VAC) for interlock with heating/cooling systems.

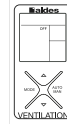

Digital Multifunction Control (#611242-FC)

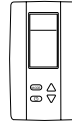

LCD Electronic Multifunction Control (P/N 611227)



20/40/60 Minute Timer (P/N 611228)



Speed Control (Low/Intermittent/High) (P/N 611229)



# Performance

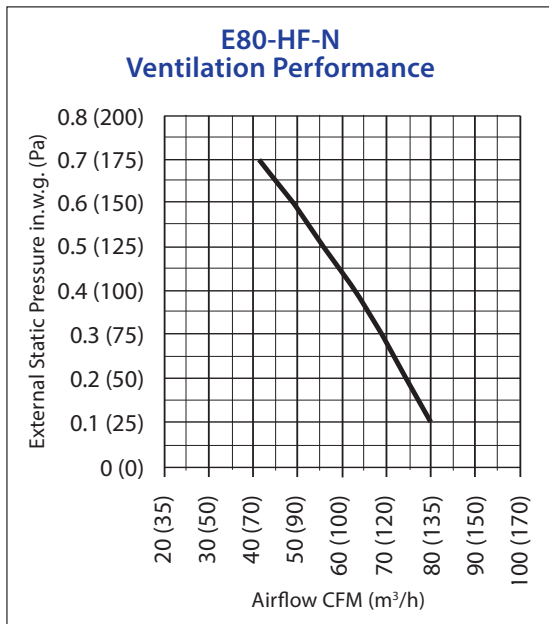

**Recovery Performance – E80-HF-N**

Supply Temperature		Net Airflow		Power Consumed (W)	Sensible Recovery Efficiency	Adjusted Sensible Recovery Efficiency	Latent Transfert	Total Recovery Efficiency
°F	°C	CFM	L/s					
32	0	55	26	32	73%	80%	0.61	--
32	0	67	32	54	70%	78%	0.59	--
32	0	80	38	66	68%	76%	0.55	--
95	35	49	23	49	n/a	74%	0.66	64%

**Acoustic Performance**

Airflow	Radiated	Supply Air	Exhaust Air
55 CFM	34 dBA	34 dBA	23 dBA
61 CFM	42 dBA	40 dBA	33 dBA

Based on HVI Publication 915, using insulated flexible duct.

For more information, contact your Aldes sales advisor, visit [aldes-na.com](http://aldes-na.com), call 1.800.255.7749, or find us on



©2021 American ALDES Ventilation Corporation and ALDES Canada. All Rights Reserved. Reproduction or distribution, in whole or in part, of this document, in any form or by any means, without the express written consent of American ALDES Ventilation Corporation and/or ALDES Canada, is strictly prohibited. The information contained within this document is subject to change without prior written notice.

Corporation and/or ALDES Canada, is strictly prohibited. The information contained within this document is subject to change without prior written notice.