

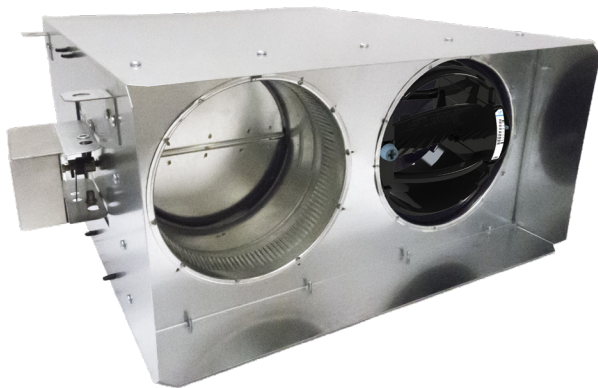

# ZRT-PDIL

## PARALLEL DAMPER IN-LINE ZONE TERMINALS



### AIRFLOW & ZONE CONTROL



## Product Description

Aldes Parallel Damper In-Line Zone Terminals (ZRT-PDIL) are designed to introduce flexibility and dynamic control to central supply or exhaust ventilation systems. Used in both large and small systems, the ZRT-PDIL regulates ventilation without the need for individual fans or traditional VAV terminal units.

Each ZRT-PDIL is a two-position, pressure-independent terminal with a control damper to regulate high limit on-demand airflow control and integral passive regulators for automatic air balancing of the continuous and boost airflow setpoints. This unique combination provides flexible control schemes without the need for expensive pneumatic, electronic, or DDC control systems.

The ZRT-PDIL is primarily used for combination low-flow indoor air quality ventilation or make-up air, and on demand high-flow spot ventilation using the same central exhaust or supply fan system. This is achieved by integrating a minimum Constant Airflow Regulator (CAR) in the terminal end panel and in-line with the branch duct. The maximum airflow is controlled by a series of 24 VAC or 120 VAC powered motorized damper(s) and a secondary CAR airflow controller. With the maximum-air motorized control damper completely closed, the continuous CAR allows steady, low-volume airflow control.

When other ZRT-PDIL are activated for on-demand control of high flow, the unpowered ZRT-PDIL will maintain the specified continuous rate through the pressure-independent CAR. Opening the ZRT-PDIL's control damper adds its calibrated boost airflow rate to the continuous setpoint.

## Construction

- Constructed of 24-gauge galvanized steel housing for durability.
- 24 VAC, 120 VAC, or 230 VAC actuator motor with spring return damper assembly.
- Gasketed damper blade ensures a tight seal preventing unwanted air leakage and noise in closed position.
- Designed for installation with slip-type duct connections.
- Access to all internal components through the screw-on access plate located at the bottom of the units.

## Maintenance

The ZRT-PDIL needs no maintenance when used in normal conditions.

## Warranty

The entire unit is guaranteed for three (3) years, from date of shipment, against all manufacturing defects, provided the material has been installed and operated per manufacturer's instructions and under normal conditions. Warranty is limited to the repair or replacement of the material upon its return freight paid to our factory. This warranty is not transferable and is limited to the original end user.

# ZRT-PDIL

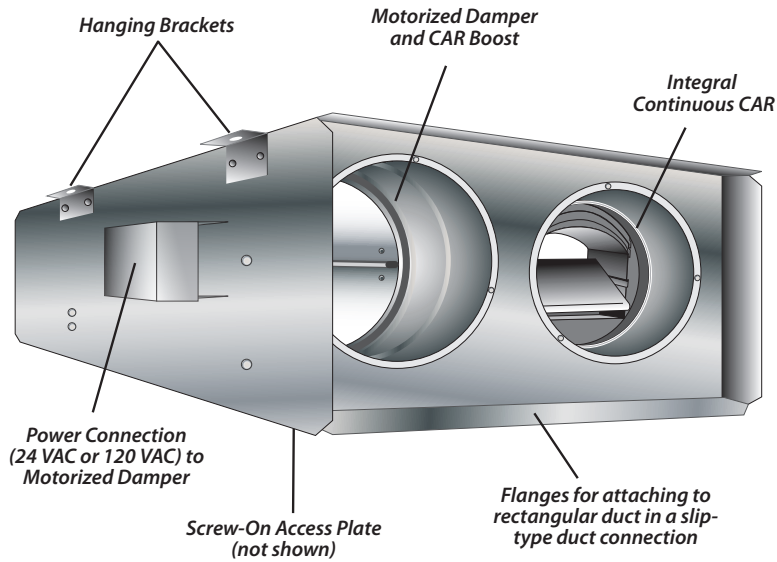

## ZRT-PDIL Dimensions

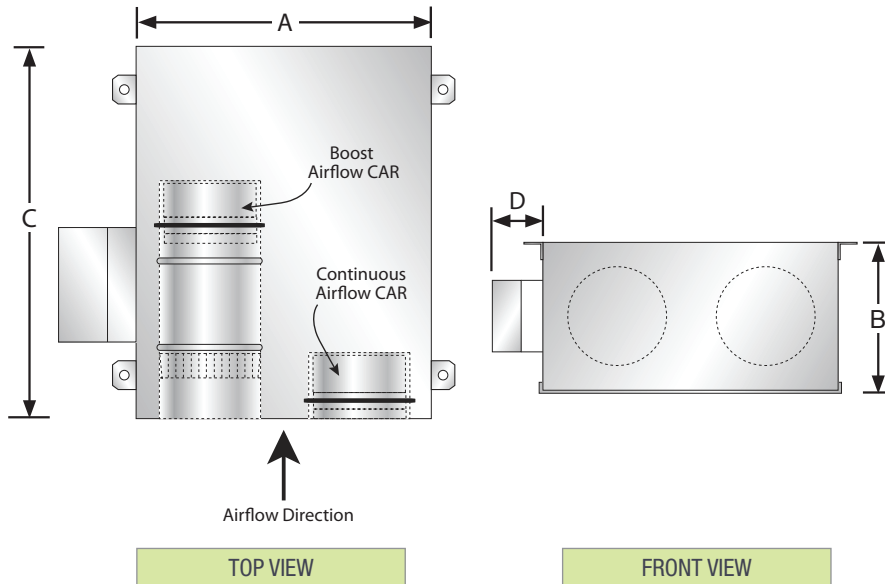

SIZE (Duct) Inches / mm	CAR Diameter		A	B	C	D
	Min	Max				
12" x 6" (300 mm x 150 mm)	4" (100 mm)	4" (100 mm)	12" (300 mm)	6" (150 mm)	19-5/8" (500 mm)	3-1/8" (80 mm)
16" x 8" (400 mm x 200 mm)	6" (150 mm)	6" (150 mm)	16" (400 mm)	8" (200 mm)	21-5/8" (550 mm)	3-1/8" (80 mm)
20" x 10" (500 mm x 250 mm)	8" (200 mm)	8" (200 mm)	20" (500 mm)	10" (250 mm)	23-5/8" (600 mm)	3-1/8" (80 mm)
24" x 12" (610 mm x 300mm)	10" (250 mm)	10" (250 mm)	24" (610 mm)	12" (300 mm)	25-5/8" (650 mm)	3-1/8" (80 mm)

## How to Specify Aldes: ZRT-PDIL

**Step 1:** Reference the model code below and performance details within this specifications sheet to select the appropriate ZRT-PDIL.

**Step 2:** Determine the required **DUCT SIZE**.

**Step 3:** Select the required **MOTOR VOLTAGE**.

**Step 4:** Select the desired **CONTINUOUS CFM** for low volume continuous ventilation.

**NOTE:** The continuous rate is always active.

**Step 5:** Select the necessary **BOOST CFM** for intermittent high-volume ventilation.

**NOTE:** The boost rate is normally off and powered on. The boost rate adds to the continuous rate. Ex. If the continuous rate is 50 CFM and the boost is 250 CFM, when powered the ZRT-PDIL will provide 300 CFM. See example below.

## Model Code Example

### PARENT MODEL

ZRT-PDIL

### DUCT SIZE

12" x 6"  
16" x 8"  
20" x 10"  
24" x 12"

### MOTOR VOLTAGE

24: 24 VAC  
120: 120 VAC

### CONTINUOUS CFM

12" x 6": 15-85 CFM  
16" x 8": 15-260 CFM  
20" x 10": 15-490 CFM  
24" x 12": 15-620 CFM

### BOOST CFM

12" x 6": 15-85 CFM  
16" x 8": 15-260 CFM  
20" x 10": 15-490 CFM  
24" x 12": 15-620 CFM

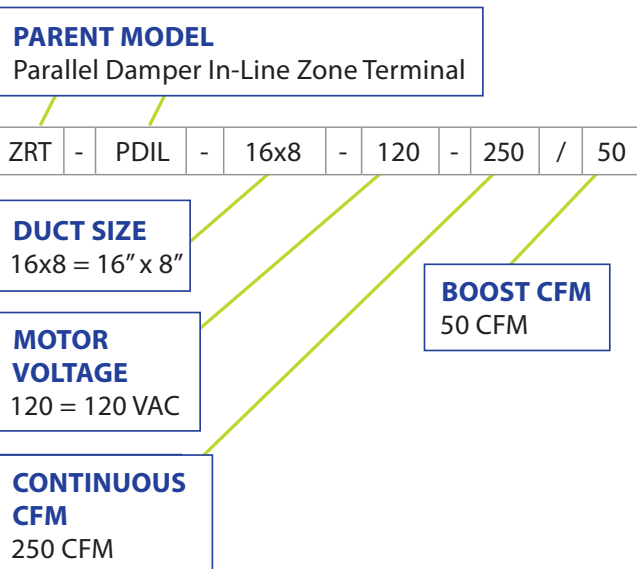

## Control

The ZRT-PDIL can be activated using a variety of control options, including dry contact switches for interlocking with other devices, on-off or timer switches, occupancy sensors, etc. Any on-off control device(s) will signal the max-flow damper to open fully, allowing for maximum ventilation control. Upon disconnecting the power, the ZRT-PDIL's integral spring will return the blade to its normally closed position to resume the continuous airflow rate and operation.

Airflow control for both boost and continuous flow rates is achieved using integral Constant Airflow Regulators (CAR). The CAR is an automatic, pressure independent modulating orifice that regulates airflows to constant levels in response to changes in duct pressure. They ideally suited for use in zone-controlled systems where duct pressures can fluctuate in response to the opening and closing of dampers, or variable volume systems.

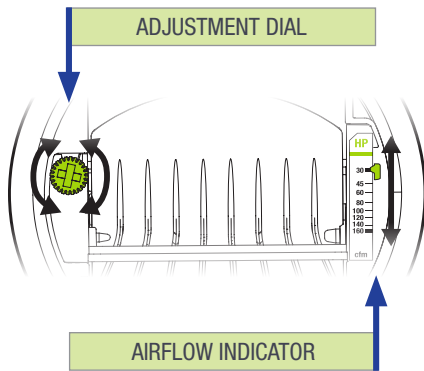

## Airflow Settings & Performance Data

Airflow rate can be set or adjusted by rotating the dial from either side. The airflow indicator will move to show the selected CFM. The airflow label has multiple defined setpoints, but the unique adjustment mechanism of the CAR3 allows for infinite adjustability between the minimum and maximum limits.

Performance charts found in the specifications sheet reflect this data, with the available range (shaded) and marked setpoints (lines). The CAR3 will maintain the airflow accurately to within +/- 10% of the indicated lines below for each marked setpoint. At the higher airflow rates, the minimum pressure required to achieve the selected airflow may exceed 0.12 in. w.g.

Airflow measurements taken at 68°F (20°C) at 1 atmosphere pressure.

### ZRT-PDIL- 4" DIAMETER (100 mm)

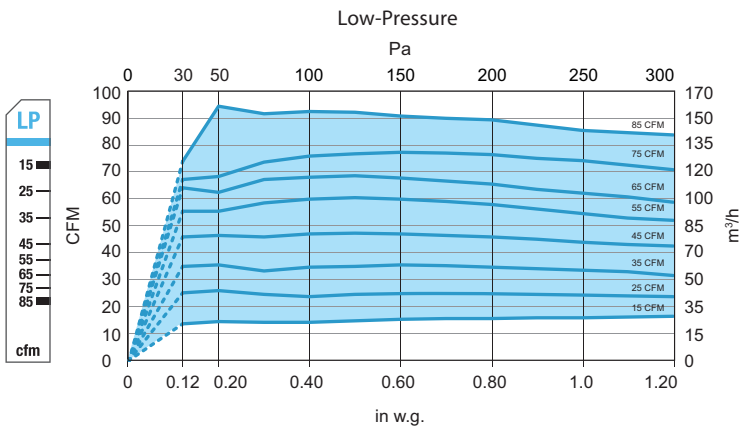

### ZRT-PDIL- 5" DIAMETER (125 mm)

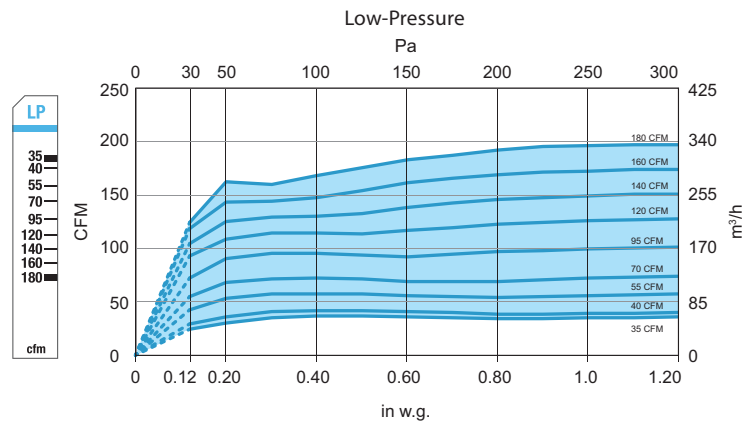

### ZRT-PDIL- 6" DIAMETER (150 mm)

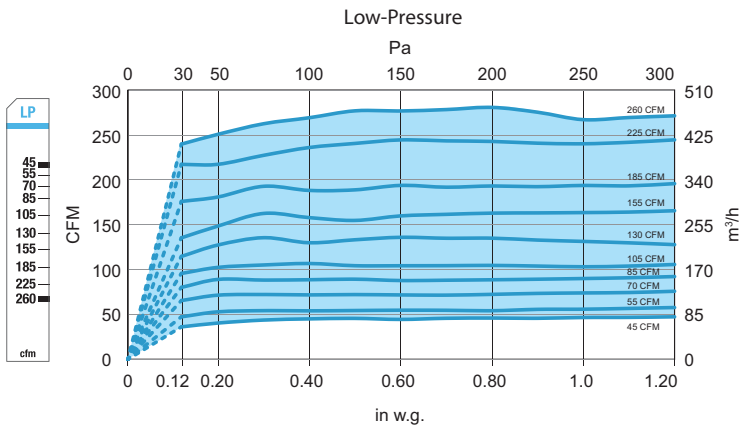

### ZRT-PDIL- 8" DIAMETER (200 mm)

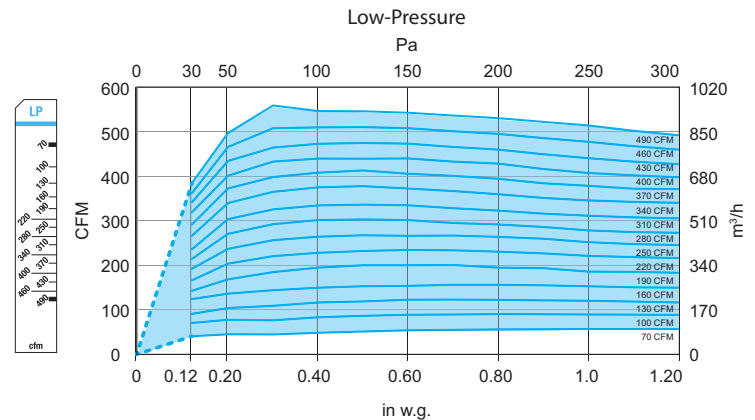

**ZRT-PDIL- 10" DIAMETER (250 mm)**

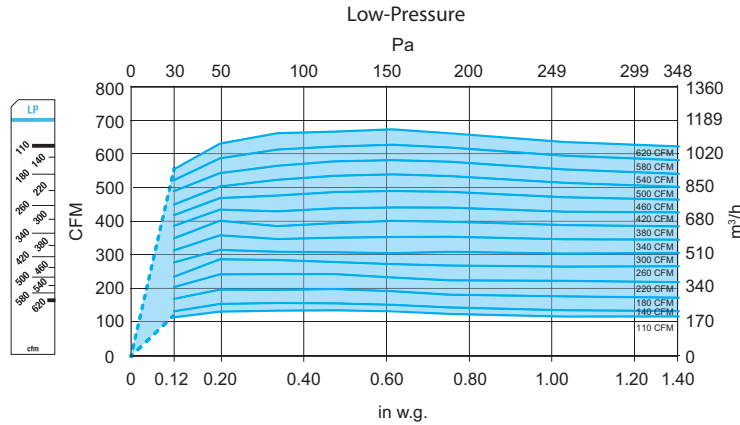

## Recommended Specification

Furnish and install model ZRT-PDIL Parallel Damper In-Line Zone Terminals by ALDES North America or approved equal. The terminals shall be of sizes and capacities and at locations scheduled on the drawings. The terminal casing shall be minimum 24-gauge G90 galvanized steel with duct flange that allows attachment of rectangular rigid ducting in a slip-type duct connection. Each terminal shall include integral, pressure-independent Constant Airflow Regulators (CAR) that provide the capability of automatically regulating airflow in both a continuous and boost setting. Each regulator shall automatically respond to changes in duct pressure to maintain specified flow rates at a constant level.

The low-volume continuous and on-demand boost Constant Airflow Regulators (CAR) shall be factory calibrated to the specified set points. Both regulators shall be capable of being adjusted in the field to any desired airflow within their noted minimum and maximum setpoints. The continuous CAR will automatically control the amount of air any time the central fan is operating. The boost CAR shall be located in series with a motorized single-blade damper operated by a long-life synchronous-drive motor with normally closed spring-return closure. When the ZRT-PDIL is powered, the motorized damper will open allowing air through the boost regulator, automatically adding the prescribed boost rate to the continuous rate during central fan operation. The damper blade shall rotate on a solid one-piece damper that pivots on permanently lubricated bearings. A permanently fixed perimeter gasket seal shall be provided to prevent air noise and leakage at the closed position.

The entire damper assembly and all operable parts shall be capable of being removed from the terminal housing from below without disconnecting duct or removing the housing. Access to all regulator and damper components shall be through an integral screw-on access plate. All terminals and/or pertinent components must be listed per UL standards and carry the UL, UR or ETL mark indicating compliance. Each ZRT-PDIL shall include all necessary mounting brackets and hardware. Installation shall be per all applicable codes and manufacturer’s instructions.

ELECTRICAL SPECIFICATIONS				
MOTOR VOLTAGE	MAXIMUM AIRFLOW DAMPER OPEN (POWERED)		MAXIMUM AIRFLOW DAMPER CLOSED (NOT POWERED)	
	24 VAC	0.36 A	6 W	0.00 A
120 VAC	0.08 A	6 W	0.00 A	0.0 W

For more information, contact your Aldes sales advisor, visit [aldes-na.com](http://aldes-na.com), call 1.800.255.7749, or find us on

