



SERIES ADVANCED COMMERCIAL
CE10000
Energy Recovery Ventilator

PRODUCT
SPECIFICATIONS
& TECHNICAL
DATA

Standard Features



Interior Unit CE10000i



Exterior Unit CE10000e

NOMINAL CAPACITY

8500-10500 CFM

CASING

Double-wall cabinet
White exterior paint, 22-gauge galvanized steel
18-gauge galvanized steel interior walls
Access doors with quarter-turn handles
Drain Connections: 1" NPT
Insulation: 2" (51 mm)

MOUNTING

On roof curb or on platform

PLATE EXCHANGER

Material: Enthalpy
Quantity: 3
Pitch: 0.13" (3.3 mm)
Dimensions: 30" x 30" x 27.5"
(762 mm x 762 mm x 699 mm)



BLOWERS

Quantity: 2

- Forward-curved
- Permanently sealed and lubricated ball bearings
- Power transmission by adjustable pulleys and belts

MOTORS

Type: Inverter duty 10:1, ODP or TEFC, EAct or Premium
Maximum Power: 20 hp
Drive Assembly/Blower: On vibration-isolating springs

FILTERS

Type: MERV 8
Quantity: 8 per circuit
Dimensions: 20" x 24" x 4" (508 mm x 610 mm x 102 mm)

ELECTRICAL & CONTROLS

- Start/stop dry contact and general alarm dry contact
- Occupancy control dry contact
- Fan interlock dry contact
- 24VAC, 20VA power available for accessories
- Access panel with non-fused disconnect (NEMA 4)
- Single-point power connection
- 120, 208, 230 V / 1ph / 60Hz
- 208, 230, 460, 575 V / 3ph / 60Hz

WARRANTY

- Core: Limited 10-year warranty
- All Other Covered Components: Limited 2-year warranty

LISTED BY



Optional Features

FROST PREVENTION/CONTROL OPTIONS

Frost control activated by a temperature reference

Set point: 14°F (-10°C)

Internal Pre-Heat by Electric Coil:

- Powered by unit
- Factory calibrated
- SCR control

Internal Pre-Heat by Hot Water Coil:

- 0-10 V signal on the control panel
- Front or back piping connections

Internal Face and Bypass Damper:

- Fresh air deviation

Defrost Cycles:

- Exhaust Only or Recirculation
- Comes with motorized and insulated damper on OA only
- See table below for temperature references

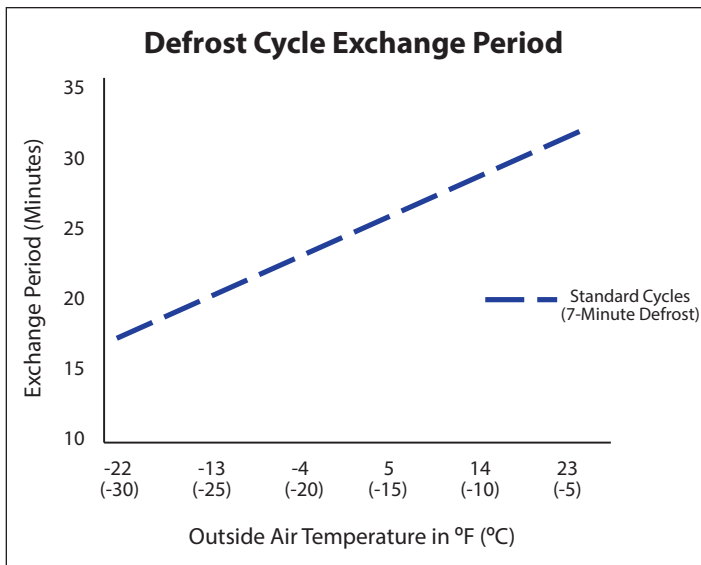

AVAILABLE OPTIONS

Cabinet Options:

- Supply and Exhaust Hoods with bird screens
- Roof Curb: 14" (356 mm) high, 18-gauge galvanized steel, insulation optional
- Front or back piping connections (drain pan and water coil and/or cooling connections)
- Pool Construction: TEFC motors, stainless steel interior, and epoxy-coated fans (NOTE: ERV not recommended for indoor pool applications)

AVAILABLE OPTIONS

Components Options:

- Final MERV 13 filters added to the fresh air circuit
- Motorized and insulated dampers (on OA and/or EA openings)
- Non-insulated backdraft damper (on EA opening only)
- Post-Heat by Electric Coil: Powered by unit
- Post-Heat by Hot Water Coil: 0-10VDC signal to maintain supply air temperature, or 0-10VDC signal by others
- Cold Water Cooling Coil: Control by others, comes with 18-gauge stainless steel drain pan
- DX Cooling Coil: All controls and condensation unit by others, comes with 18-gauge stainless steel drain pan

Blower Motor Options:

- TEFC, Premium (only available with ≥ 1.5 hp/ 3ph)
- 2-Speed motors (only available with ODP, EPAct motors)
- Programmable 2-Speed (VFD)
- Variable Frequency Drive (VFD), 0-10VDC control signal by others
- Backward-inclined blowers

Control Options:

- Economizer Cycle: Free cooling management by temperature sensor on OA (available with face and bypass damper only)
- Dirty Filters Contact: Will close a dry contact when dirty filters are detected
- Low Airflow Switch: Will open a dry contact when no airflow is detected on supply blower
- Low Temperature Limit: Unit will stop if fresh air supply is under set point (adjustable) for more than 5 minutes
- Phase Loss Detection: Unit will stop when a phase loss occurs, automatic restart (3-phase power only)
- Damper End Switch: Unit start up conditional to dampers opening
- Recirculation Dry Contact: For unoccupied mode, must select recirculation defrost option
- Terminals for OA and/or EA damper power and control (24VAC, 10VA): Included when OA/EA damper selected
- Programmable Timer
- CO₂ or Relative Humidity (RH) Sensor: Sequence of operations must be verified by factory
- BacNet Compatible Controller
 - Available Upgrades:
 - » IP Communication Network Module
 - » MS/TP Communication Network Module
 - » Remote Keypad
 - » Remote Keypad with Touchscreen

Components & Configurations

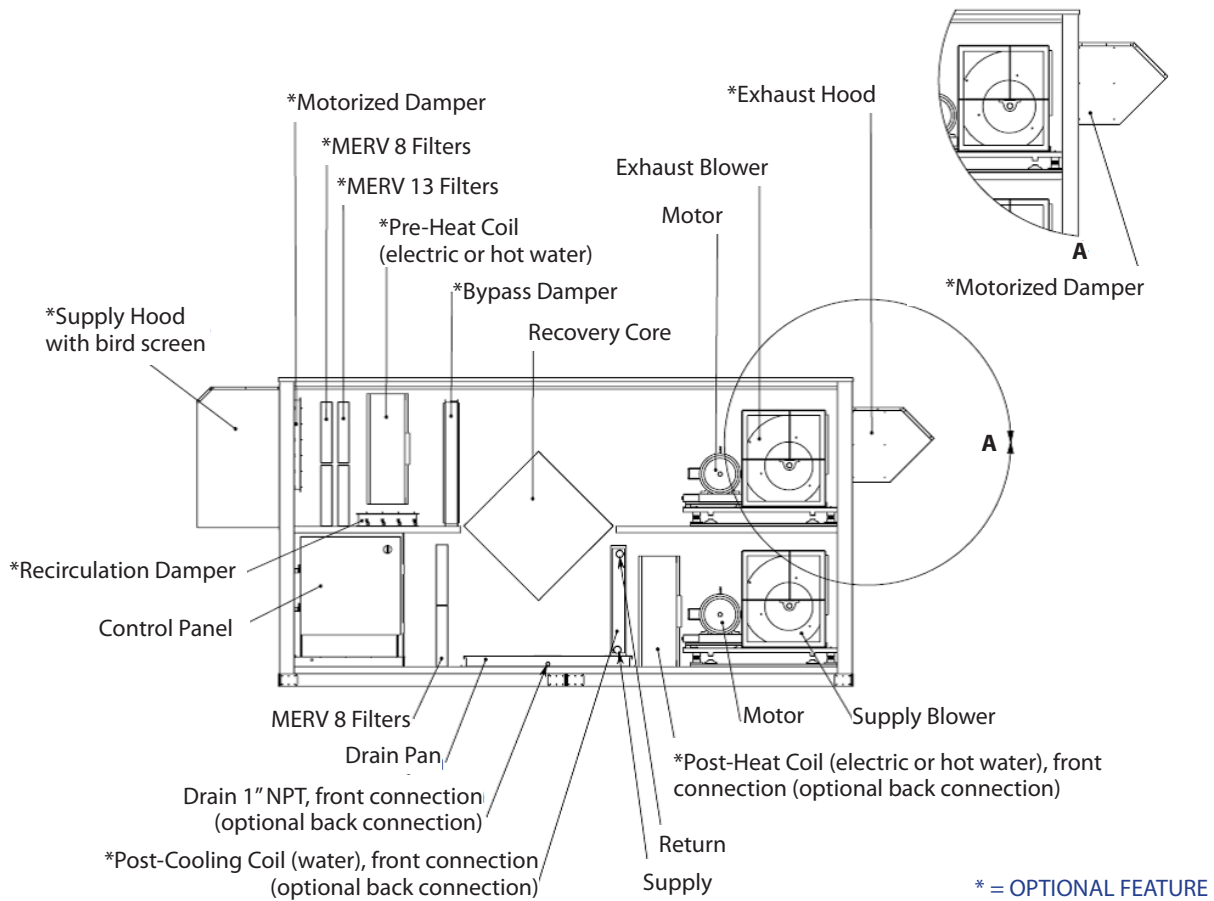

AVAILABLE CONFIGURATIONS
1-2-6-7
1-3-5-7
1-3-6-7
1-2-5-7

Mirror Image Cabinet Also Available

LEGEND	
RA	Return Air
SA	Supply Air
OA	Outside Air
EA	Exhaust Air

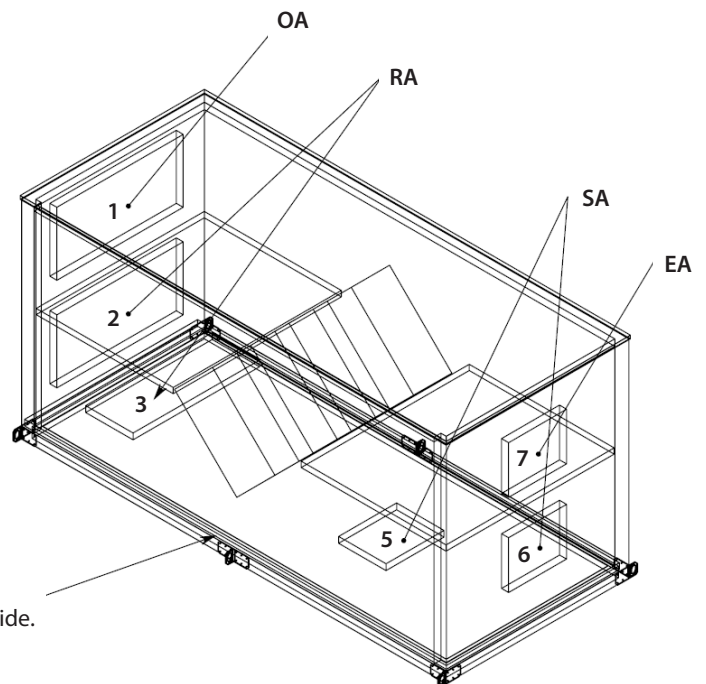

Access internal components on this side.

Dimensions & Weights

CABINET*																		
Unit	Height		Width				Length											V
	A	B	Overall		Overall - Standard				Overall - 1 Coil Option				Overall - 2 Coils Option					
			C		D	E		D	E		D	E						
	Overall	Base-Standard	Standard	Hoods Option	Base-Standard	Standard	Motorized Exhaust Damper Option	Hoods Option	Base-Standard	Standard	Motorized Exhaust Damper option	Hoods Option	Base-Standard	Standard	Motorized Exhaust Damper Option	Hoods Option	Front Clearance Required	
CE10000	95.8 (2502)	92.5 (2350)	98.5 (2502)	98.5 (2502)	141.3 (3589)	147.3 (3741)	151.8 (3856)	193.1 (4905)	161.3 (4097)	167.3 (4249)	171.8 (4364)	213.1 (4413)	181.3 (4605)	187.3 (4757)	191.8 (4872)	233.1 (5921)	87 (2210)	
CE10000BP**	95.8 (2502)	92.5 (2350)	98.5 (2502)	98.5 (2502)	141.3 (3589)	147.3 (3741)	151.8 (3856)	193.1 (4905)	161.3 (4097)	167.3 (4249)	171.8 (4364)	213.1 (4413)	181.3 (4605)	187.3 (4757)	191.8 (4872)	233.1 (5921)	87 (2210)	

OPENINGS															
Unit	F	G	H	I	J	K	L	M	N	O	P	Q	R	S	
CE10000	56 (1422)	28 (711)	56 (1422)	28 (711)	68 (1727)	18 (457)	N/A	N/A	24 (610)	22 (559)	24 (610)	22 (559)	24 (610)	22 (559)	
CE10000BP**	56 (1422)	28 (711)	56 (1422)	28 (711)	68 (1727)	18 (457)	N/A	N/A	24 (610)	22 (559)	24 (610)	22 (559)	24 (610)	22 (559)	

* All dimensions in inches (mm)

** Unit with bypass damper

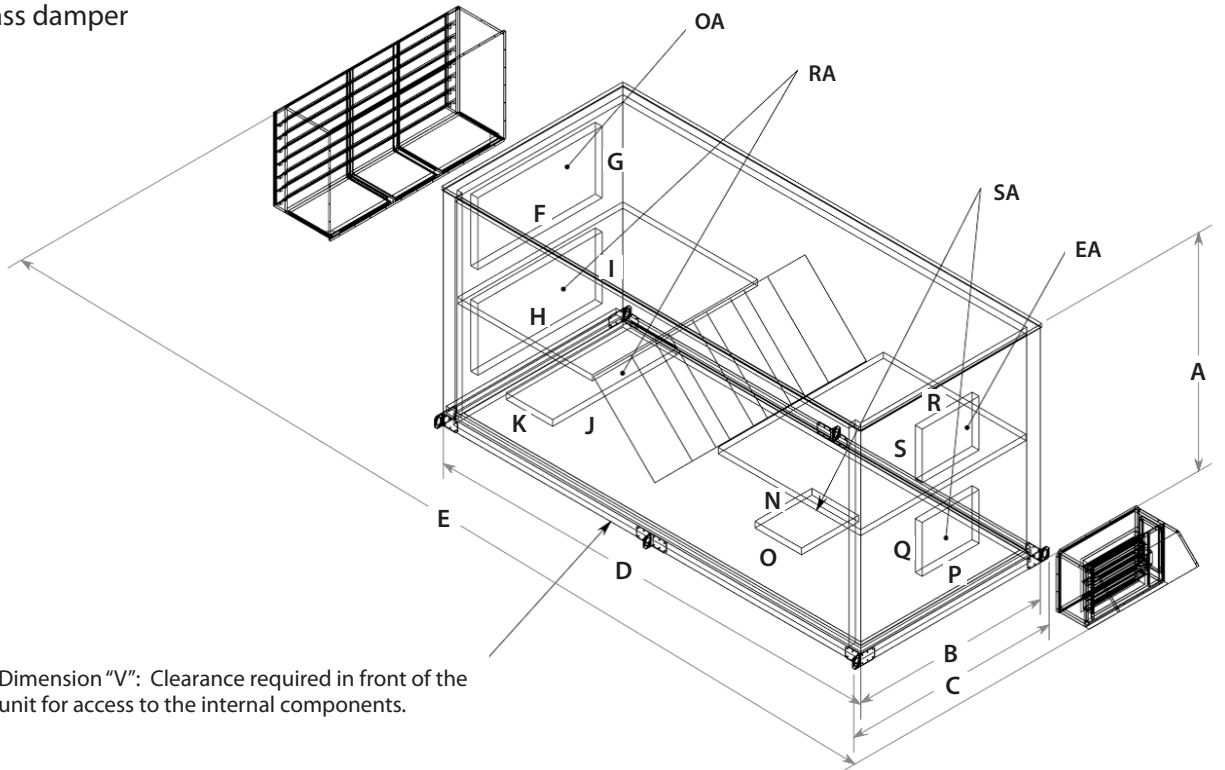

WEIGHT - CE10000†	
Minimum	4490 lbs (2037 kg)
Maximum	6431 lbs (2917 kg)

WEIGHT - CE10000BP†	
Minimum	5202 lbs (2360 kg)
Maximum	7024 lbs (3186 kg)

† Actual weight may vary by ±10%. Shipping weight calculated after final selection. Roof curbs shipped separately.

Roof Curb Dimensions

NOTE: Drawings not to scale

CE10000

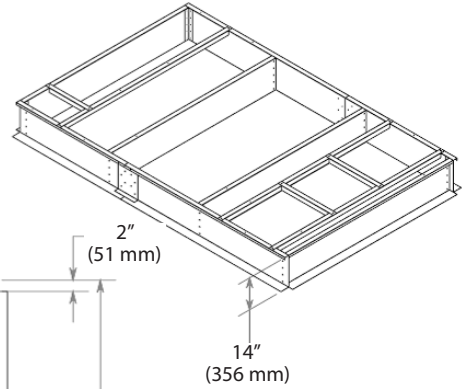
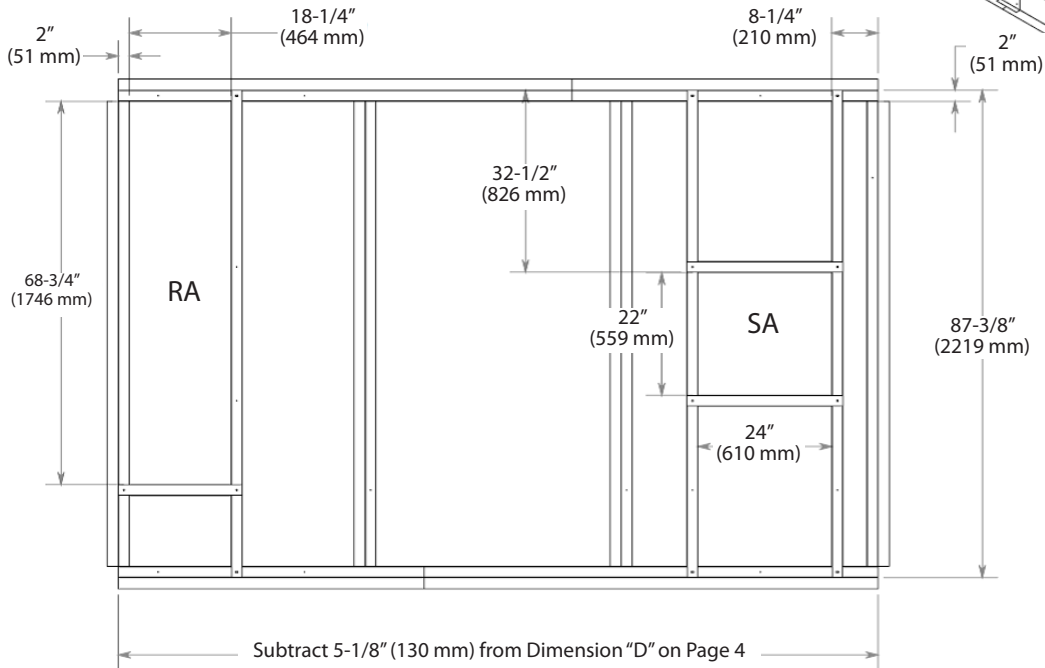

CE10000BP

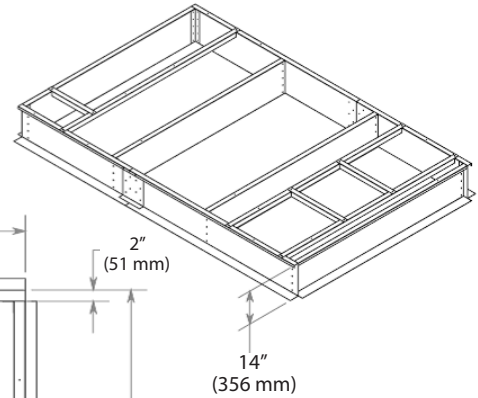
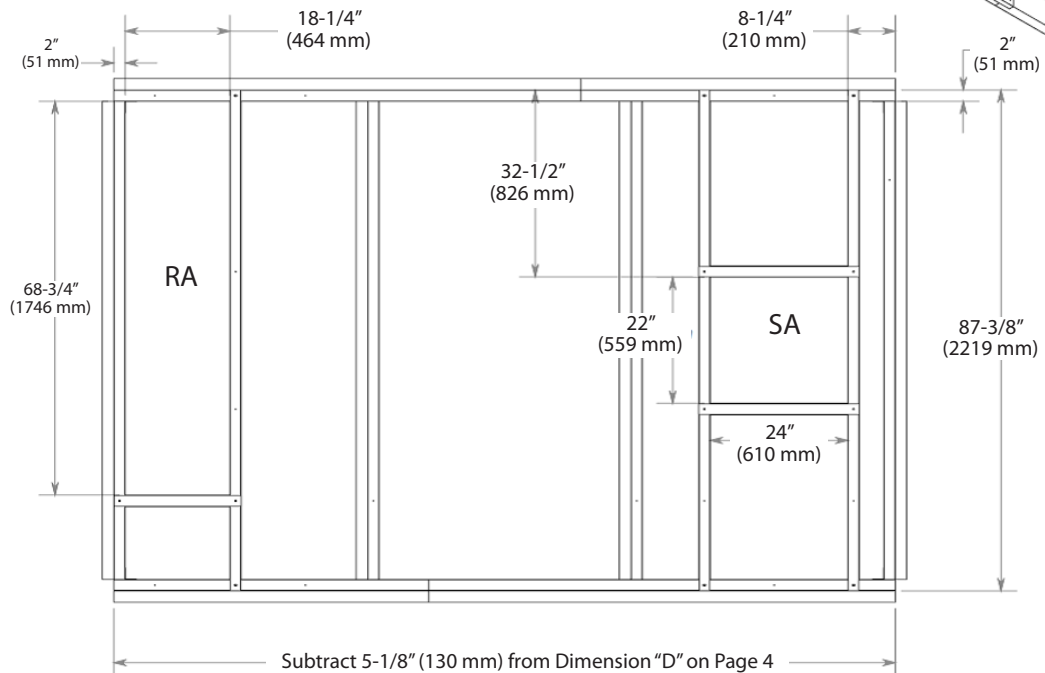

Roof Curb Assembly

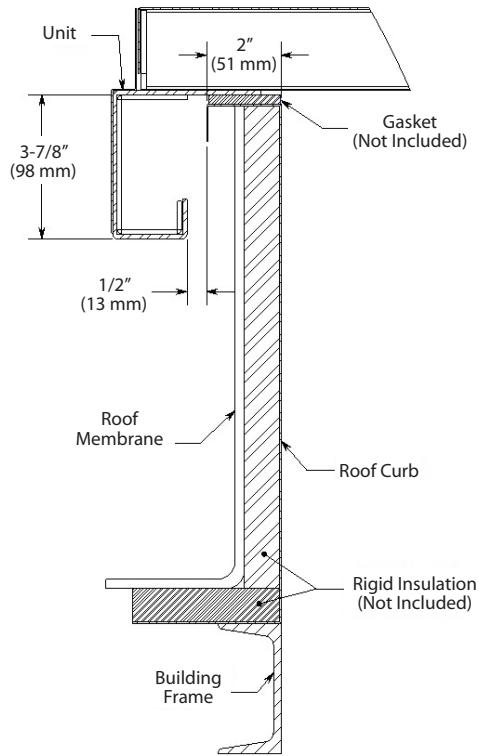

ROOF CURB WEIGHTS & DIMENSIONS	
Unit	CE10000
Roof Curb Weight	195 lbs (88 kg)
Shipping Weight	240 lbs (109 kg)
Shipping Dimensions (W x H x D)	96" x 28" x 25" (2438 mm x 711 mm x 635 mm)

ROOF CURB WEIGHTS & DIMENSIONS	
Unit	CE1000BP
Roof Curb Weight	220 lbs (100 kg)
Shipping Weight	265 lbs (120 kg)
Shipping Dimensions (W x H x D)	96" x 28" x 25" (2438 mm x 711 mm x 635 mm)

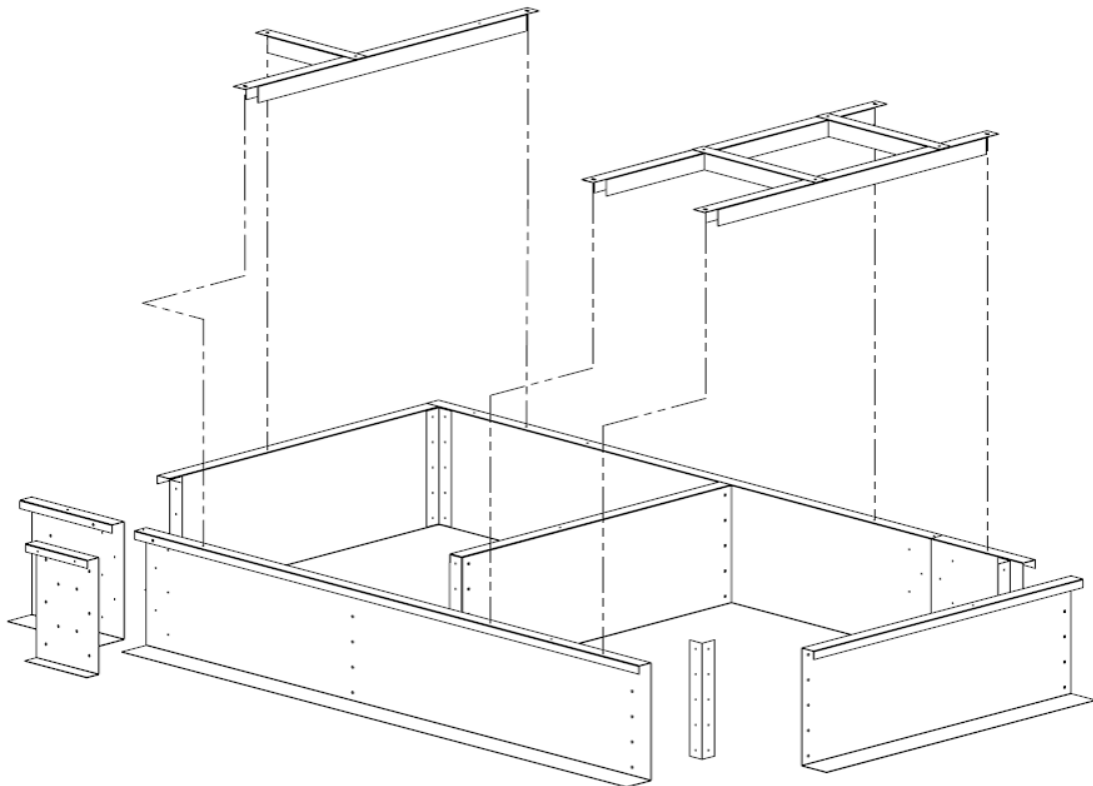

Enthalpy Core Performance

AHRI STANDARD CONDITIONS	CONDITIONS		AHRI STANDARD CONDITIONS	CONDITIONS	
Outside Temperature	Winter	Summer	Exhaust Air Temperature	Winter	Summer
Dry Bulb	35°F (1.7°C)	95°F (35°C)	Dry Bulb	70°F (21.1°C)	75°F (23.9°C)
Wet Bulb	33°F (0.6°C)	78°F (25.6°C)	Wet Bulb	58°F (14.4°C)	63°F (17.2°C)

Note: Efficiencies are based on AHRI standard winter conditions.

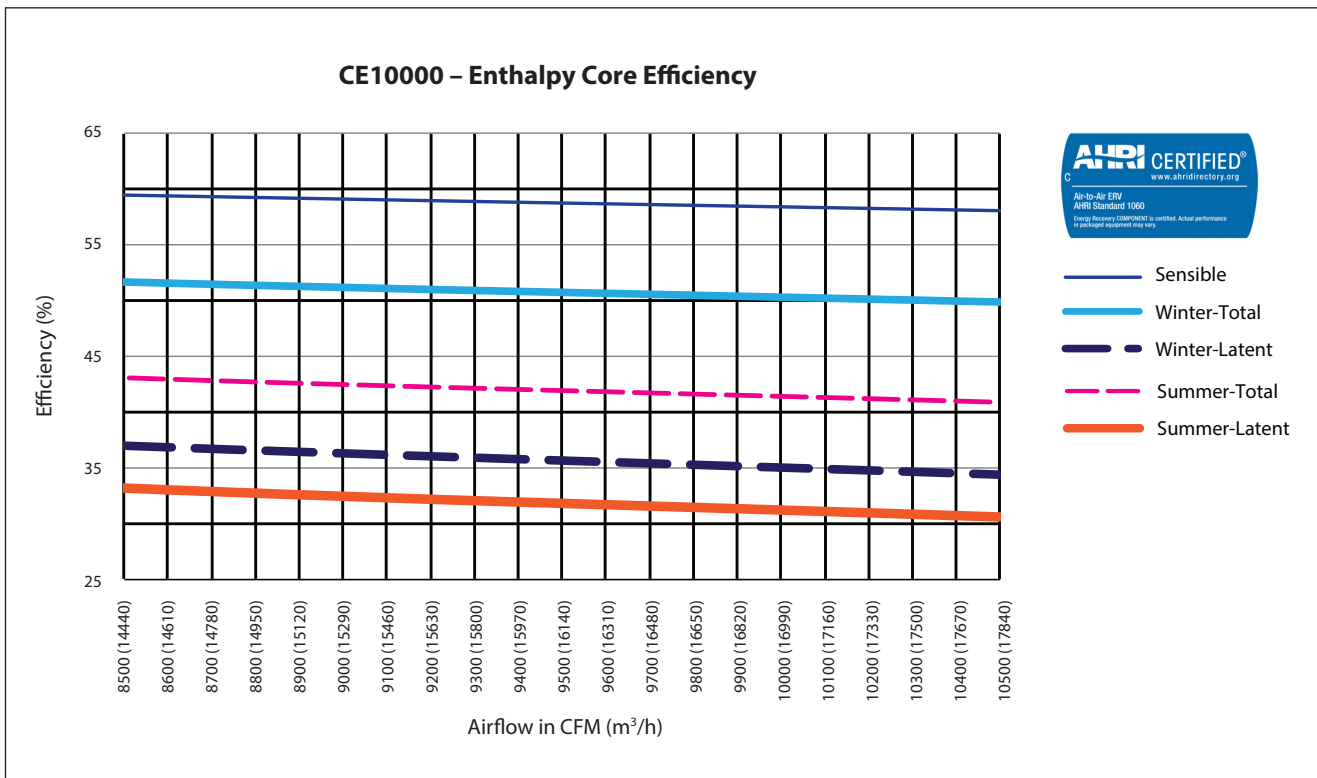

Motor Selection – Enthalpy Core

SUPPLY/EXHAUST																				
MOTOR	AIRFLOW	EXTERNAL STATIC PRESSURE (IN H ₂ O) - SUPPLY/EXHAUST																		MOTOR
		0.25 (60 Pa)			0.50 (125 Pa)			0.75 (185 Pa)			1.00 (250 Pa)			1.25 (310 Pa)			1.50 (375 Pa)			
		CFM (m ³ /h)	RPM	BHP	HP	RPM	BHP	HP	RPM	BHP	HP	RPM	BHP	HP	RPM	BHP	HP	RPM	BHP	
7.5 hp	8500 (14440)	843	5.60	6.72	885	6.00	7.20	925	6.42	7.70	965	6.85	8.22	1005	7.29	8.75	1045	7.76	9.31	10 hp
	8600 (14610)	850	5.77	6.92	891	6.17	7.41	931	6.59	7.91	971	7.03	8.43	1010	7.47	8.97	1040	7.94	9.53	
	8700 (14780)	856	5.94	7.13	897	6.35	7.62	937	6.77	8.12	976	7.21	8.65	1015	7.65	9.19	1054	8.13	9.75	
	8800 (14950)	863	6.12	7.34	904	6.53	7.84	943	6.95	8.34	982	7.39	8.87	1020	7.84	9.41	1059	8.32	9.98	
10 hp	8900 (15120)	870	6.30	7.56	910	6.71	8.05	948	7.14	8.56	987	7.58	9.09	1025	8.03	9.64	1063	8.51	10.21	15 hp
	9000 (15290)	876	6.48	7.78	916	6.90	8.28	954	7.32	8.79	993	7.77	9.32	1030	8.23	9.87	1068	8.71	10.45	
	9100 (15460)	883	6.67	8.00	922	7.09	8.51	960	7.52	9.02	998	7.96	9.56	1035	8.43	10.11	1073	8.91	10.69	
	9200 (15630)	890	6.86	8.23	929	7.28	8.74	966	7.71	9.25	1004	8.16	9.80	1041	8.63	10.35	1078	9.11	10.93	
	9300 (15800)	896	7.05	8.46	935	7.48	8.97	972	7.91	9.49	1010	8.36	10.04	1046	8.83	10.60	1082	9.32	11.18	
	9400 (15970)	903	7.25	8.70	941	7.68	9.22	978	8.12	9.74	1015	8.57	10.28	1051	9.04	10.85	1087	9.53	11.43	
	9500 (16140)	910	7.45	8.94	947	7.88	9.46	984	8.32	9.99	1021	8.78	10.54	1056	9.26	11.11	1092	9.74	11.69	
	9600 (16310)	916	7.65	9.18	954	8.09	9.71	990	8.53	10.24	1026	8.99	10.79	1062	9.47	11.37	1097	9.96	11.95	
	9700 (16480)	923	7.86	9.43	960	8.30	9.96	996	8.75	10.50	1032	9.21	11.05	1067	9.69	11.63	1102	10.18	12.22	
	9800 (16650)	929	8.07	9.68	966	8.51	10.22	1002	8.96	10.76	1038	9.43	11.32	1072	9.91	11.90	1107	10.41	12.49	
15 hp	9900 (16820)	936	8.28	9.94	972	8.73	10.48	1008	9.19	11.02	1043	9.66	11.59	1077	10.14	12.17	1112	10.64	12.76	
	10000 (16990)	942	8.50	10.20	979	8.95	10.74	1013	9.41	11.29	1049	9.88	11.86	1083	10.37	12.45	1117	10.87	13.04	
	10100 (17160)	949	8.72	10.47	985	9.18	11.01	1019	9.64	11.57	1055	10.12	12.14	1088	10.61	12.73	1122	11.11	13.33	
	10200 (17330)	956	8.95	10.74	991	9.41	11.29	1025	9.87	11.85	1060	10.35	12.42	1094	10.84	13.01	1127	11.35	13.62	
	10300 (17500)	962	9.17	11.01	997	9.64	11.56	1031	10.11	12.13	1066	10.59	12.71	1099	11.09	13.30	1133	11.59	13.91	
	10400 (17670)	969	9.41	11.29	1004	9.87	11.85	1037	10.35	12.42	1071	10.83	13.00	1105	11.33	13.60	1138	11.84	14.21	
10500 (17840)	975	9.64	11.57	1010	10.11	12.13	1043	10.59	12.71	1077	11.08	13.30	1110	11.58	13.90	1143	12.09	14.51		

NOTE:
HP = BHP x 1.2

Additional Air Pressure Drop with MERV 13 Filters

Airflow CFM (m ³ /h)	APD in. H ₂ O (Pa)
8500 (14440)	0.18 (44)
8600 (14610)	0.18 (45)
8700 (14780)	0.18 (46)
8800 (14950)	0.19 (46)
8900 (15120)	0.19 (47)
9000 (15290)	0.19 (48)
9100 (15460)	0.20 (49)
9200 (15630)	0.20 (49)
9300 (15800)	0.20 (50)
9400 (15970)	0.20 (51)

Airflow CFM (m ³ /h)	APD in. H ₂ O (Pa)
9500 (16140)	0.21 (52)
9600 (16310)	0.21 (53)
9700 (16480)	0.21 (53)
9800 (16650)	0.22 (54)
9900 (16820)	0.22 (55)
10000 (16990)	0.22 (56)
10100 (17160)	0.23 (56)
10200 (17330)	0.23 (57)
10300 (17500)	0.23 (58)
10400 (17670)	0.24 (59)
10500 (17840)	0.24 (59)

aldes ▲ = Standard Feature □ = Optional Feature (check the box to select this option) Send finished selection to Aldes Canada.

MODEL

Series: Advanced Commercial (CE) Nominal Capacity: 8500-10500 CFM Application: Interior (i) Exterior (e)

CASING

Cabinet Finish

- Painted
- Pool Construction

Supply & Exhaust Hoods

- Optional (exterior models)

Duct Configuration (see pg. 3)

- 1-2-6-7
- 1-3-5-7
- 1-3-6-7
- 1-2-5-7

Mirror Image Cabinet

- Optional

Roof Curb (exterior models)

- None
- Insulated
- Non-Insulated

Piping Connections

- Front
- Back

ELECTRICAL REQUIREMENTS

- 120V/1ph/60Hz
- 208V/1ph/60Hz
- 230V/1ph/60Hz
- 208V/3ph/60Hz
- 230V/3ph/60Hz
- 460V/3ph/60Hz
- 575V/3ph/60Hz

FILTERS

- MERV 8
- MERV 13 (Final Filter)

FROST CONTROL

- None
- Exhaust Defrost ¹
- Recirculation ¹
- Pre-Heat (Electric Coil)
- Pre-Heat (Hot Water Coil)
- Face & Bypass Damper

BLOWERS & MOTORS

Supply Blower

- 7.5 hp 15 hp
- 10 hp 20 hp

Exhaust Blower

- 7.5 hp 15 hp
- 10 hp 20 hp

Motor Type

- ODP, EPAAct ²
- ODP, Premium ³
- TEFC, EPAAct ²
- TEFC, Premium ⁴

Blower Type

- Forward Curved
- Backward Inclined

Blower Control

- Single Speed
- 2-Speed ⁵
- Programmable 2-Speed (VFD)
- VFD

HEATING OPTIONS

- None
- Post-Heat (Electric Coil)
- Post-Heat (Hot Water Coil)

COOLING OPTIONS

- None
- Cold Water Cooling Coil
- DX Cooling Coil

ADD-ONS

- Motorized & Insulated Damper for EA
- Non-Insulated Backdraft Damper for EA
- Motorized & Insulated Damper for OA¹
- Terminals for OA and/or EA damper power and control (24VAC, 10VA)
- Low Temperature Limit
- Economizer Cycle
- Dirty Filters Contact
- Low Airflow Switch
- Phase Loss Detection
- Damper End Switch
- Recirculation Dry Contact ⁶
- Programmable Timer
- CO₂ Sensor ⁷
- Relative Humidity Sensor ⁷
- BacNet Compatible Controller
 - With IP Module
 - With MS/TP Module
 - With Remote Keypad
 - With Remote Keypad (Touchscreen)
- Spare MERV 8 Filters QTY: _____
- Spare Belts QTY: _____

¹ OA Motorized & Insulated Damper included with exhaust defrost and recirculation
² EPAAct efficiency only available when Premium efficiency is not available (e.g., with single-phase motors)
³ ODP, Premium only available with ≥ 3 hp/ 3ph motors
⁴ TEFC, Premium only available with ≥ 1.5 hp/ 3ph motors
⁵ 2-Speed only available with ODP, EPAAct motors
⁶ Recirculation Dry Contact requires selection of recirculation defrost
⁷ Sequence of operations must be verified by factory

Project:		Architect:	
Location:		Engineer:	
Model #:		Contractor:	
Quantity:		Comments:	
Submitted By:			
Date:			

2015 ALDES Canada. Reproduction or distribution, in whole or in part, of this document, in any form or by any means, without the express written consent of ALDES Canada, is strictly prohibited. The information contained within this document is subject to change without prior written notice.