

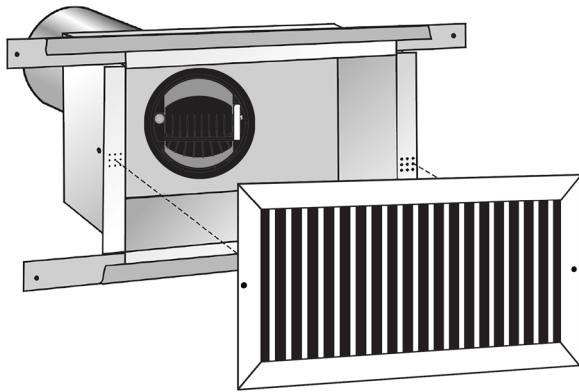

CSB3-WB

CONSTANT SUPPLY BOX

AIRFLOW & ZONE CONTROL



Grille not included.

Made in
USA

WARRANTY
7 YEARS

Patent
pending

Product Description

The Aldes CSB3-WB Constant Supply Box is a wall register box which incorporates an automatic, pressure independent balancing damper that regulates supply airflow in duct systems to constant levels. The passive control element (CAR3) in the CSB3-WB requires no electric or pneumatic power, sensors, and works solely off system pressure. Each CSB3-WB includes mounting brackets, and all necessary hardware for installation.

The CSB3-WB compensates for changes in duct pressure caused by stack effect, operable windows and doors, wind, loading filters, etc. The CSB3-WB provides a low-cost solution to maintaining the correct airflow balance of ventilation systems, improving system performance and indoor air quality, and provides significant savings on annual operating costs.

Key Features

- Dual-side airflow adjustment dial and CFM indicator allows you to set or change the airflow quickly.
- CAR3 is enhanced with antimicrobial, anti-static, and flame retardant additives for increased safety and durability.

APPLICATIONS

- Automatic balancing register box assembly for wall installation.
- Balance supply air in high-rise buildings.
- Ideal for hotels, multi-family, dorms, and assisted living facilities.

Construction

- CAR3 constructed of amorphous thermoplastic resin enhanced with antimicrobial, anti-static, and flame retardant additives to improve material performance, reduce need for maintenance, and increase safety.
- CAR3 is UL 2043 safety classified and labeled for flame and smoke generation (File No. R39897).
- Galvanized steel register box with steel duct collar.

Maintenance

The CSB3-WB needs no maintenance when used in normal conditions. The addition of antimicrobial and anti-static additives in the material increases the longevity and reliability of the CAR3. There is no risk of dust deposit or obstruction because the CAR3 has no airways subject to clogging. If the intended application includes air heavily loaded with dust or grease, access to the CAR3 is possible by removing the grille.

Warranty

Guaranteed for 7 years, from date of shipment, against all defects in material or workmanship, provided that the material has been installed and used under normal conditions. This warranty is limited to the repair or replacement of the material.

How to Specify Aldes: CSB3-WB

Step 1: Reference the model code below and performance details within this specifications sheet to select the appropriate CSB3-WB.

Step 2: Select the desired **AIRFLOW RANGE**.

NOTE: Ranges available: 4 or 5.

See *Airflow Settings and Performance Data* for additional details. Factory calibration of the CAR3 is available on request.

Step 3: Select the **DUCT COLLAR DIAMETER**.

NOTE: This number cannot be less than the **AIRFLOW RANGE**; i.e. an airflow range of 5 requires a duct size of 5”.

Step 4: Select the **NOMINAL GRILLE WIDTH** and **NOMINAL GRILLE HEIGHT**.

NOTE: Nominal width or height must be greater than the duct size; 4, or 5 selected in **DUCT COLLAR DIAMETER**.

See dimensions for additional details.

Model Code Example

CSB3-L4-WB-4-0606

PARENT MODEL

Constant Supply Box

PRESSURE RANGE

L: Low-Pressure (0.12-1.2 in. w.g.)

AIRFLOW RANGE

Low-Pressure

4: 15-85 CFM (25-144 m³/h)

5: 35-180 CFM (59-306 m³/h)

APPLICATION

W: Wall

COLLAR LOCATION

B: Back

COLLAR DIAMETER

4 inch

5 inch

NOMINAL GRILLE WIDTH

NOMINAL GRILLE HEIGHT

CSB3-WB Dimensions

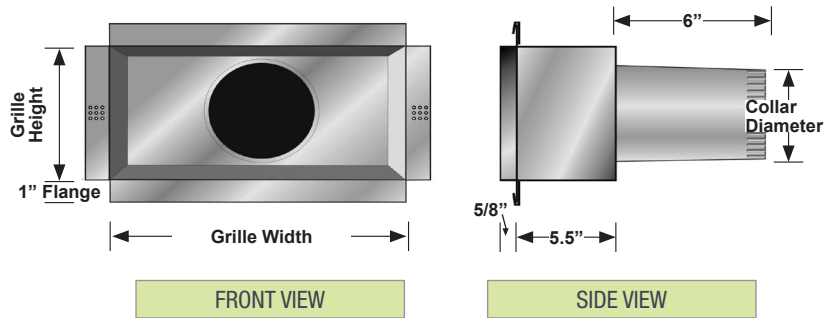

GRILLE SIZES		
	Nominal Width*	
	6	8
Nominal Height*	4	
	6	
	8	

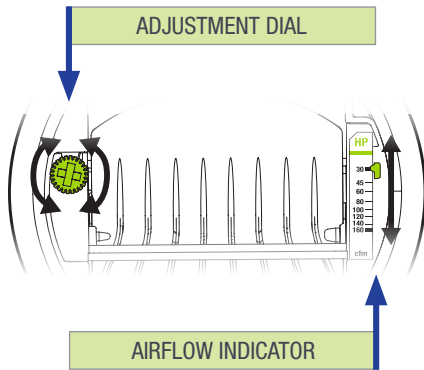

Airflow Settings & Performance Data

Airflow rate can be set or adjusted by rotating the dial from either side. The airflow indicator will move to show the selected CFM. The airflow label has multiple defined setpoints, but the unique adjustment mechanism of the CSB3-WB allows for infinite adjustability between the minimum and maximum limits.

Performance charts found in the specifications sheet reflect this data, with the available range (shaded) and marked setpoints (lines). The CSB3-WB will maintain the airflow accurately to within +/- 10% of the indicated lines below for each marked setpoint. At the higher airflow rates, the minimum pressure required to achieve the selected airflow may exceed 0.12 in. w.g.

CAR3 4" DIAMETER (100 mm)

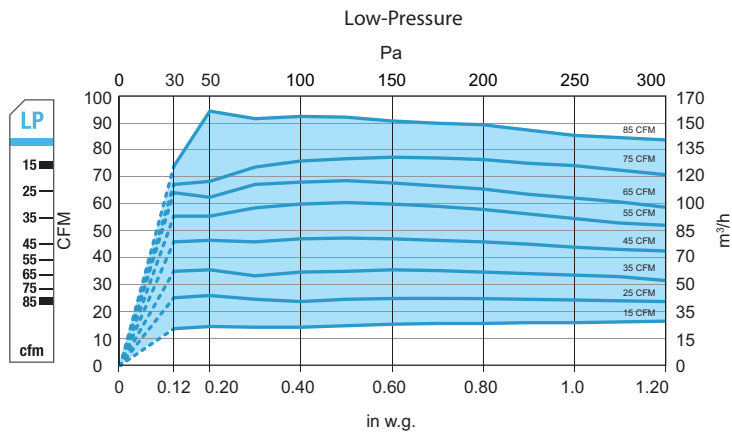

CAR3 5" DIAMETER (125 mm)

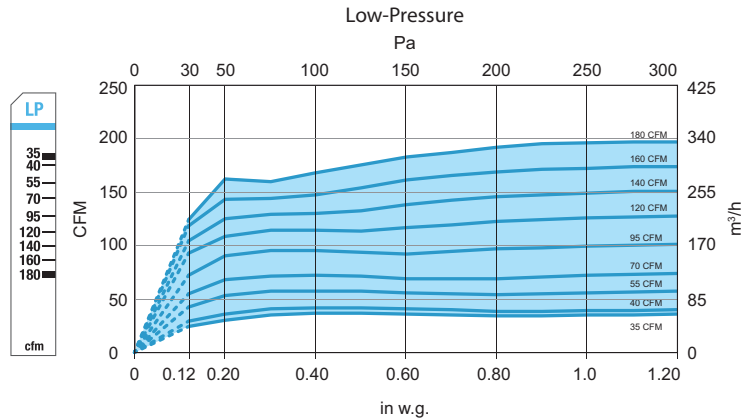



Recommended Specification

Model CSB3-WB Constant Supply Box by ALDES North America shall be of sizes and capacities as scheduled, and located per the drawings. The plenum box casing shall be minimum 24-gauge G90 galvanized steel with an integral steel duct collar that allows attachment of both rigid and flexible ducting. The collar shall be sized to allow full insertion of a model CAR3 Constant Airflow Regulator for airflow control, but without the regulator extending into attaching duct. Each assembly will be capable of maintaining constant airflow within +/-10% of the scheduled flow rate, within the operating range of 0.12 to 1.2 in. w.g. differential pressure for low-pressure model (CAR3-L). CSB3-WB solely operate on duct pressure and require no external power supply or sensor, and shall be rated for use in air temperatures ranging from -25°F to 140°F (-32°C to 60°C). Each airflow regulator shall feature dual-side adjustment dial to allow changes in airflow setpoint while installed in either the supply or exhaust direction without removing the regulator from the assembly. Each CAR3 must be calibrated to match the airflow indicated on the schedule or drawing. Regulator must be classified per UL 2043 and carry the UL mark indicating compliance. Constant Airflow Regulator is enhanced with antimicrobial, anti-static, and flame retardant additives for increased durability and safety, and covered under warranty for a period of no less than seven years. Each CSB3-WB shall include all necessary mounting brackets and hardware. Constant Supply Box shall be installed in accordance with local code and manufacturer's instructions.

For more information, contact your Aldes sales advisor, visit aldes-na.com, call 1.800.255.7749, or find us on

