



VENTERGY® IAQ-MPVS

MULTI-PORT CONTINUOUS EXHAUST ACCESSORY KIT

RESIDENTIAL SYSTEM SOLUTIONS

Product Description

ALDES North America Ventergy® Series IAQ-MPVS Multi-Port Ventilator Kits recommends an optional MPVS120 ventilators (sold separately) to provide optimal, continuous exhaust ventilation. Every kit includes integral Constant Airflow Regulators (CAR Classic) for precise airflow regulation, deco grilles and universal sleeves. The products are engineered to work seamlessly together for installation ease and guaranteed performance. IAQ-MPVS Kits can be used in homes with 2-4 bathrooms. Expansion Kits are available.

Number of Bathrooms	Number of Collars	3" CAR Classic (25 CFM)	3" Deco Grille	3" Universal Sleeve with "L" Bracket	RECOMMENDED FAN Sold separately Ventilator
					
2	2	2	2	2	MPVS120
3	3	3	3	3	MPVS120
4	4	4	4	4	MPVS120

For more information, contact your Aldes sales advisor, visit aldes-na.com, call 1.800.255.7749, or find us on





3" CAR CLASSIC

CONSTANT AIRFLOW REGULATOR

AIRFLOW & ZONE CONTROL

WARRANTY
5 YEARS

Product Description

The model CAR 3" Constant Airflow Regulator is a modulating orifice that automatically regulates airflows in duct systems to constant levels. The passive control element responds to duct pressure and requires no electric or pneumatic sensors or controls.

The CAR compensates for changes in duct pressure caused by thermal stack effect, building pressure, dust-clogged filters, etc. The CAR also provides a low-cost solution to balancing forced-air systems for heating, air conditioning and ventilation, eliminating the need for on-site balancing. The CAR will regulate airflow in supply, return, or exhaust duct systems.

The active control element of the CAR is a flexible bulb that inflates and deflates in response to the static pressure difference across the control. This operation regulates the free-area opening through the control, resulting in maintenance of velocity and specific airflow set points. Each CAR is designed and produced for control of air in temperatures ranging from -25° to 140°F (-32° to 60°C).

Performance

The CAR controls airflow accurately to within 15% of rated flow throughout the target operating pressure range of 0.2 to 0.8 in. w.g. (50 to 200 Pa). Each CAR is factory tested and calibrated to the rated set point before shipping. On-site field adjustment of airflow set points can be made for supply air applications (contact factory). The CAR is available in four factory-calibrated set points (see performance curves).

Maintenance

The CAR needs no maintenance when used in normal conditions. There is no risk of dust deposits or obstruction because the CAR has no airways subject to clogging. If the intended application includes air heavily loaded with grease or dust, a fitting with an access panel or door, such as that used for flame dampers, should be provided.

Construction

The CAR regulating element is housed in a heavy-gauge rolled galvanized steel sleeve. Each sleeve is seam welded to prevent leakage. The assembly is sized to fit inside standard rigid round ducting, as well as fittings such as take-offs and tees. A brush or flex-type ring seal gasket around the circumference ensures a tight, no-leak fit. Spring-action metal clips on the housing grip the interior of the duct or fitting to secure the control firmly in place with minimal installation effort.

Warranty

Guaranteed for five (5) years, from date of shipment, against all defects in material or workmanship, provided that the material has been installed and used under normal conditions. This warranty is limited to the repair or replacement of the material.

APPLICATIONS

- Supply and exhaust air for offices
- Balancing exhaust and supply airflows in high-rise building duct risers
- Bathroom exhaust in nursing homes, hotels, motels, dormitories, apartments, offices, etc
- Clean room air supply balancing for ceiling filter modules. Maintains constant airflow, even as filter resistance increases
- Regulation of make-up air
- Balancing supply airflow from packaged roof-top A/C units
- Balancing supply and exhaust of heat recovery ventilation systems
- Regulating outdoor air injection from central supply fan into individual room fan coil units or heat pumps
- Balancing airflows on series-fan-powered terminal unit systems
- Supply air to sleeping quarters in military facilities, submarines, etc

How the CAR Classic Works

Constant airflow is achieved by the inflating action of the CAR's bulb. At minimum static air pressure, the bulb is deflated and has a shape similar to an hourglass. As the static pressure increases across the bulb, it inflates, thereby reducing the free area around the bulb. At the same time, the higher static pressure increases the air velocity, resulting in CONSTANT AIRFLOW. This occurs regardless of pressure differences in the range of 0.2 to 0.8 in. w.g. (50 to 200 Pa). The air velocity in the duct is in the range of 60 to 700 ft/min. (0.3 to 3.5 m/s).

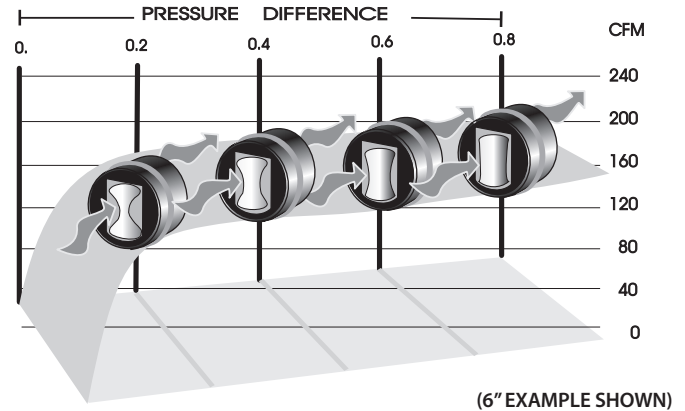

Performance Data

Performance charts reflect airflow measurements taken at 68°F (20°C) at 1 atmosphere pressure. Airflows are rounded to the nearest 5 CFM or 5 m³/h. Sizes are nominal. Product is designed to be inserted into duct of indicated diameter. Airflows are factory pre-set and cannot be modified by installer. When ordering, specify the part number (p/n), diameter, and airflow.

3" DIAMETER (80 MM) REGULATING ELEMENT

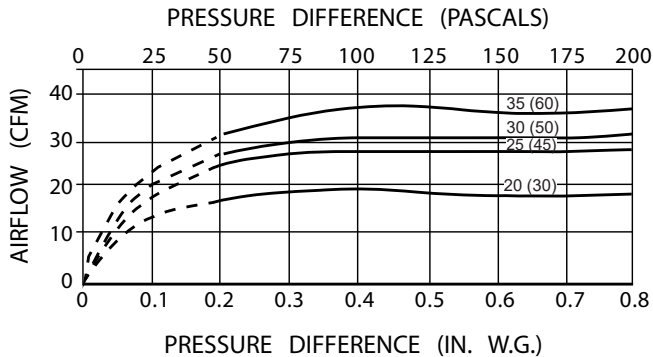

3" CAR Classic Dimensions

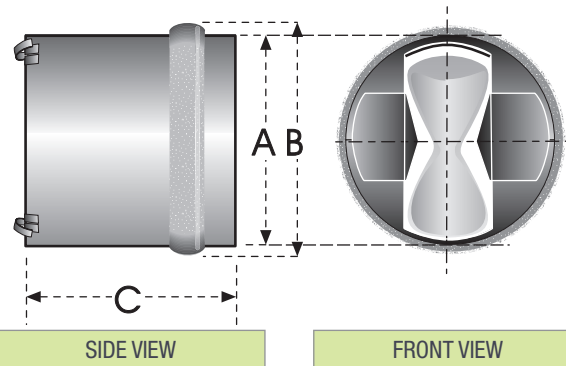

DUCT	CAR Classic	A	B	C
3"	3"	2-7/8"	3-1/4"	3-1/4"

PART NUMBER	AIRFLOW	PART NUMBER	AIRFLOW
16 421	20 CFM (30 m ³ /h)	16 424	30 CFM (50 m ³ /h)
16 422	25 CFM (45 m ³ /h)	16 423	35 CFM (60 m ³ /h)

Recommended Specification

Model CAR Constant Airflow Regulators by ALDES North America, shall solely operate on duct pressure and require no external power supply. Each regulator shall be pre-set and factory calibrated, requiring no field adjustment to the airflows as indicated on the schedule. Rated for use in air temperatures ranging from -25° to 140°F (-32° to 60°C).

Constant Airflow Regulators shall be capable of maintaining constant airflow within +/- 15% of scheduled flow rates within the operating range of 0.2 to 0.8 in. w.g. differential pressure. Sound power levels shall not exceed those for each size and CFM rating as scheduled. Regulators shall be provided as an assembly consisting of a flame-resistant plastic body. All Constant Airflow Regulators will require no maintenance and must be warranted for a period of five (5) years. Constant Airflow Regulators shall be installed in tight ducting systems in accordance with all applicable codes and manufacturer's instructions.

For more information, contact your Aldes sales advisor, visit aldes-na.com, call 1.800.255.7749, or find us on





DECO GRILLES

WHITE PLASTIC GRILLES

ROOF CAPS, WALL HOODS, GRILLES
& DUCT FITTINGS

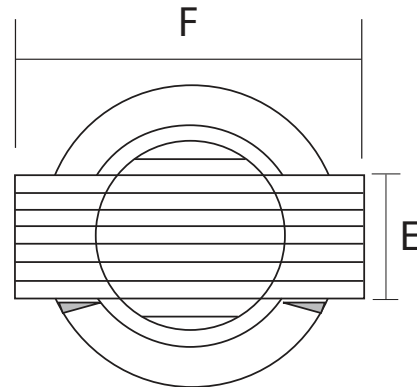
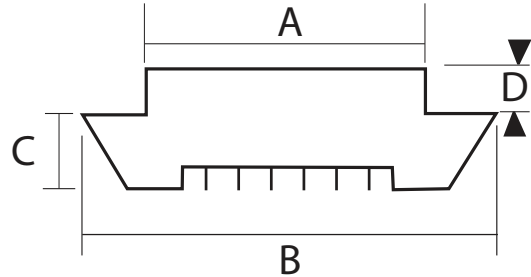

Dimensional Data

PART NUMBER	SIZE	DESCRIPTION	A	B	C	D	E	F
22 073	3"	White Plastic ABS Grille	3"	4-3/4"	1/2"	5/8"	1-7/8"	4-3/4"
22 079	4"	White Plastic ABS Grille	3-7/8"	5-3/4"	11/16"	1"	2-1/2"	6-1/4"
22 078	5"	White Plastic ABS Grille	4-7/8"	6-1/2"	5/8"	1-1/4"	3-1/8"	7-3/4"

For more information, contact your Aldes sales advisor, visit aldes-na.com, call 1.800.255.7749, or find us on





MOUNTING SLEEVE

WITH CEILING-MOUNT BRACKET

ROOF CAPS, WALL HOODS, GRILLES
& DUCT FITTINGS

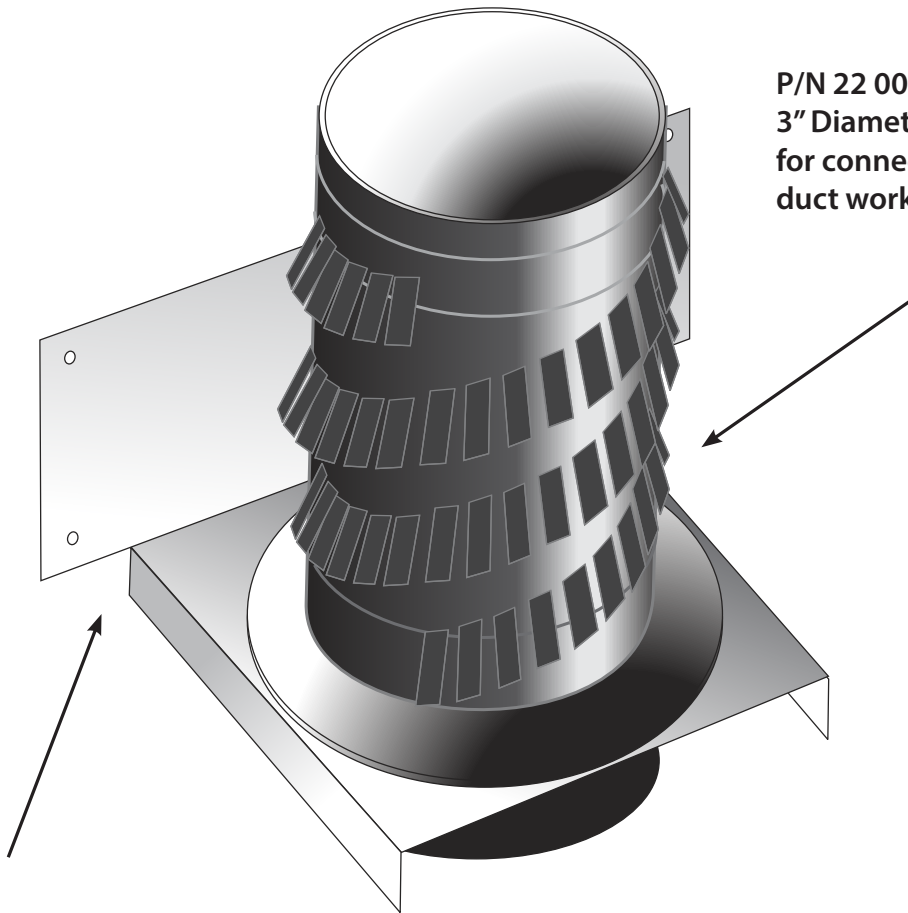

P/N 22 001:
3" Diameter Mounting Sleeve
for connecting grille to flexible
duct work

P/N 54 020:
3" Ceiling-Mount Bracket
enables ceiling rough-in when
used with mounting sleeve

For more information, contact your Aldes sales advisor, visit aldes-na.com, call 1.800.255.7749, or find us on





MPVS100 & MPVS120

MULTI-PORT EXHAUST VENTILATORS

VENTERGY® SERIES FANS



*MPVS100 only

Product Description

Ventergy® Series Multi-Port Ventilators (MPVS) are highly versatile, continuous-duty rated fan units for residential and light commercial applications. The MPVS100 meets ENERGY STAR efficiency criteria for low-energy consumption. The most popular use is central, continuous exhaust ventilation of bathrooms, kitchens, laundry rooms, and other rooms where humidity is a controlling factor since the fan has a single exhaust discharge duct directly to the outdoors.

The principal advantage of the MPVS is the assurance of controlled indoor air quality ventilation and the elimination of standard noisy bath fans, with the benefits of reduced noise and fewer penetrations to the exterior of the building. With the increasingly tight construction of energy-efficient buildings, there is a growing need for mechanical ventilation for indoor air quality. These fans are designed to serve this purpose by providing effective bathroom ventilation with the ability to run intermittently or continuously. The quiet, energy-efficient, permanent-split-capacitor type of external-rotor motor has permanently sealed bearings that provide many years of maintenance-free performance.

Construction

The MPVS is constructed of heavy-gauge galvanized steel to prevent corrosion caused by moisture. The cabinet is internally lined with acoustic, closed-cell foam insulation that acts as a vapor barrier. This allows installation directly above living spaces or in unheated plenum spaces without concern for noise or condensation.

Controls

The fans can be operated manually or automatically by a programmable timer or dehumidistat. They may also be operated in conjunction with a variable speed control.

Fan and Motor

The fan motor is an energy-efficient, permanent-split-capacitor type of external-rotor design. Totally sealed to protect against moisture and contaminants, it is approved for removing steam and moisture from kitchen and bath areas. The motor incorporates permanently lubricated and sealed bearings and automatic-reset thermal-overload protection. It is designed and certified for continuous duty or intermittent operation.

The fan uses a backward-inclined impeller design that prevents dust from collecting on the blades. Each fan is statically and dynamically balanced in the factory to eliminate vibration and ensure quiet operation. The entire motor and fan assembly is mounted on a drop-down hinged access panel for simple service and inspection, and it can be removed from the fan without disassembling the duct connections.

Locating and Installing

The compact dimensions and versatile mounting options permit installation above drop ceilings, between ceiling joists, or within a small soffit location. They can be installed horizontally or vertically.

Accessories

Accessory kits are available to facilitate installation and enhance operation. Accessories kits are sold separately. Please visit aldes-na.com, or contact your local Aldes distributor for details.

Performance

Fan airflow and energy performance shall be tested in accordance with HVI procedures.



*MPVS100 only

Dimensions & Performance

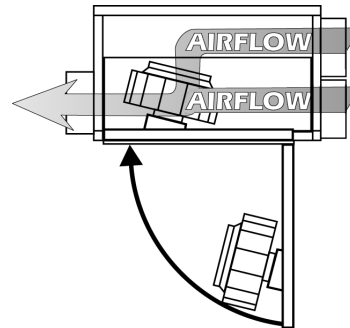
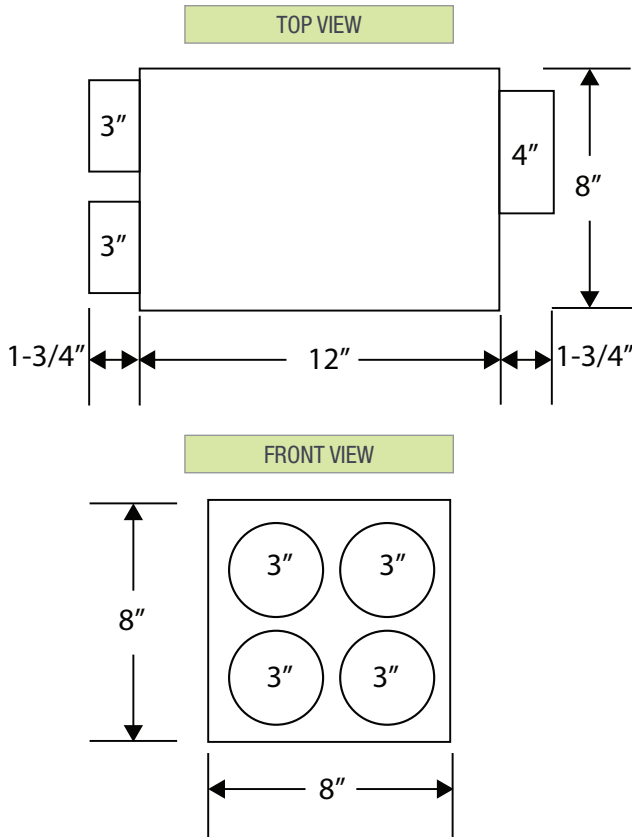

ELECTRICAL AND AIRFLOW PERFORMANCE*

Model	Watts at 0.2" Ps	CFM vs. Static Pressure						ENERGY STAR Certified
		0.0"	0.2"	0.4"	0.6"	0.8"	1.0"	
MPVS100	20.8	108	88	68	48	25	--	√
MPVS120	37.5	143	128	111	95	74	45	

*Certified airflow rating at 0.2" w.g. is derated from actual test results per HVI Certification procedure 920. The HVI Certified Rate for MPVS100 = 80 CFM, MPVS120 = 120 CFM.

ELECTRICAL DATA

MPVS100: 115 V, 60 Hz, 21 W, 0.19 A, 2500 RPM
 MPVS120: 115 V, 60 Hz, 34 W, 0.29 A, 3135 RPM

Above ratings are intended for sizing electrical wiring only. Actual consumption will be lower.

Recommended Specification

GENERAL The fan shall be continuous-duty type with a backward-inclined centrifugal blower housed in a multi-port enclosure specifically designed for residential and commercial use. The fan shall be safety tested per UL standards and bear the agency listing certified mark, and be approved for use over cooking areas and tub/shower enclosures when used with GFCI branch circuiting.

CONSTRUCTED The housing shall be of a minimum 22-gauge steel with a G90 galvanized coating or baked enamel paint finish. All interior surfaces of the housing shall be lined with non-porous, closed-cell foam insulation to allow installation above ceilings and in unheated spaces without concern for condensation or absorption of water. The unit shall not exceed 8" in total height and 8" in width to allow mounting within ceiling/floor joist spaces. The blower shall be a centrifugal-type, external-rotor motor with backward-inclined impeller blades. The motor and blower assembly shall be mounted on a drop-down hinged access panel so as to permit removal from the housing without disassembly of the ducting connections. The intake duct connections shall be dimensioned so as to accept constant airflow regulators with a secure fit. The intake duct dimensions shall be nominal 3" round. The discharge duct dimension shall be nominal 4" round. The fan housing and intake duct collar(s) shall be designed to allow removal and repositioning in the field to accommodate different installation requirements. Mounting brackets shall be provided for attachment to the fan housing, allowing vertical or horizontal installations.

MOTOR The motor shall be direct-drive, external-rotor, high-efficiency, PSC type with permanently lubricated and sealed ball bearings. The motor shall have automatic thermal-overload protection and must be totally sealed to protect against contaminants and moisture. Naturally vented air-over motors are not acceptable.

ELECTRICAL: The fan will operate on 115V, 50/60Hz, and single-phase current. The motor will be listed for use with a solid-state speed control.

3 YEAR WARRANTY for entire unit, from date of shipment, against all manufacturing defects, provided the material has been installed and operated per manufacturer's instructions and under normal conditions. Warranty is limited to the repair or replacement of the material upon its return freight paid to our factory. This warranty is not transferable and is limited to the original end user.

For more information, contact your Aldes sales advisor, visit aldes-na.com, call 1.800.255.7749, or find us on

