

NEW

InspirAIR® Commercial Heat and Energy Recovery 500-4000 CFM



#HealthyLiving



For more than 30 years, Aldes North America has resolved challenging indoor air quality issues by taking a “systems approach” to ventilation. Aldes North America products are designed for superior airflow control, energy-efficient performance, and a healthy indoor environment.

Aldes North America has specialty ventilation products for single-family homes all the way to towering commercial buildings. Builders seeking LEED project credits or designers working within challenging constraints will find Aldes North America products are cost effective and suited to their ventilation and indoor air quality needs.

What do you consider when selecting a Heat or Energy Recovery Ventilator? Aldes knows that HRV/ERV decisions are never taken lightly. That’s why we manufacture our Commercial HRV/ERV with the features you need, the performance you expect, and the superior build quality you deserve. We offer all available types of air-to-air heat exchangers in a variety of price points and configurations. Every job is custom built to your exact design parameters. We want you to be confident in your choice - from the moment you make the selection to years after installation. Every Aldes product is equal parts innovation and experience. Your business is our pleasure. Your satisfaction is our priority.

Selection Simplicity with Aldes Selector™ Software

Selector™ puts you in the designer’s seat and ensures a better finished product.

- Select models based on your exact design conditions and parameters
- Compare units for the best fit and performance
- Receive detailed submittals for your unit
- Generate project schedules to indicate critical performance data
- Share designs and import projects directly into the software
- Streamline your workflow

Selector™ is available by request. Contact techsupport-us@aldes.com



Why Choose InspirAIR® Commercial

The NEW Commercial HRV/ERV solution that offers the highest efficiencies and richest set of easy to-configure options.

Our newest line of Commercial Heat and Energy Recovery Ventilators is now available! Great value and tons of options, all in robust, standardized cabinet sizes. For indoor and rooftop applications from 500 to 4000 cfm. Choose among three types of fixed plate heat and energy recovery cores or an enthalpy wheel for maximum efficiency. Add heating coils, EC motors and an advanced BacNET controller to get the most out of your investment.

The InspirAIR® Commercial also offers an optional internal bypass channel and damper for economizer operation, with no need to connect any additional ductwork or components to the outside of the units.

InspirAIR® Commercial was designed for the needs of the construction industry: it's budget-conscious yet offers a wide range of options to fit into most types of buildings and design conditions. And with Aldes North America excellent service and delivery times, you can't go wrong choosing InspirAIR® Commercial!

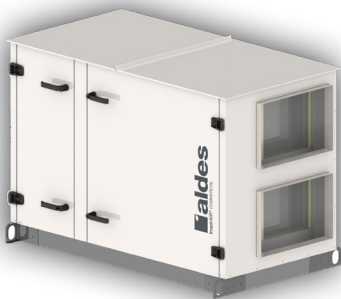

PH 15

* Mirror image cabinet also available

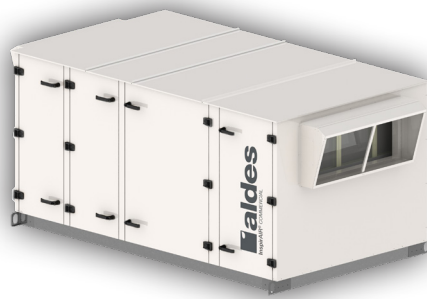

PH 30

(Model shown with hood option)

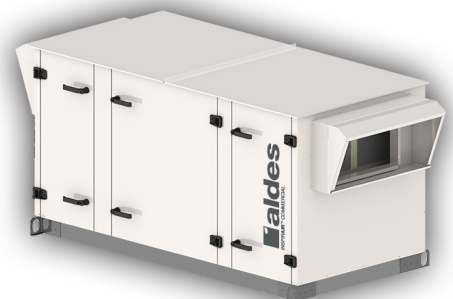

PW 40

(Model shown with hood option)

Key Features

- Up to 75% plate total efficiency
- Up to 85% wheel total efficiency
- Indoor & Outdoor Applications
- Digital Controls (BACnet Ready)
- Double Wall Construction (Standard)
- Frost Control
- Post-Heating Options
- MERV 8 Filter
- Free Cooling Management (Add-on)
- Programmable Timer (Add-on)

PE | High Latent Transfer *Sensible and latent heat transfer*



The High Latent Transfer heat exchanger is a proprietary technology developed by Aldes to suit the needs of all North American climate types and zones. Not only does this core technology meet or exceed all performance expectations, but it is designed to withstand the rigors of use more so than any comparable core technology.

PW | Desiccant Wheel *Sensible and latent heat transfer*

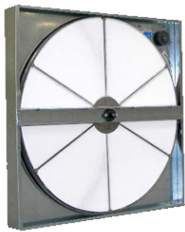

The high latent and sensible exchange, is excellent for humidity control and significantly lowers cooling loads in high RH environments. It easily manipulates recovery efficiencies by varying wheel rotation rate without changing airflow rates, it allows for lower operating temperatures than other technologies.

PA | Aluminum *Sensible heat transfer*



The Sensible heat transfer exchanger is excellent for winter dehumidification. Designed with rugged, heavy-duty construction, it's easy to maintain and clean. Providing no cross contamination.

PH | Polypropylene *Sensible heat transfer*

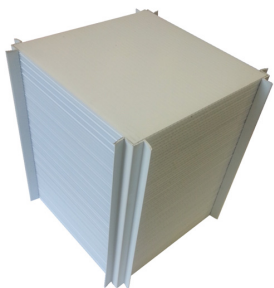

The Sensible heat transfer exchanger is excellent for corrosive environments (indoor pools, water treatment plants, etc). Designed with rugged, heavy-duty construction, it's easy to maintain and clean. Providing no cross contamination.

Reading the MODEL CODE

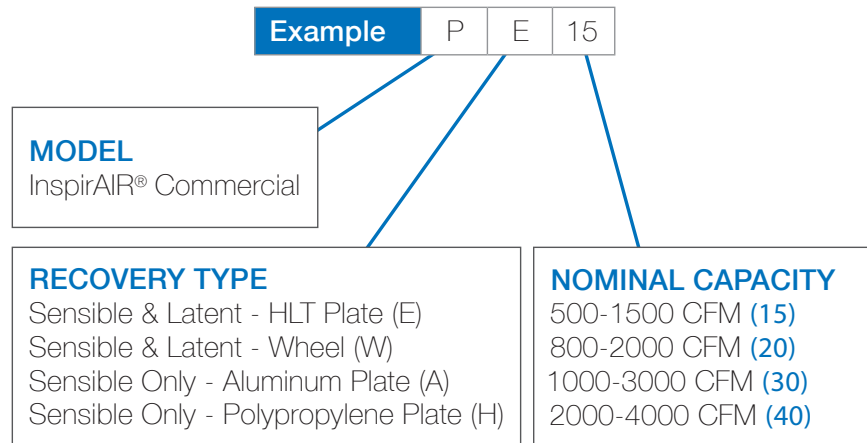

MODELS			
PA15	PA20	PA30	PA40
PE15	PE20	PE30	PE40
PH15	PH20	PH30	PH40
PW15	PW20	PW30	PW40

Airflow Range by Models

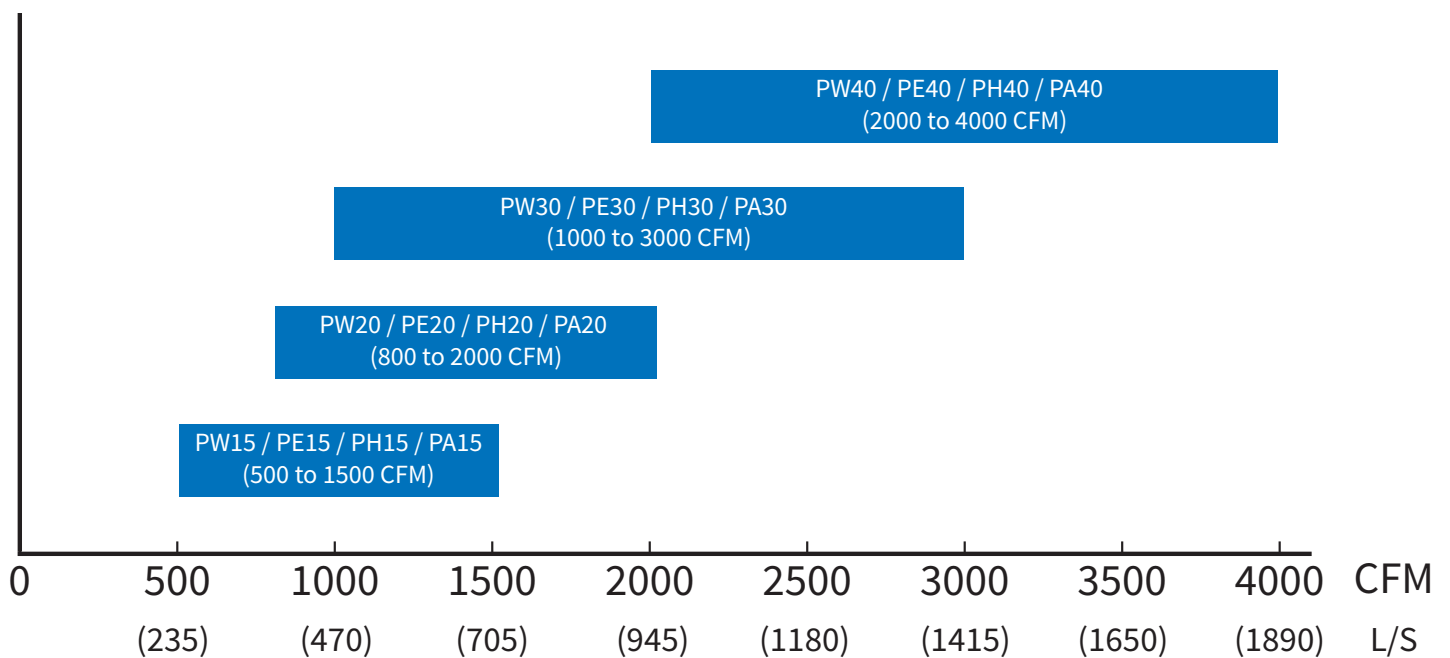

Free Cooling (with Bypass or Wheel)

Automatic free cooling economizer saves energy by using cool outdoor air to reduce the demand for air conditioning during shoulder seasons. Free cooling available on wheel models as well.

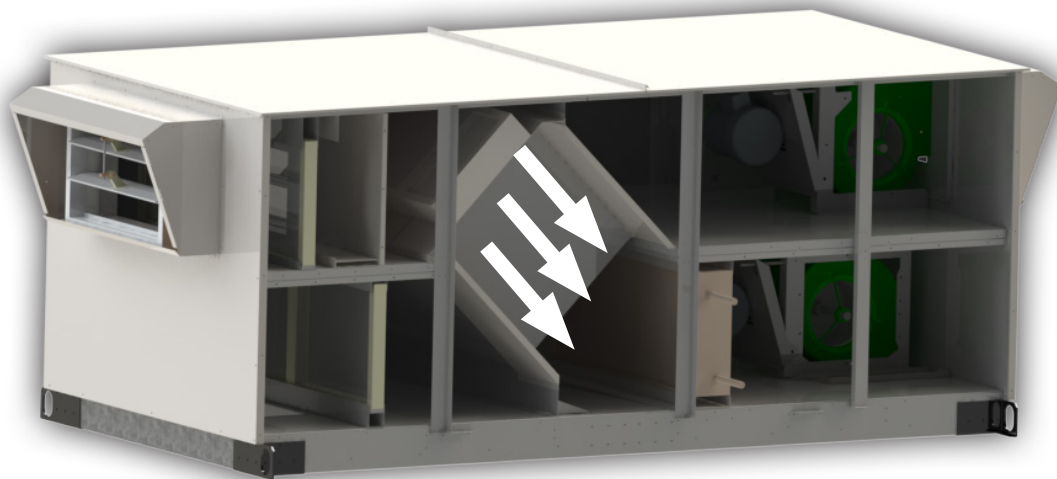

Models are equipped with a PTC (Positive Temperature Coefficient) Temperature Passive Sensor. The sensors are splash proof and are designed to measure temperature in a variety of applications. The Temperature Sensors are two-wire, passive, resistance output devices. These models feature an integral NPT Adaptor to increase sensor connection strength, which eliminates the need for an additional adaptor.

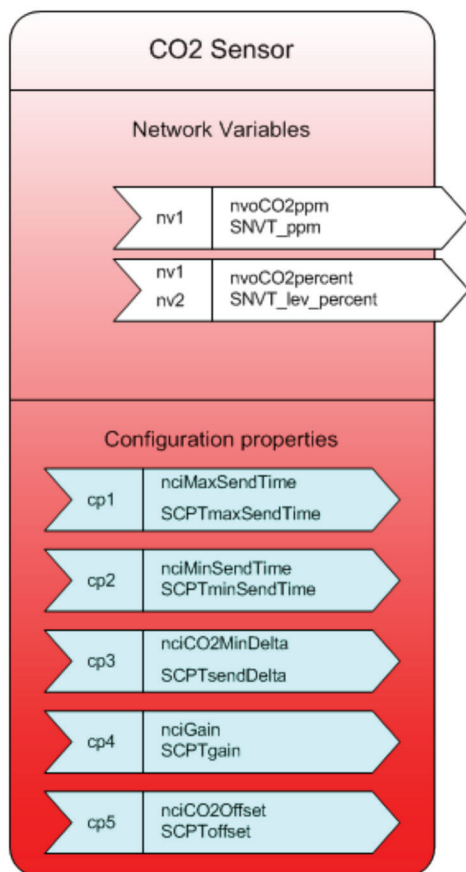

The CO2 transmitter is designed to be self-calibrating and requires no maintenance over the sensor life, which is typically 15-20 years. Built to ISO 9001 standards, The infrared sensor incorporates a unique, patented, oval design. All competitive sensors use a straight path of infrared energy shining through an air sample to measure CO2. The amount of gas that can be sampled, called the “path length” is limited by the size constraints of their wall-mounted and duct-mounted cases used. The design, using a similar sized case, provides over double the path length of any other CO2 sensor (4.8”) by bouncing the light around the small oval sensor element. Longer path length means that a larger sample of air is measured. In technical terms this results in an increased signal-to-noise ratio.

High Efficiency EC Motors (optional)



Available in all models and sizes, EC motors from a German company, offer variable speed control and reduced operating costs. Control these motors based on building ventilation needs to maximize system efficiency and increase ROI.

The EC motor: RH.C-ECblue with integrated electronics is a free running impeller with 7 backwards-curved blades in frame sizes 225-1,120 mm. Impeller made of sheet steel with surface protection provided by powder coating.

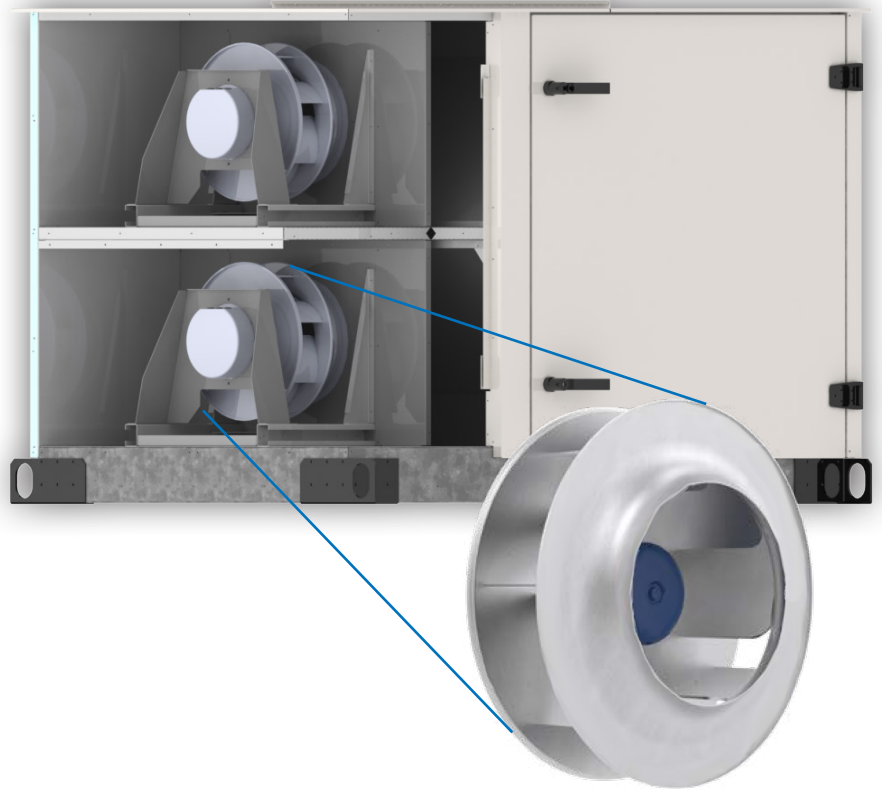

Heating Coils (optional)

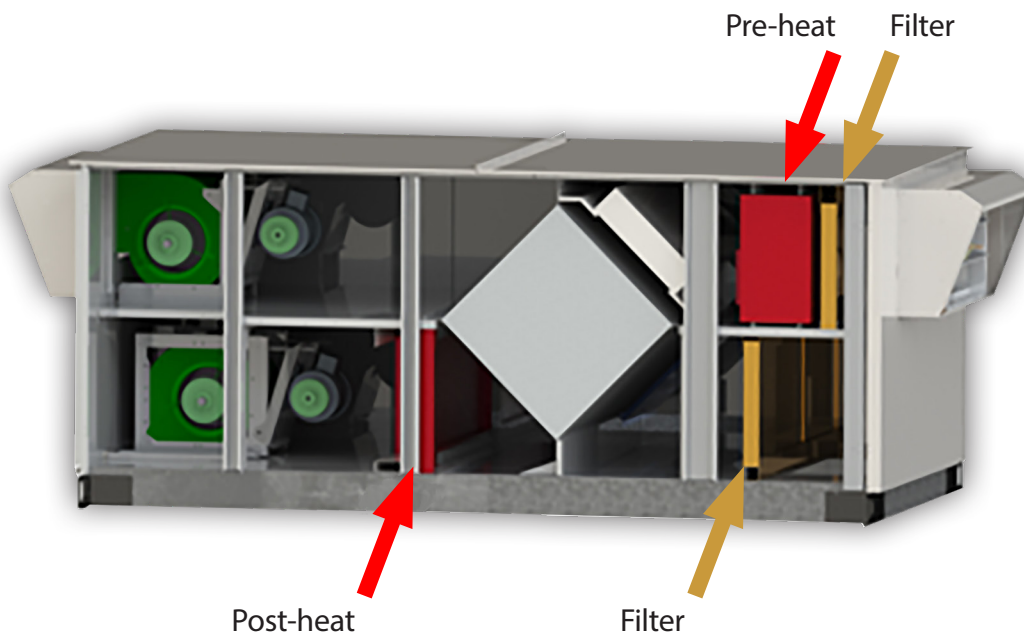

Whether you need pre-heat coils for winter stability, or post-heat coils to maintain supply air temperatures, InspirAIR® Commercial models offer electric or hot water coils to meet the demands of the harshest North American climates and design conditions.

Design & Construction

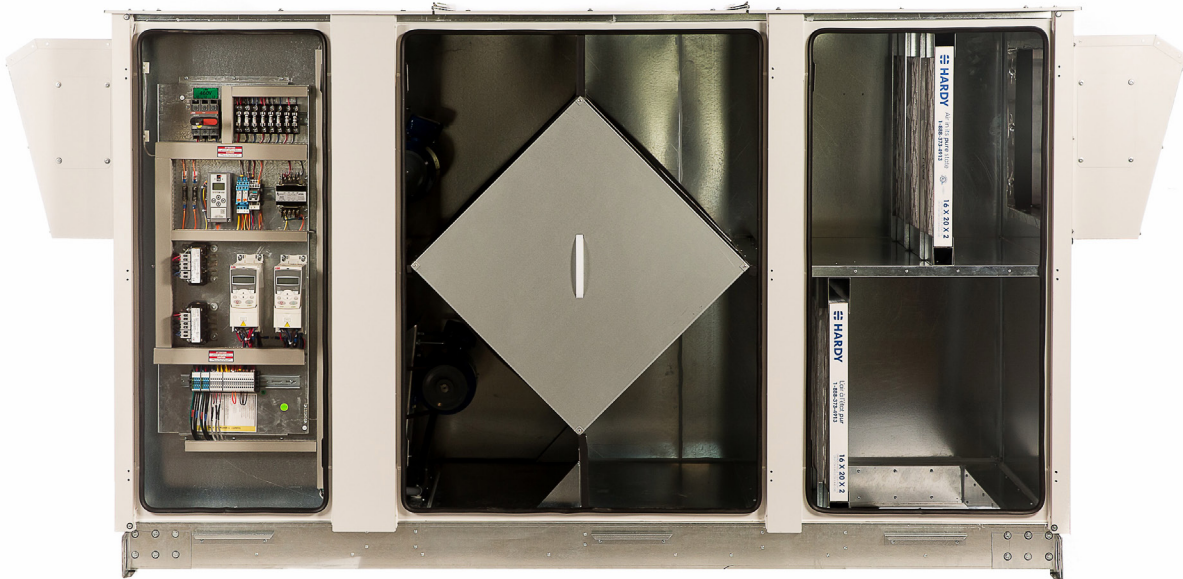

Standard PE outdoor model shown with vertical duct connections..

Duct Configurations

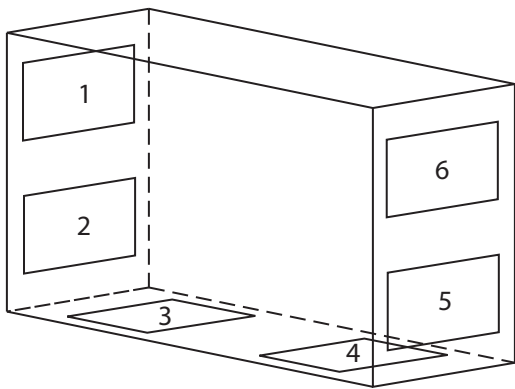

PA, PE, PH Models

AVAILABLE CONFIGURATIONS*
1-2-5-6
1-3-4-6

*Mirror image cabinet also available

DUCT CONNECTION KEY	
1	Exhaust Air (EA)
2,3	Supply Air (SA)
4,5	Return Air (RA)
6	Outside Air (OA)

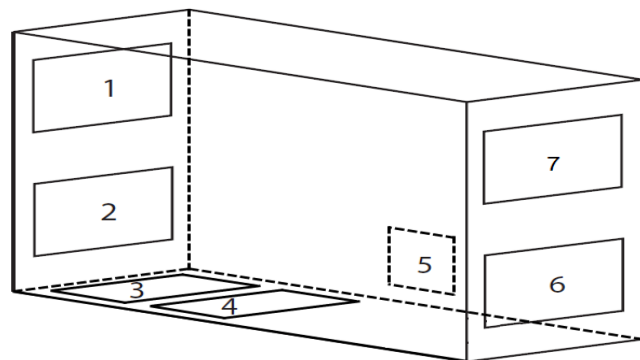

PW Model

AVAILABLE CONFIGURATIONS
1-2-6-7
1-2-5-7
3-4-5-7

DUCT CONNECTION KEY	
1,3	Supply Air (SA)
2,4	Return Air (RA)
5,6	Exhaust Air (EA)
7	Outside Air (OA)

Options

Configuration

- None (Indoor Unit)
- Rooftop Installation (Outdoor Unit)
- Mirror Configuration*

(*Doors are located to the opposite side)

Frost Control

- None (Indoor Unit)

- Exhaust Defrost

Supply air blower shuts down and outside air damper closes. Warm exhaust air defrosts the wheel for a predetermined amount of time.

- Face & Bypass Damper

Standard control dampers assembled either (FBV) one over the other, (FBH) beside each other or (FBR) at right angle from each other. The units are interconnected for simultaneous blade action, typically causing one damper to open while the other closes.

- Pre-Heat (Electrical Coil)

The first element in the air stream following the intake and prefilter, which protect the rest of the system and building from freezing air. Frequently, this heating element is a coil that uses electricity as an energy source.

- Pre-Heat (Hot Water Coil)

The first element in the air stream following the intake and prefilter, which protect the rest of the system and building from freezing air. Frequently, this heating element is a coil that uses hot water as an energy source.

- Recirculation Defrost

Exhaust air blower shuts down, outside air damper closes, exhaust air damper (optional) closes, and recirculation damper (included) opens. Exhaust air warms up for a predetermined amount of time.

- Wheel Speed Defrost (with VFD)

As the outdoor air temperature drops, speed modulation slows the wheel down reducing the heat transfer effectiveness thus ensuring that exhaust air does not reach saturation. This eliminates both condensation and frosting.

Add-Ons

- Dirty Filter Sensor

Will close a dry contact when dirty filters are detected.

- Fan Rotation Sensor

Measuring the turning movement of the fan.

- Wheel Rotation Sensor

A dry contact is closed if no rotation is detected.

- BacNET IP Controller

Routing between multiple BACnet/IP networks is specified.

- BacNET MSTP Controller

Master - Slave and the TP stands for Token Passing. Mainly used for connecting field devices to controllers / routers / control applications.

- Carbon Dioxide (CO₂) Detection

Measures and reports both carbon and oxygen levels.

- Relative Humidity (RH) Detection

Measures and reports both moisture and air temperature.

- Free Cooling Management

Using low external air temperatures to assist in chilling.

- MERV 13 Filter Set (replacement filter)

Minimum Efficiency Reporting Value Filter.

- MERV 8 Filter Set (spare filter set)

Minimum Efficiency Reporting Value Filter.

- Motorized Damper OA

Regulates the outside air flow.

- Motorized Damper EA

Regulates the exhaust air flow.

Electrical Requirements

- 208V/3ph/60Hz

- 208V/1ph/60Hz (AC motor only)

- 230V/3ph/60Hz

- 230V/1ph/60Hz (AC motor only)

- 460V/3ph/60Hz

- 575V/3ph/60Hz (AC motor only)

Maintenance

Aldes heat and energy recovery ventilators are specifically designed to allow easy access to filters, blower assemblies, and heat exchangers. For security to the customer, each unit carries a two-year warranty on both core and wheel assemblies, and a limited two year warranty on all other covered components.

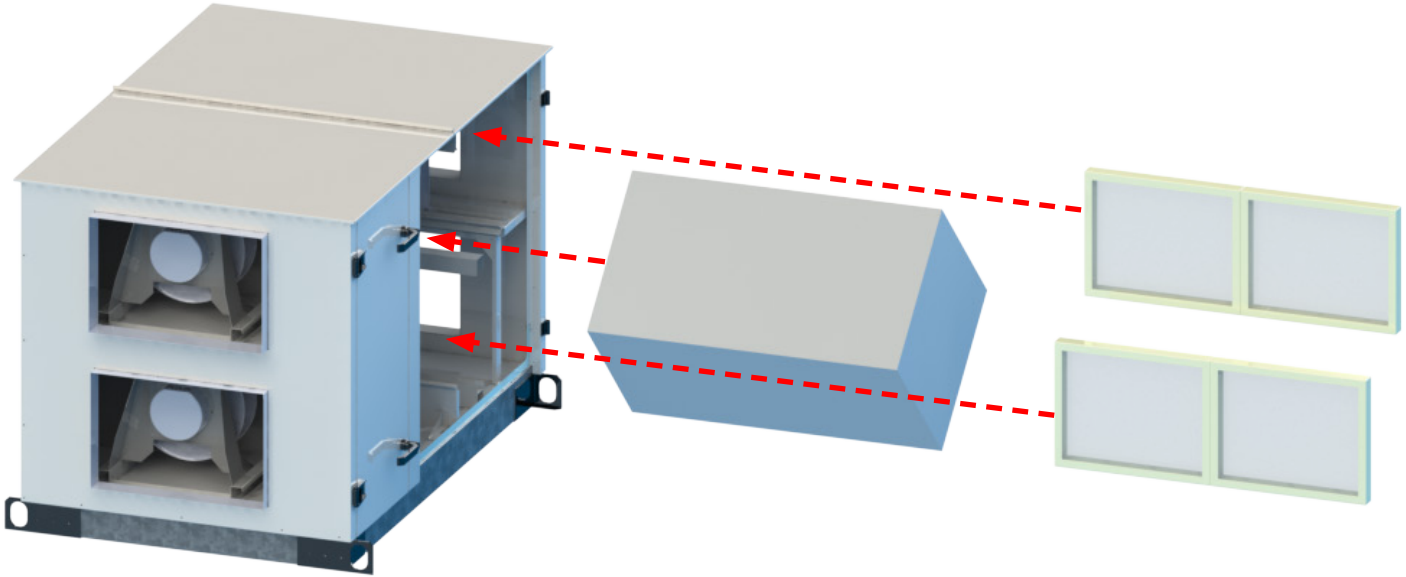

By opening the access doors both the filters and core can easily be removed for replacement or cleaning.

Controller Wiring Diagram

Equipped with the backlit display it's compatible with the Distech Controls' ECB series BACnet® Controllers and BACnet/IP and Wi-Fi Controllers. Offers the "4-in-1" communicating sensor: Multi-sensing capabilities (temperature, humidity, CO₂, and motion) using one wire and one connection. The display receives both power and communications from a single Category 5e cable.

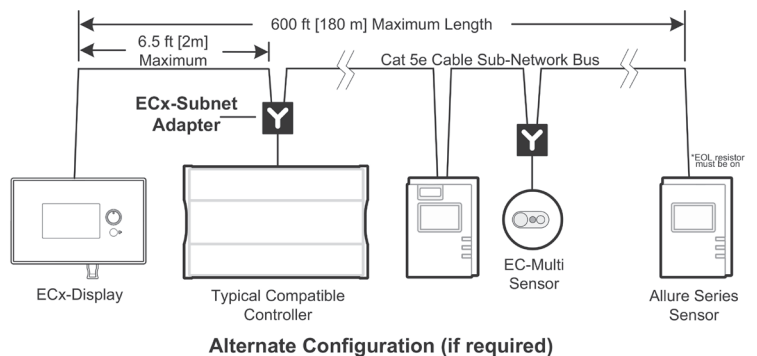
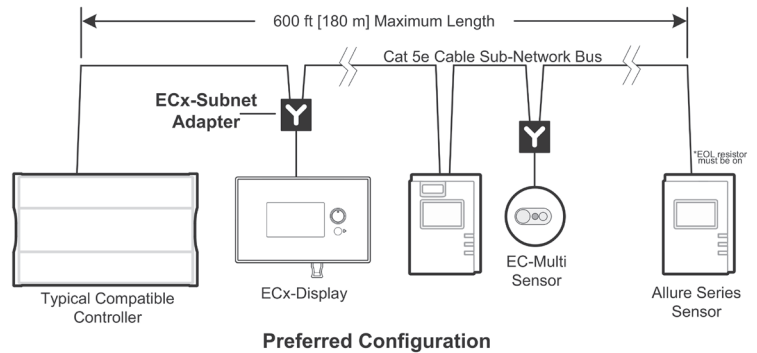

Typical Applications



COMMERCIAL OFFICE BUILDINGS

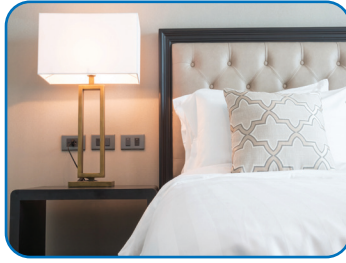

HOTELS



SCHOOLS



INDUSTRIAL / MANUFACTURING

- Each unit is built from the inside out with standard double-wall, heavy-gauge steel cabinets
- Every element is engineered to endure the rigors of day-to-day use for years without fail

- Every unit is AHRI certified to Standard 1060
- Choose from all available methods of sensible only and sensible and latent heat recovery for maximum energy savings
- Units are designed to integrate with building equipment for total HVAC synergy

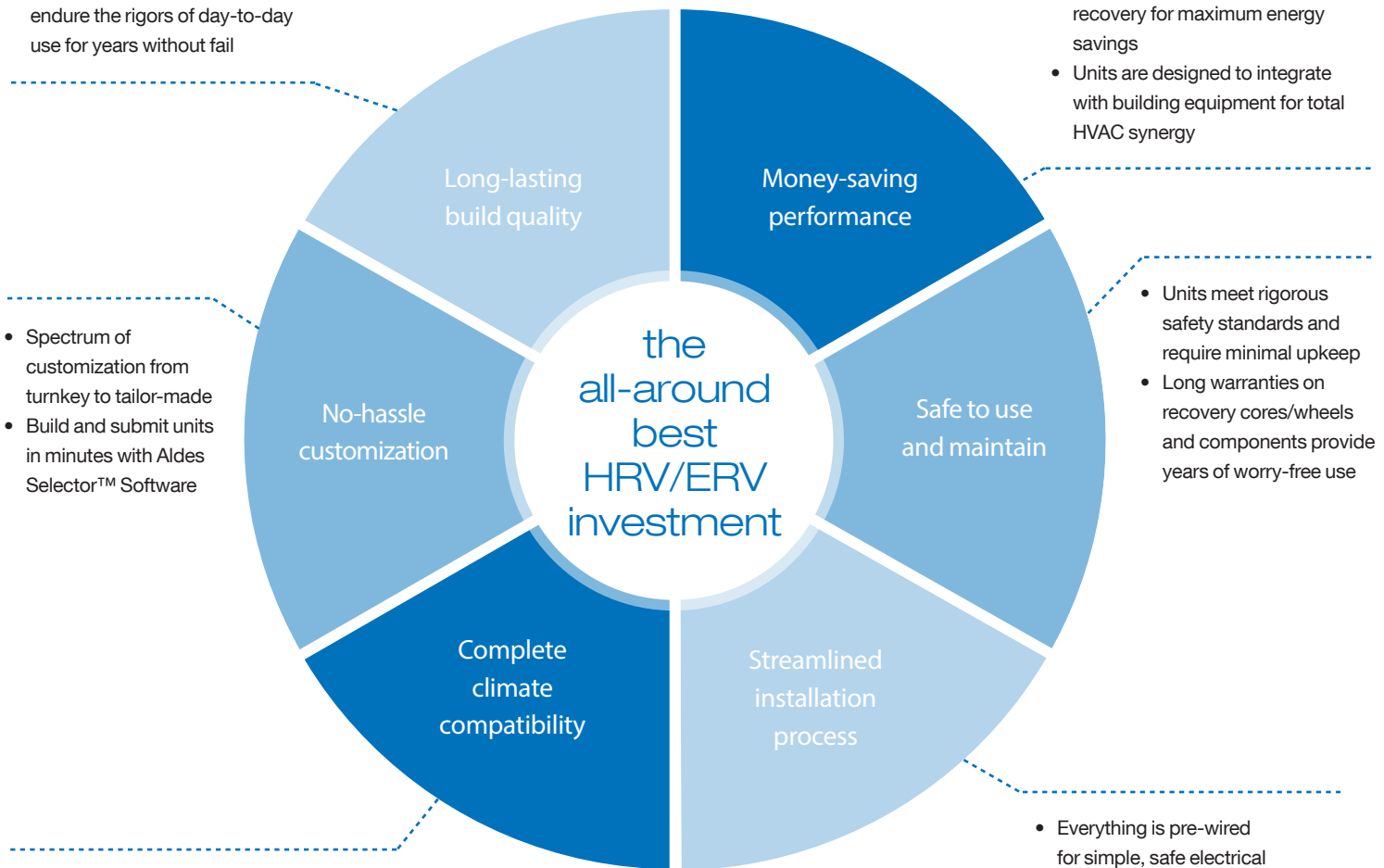

- Spectrum of customization from turnkey to tailor-made
- Build and submit units in minutes with Aldes Selector™ Software

- Units meet rigorous safety standards and require minimal upkeep
- Long warranties on recovery cores/wheels and components provide years of worry-free use

- Models can be installed indoors or outdoors
- Multiple frost-control strategies are available, as are heating and cooling coils for added thermal conditioning

- Everything is pre-wired for simple, safe electrical connections and reduced set-up time
- Multiple configurations, including mirror image cabinets, are available for orienting the unit to the space

#HealthyLiving

Engineering tomorrow's solutions is more than an idea – it is a guiding principle. Every Aldes product is equal parts innovation and experience. Efficient and respectful solutions of the environment which allow to renew and purify the indoor air delivering improved air quality. From automatic airflow controls to advanced heat and energy recovery ventilators, Aldes products can be found in high-performing homes, schools, hotels and buildings across North America. Healthy Living, much more than a movement, embody our benevolence, our sense of responsibility and pioneering spirit.



For more information, contact your
Aldes sales advisor, visit aldes-na.com,
or find us on



Aldes North America
USA 800.255.7749 CAN 800.262.0916

12/20 - InspiAIR Commercial Brochure
©2021 American ALDES Ventilation Corporation and ALDES Canada. All Rights Reserved.
Reproduction or distribution, in whole or in part, of this document, in any form or by any means, without the express written consent of American ALDES Ventilation Corporation and/or ALDES Canada, is strictly prohibited.
The information contained within this document is subject to change without prior written notice.

