



InspirAIR™ HOME STANDARD RESIDENTIAL E110-TF Energy Recovery Ventilator

PRODUCT
SPECIFICATIONS
& TECHNICAL
DATA



PRODUCT DESCRIPTION

Compact size, large performance – the E110-TF energy recovery ventilator produces approximately **101 CFM** at 0.20 in.w.g (ESP) and recovers sensible and latent heat through its high-latent-transfer membrane core. The E110-TF has been thoughtfully engineered for simple installation in apartments, condos, and small houses. The removable collars are top-mounted, which makes the unit both narrow and shallow enough to fit inside standard closets and other tight spaces.

The E110-TF has two exclusive features. EvacMAX™ provides on-demand boost for maximum ventilation. With FLEXControl, airflow circuits can be calibrated electronically, eliminating the need for resistance-inducing balancing dampers and improving overall efficiency.

KEY FEATURES

- Damage-free packaging protects the unit in transit and makes it easy to remove it from the carton without damaging the collars
- Electronically and independently adjustable supply and exhaust blowers (FLEXControl)
- Gauge ports on the door for fast and reliable airflow readings
- Twist-in collars for easy flex-duct attachment
- Non-dust-loading backward-inclined impellers on totally enclosed motors
- Snap-out motor decks
- Easy access to core and filters for cleaning
- Extremely durable core
- Standard MERV 6 filters
- Multiple low-voltage controller options

CASING

Material: Pre-painted 24-gauge galvanized steel
Duct Connections: Ø 4" (Ø 102 mm)
Insulation: Molded EPS
Width: 23-1/8" (587 mm)
Height: 16-3/4" (425 mm)
Depth: 12-3/8" (314 mm)
Weight: 29 lbs (13 kg); Shipping Weight: 37 lbs (17 kg)

MOUNTING

- Suspended by chains with vibration-isolating springs
- Wall-mounting accessory available (P/N: 608575)

RECOVERY CORE

Material: High-latent-transfer membrane

BLOWERS

Quantity: 2
Type: Motorized impellers (backward-inclined)

ELECTRICAL REQUIREMENTS

120 VAC, 60 Hz, 0.6 A, 72 W
Cord Set: 48" (1219 mm) with ground

CONTROLS

Low voltage dry contact (24VAC) for:

- Fan interlock (NO and NC)
- Digital Multifunction Control (P/N: 611242)

Low voltage (24VAC) for:

- Humidity Control (P/N: 611224)
- Speed Control (Low/Intermittent/High) (P/N: 611229)
- 20/40/60 Minute Timer (P/N: 611228)

FROST CONTROL

- Automatic timed integral exhaust defrost
- Activated by a sensor when the outdoor temperature drops below 14°F (-10°C)

FILTERS

Quantity: 2
Type: MERV 6 (P/N: 612409)

WARRANTY

Core Assembly: Limited 5-year warranty
All Other Covered Components: Limited 5-year warranty

APPROVALS

Meets Standards:
• C22.2 no113
• UL 1812



Dimensions

TOP VIEW

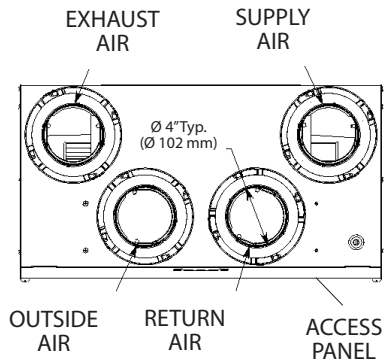

SIDE VIEW

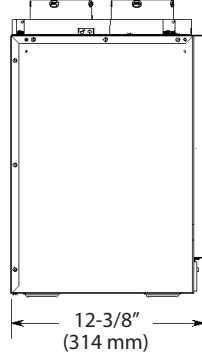

FRONT VIEW

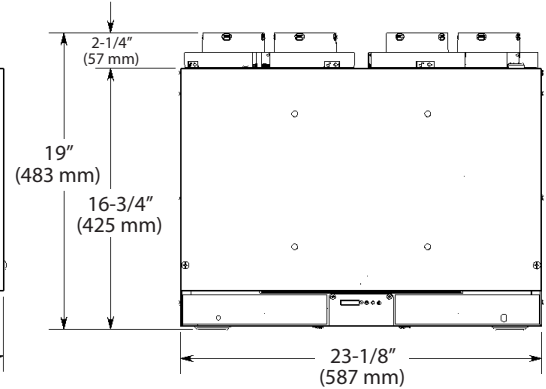

Performance



E110-TF Ventilation Performance

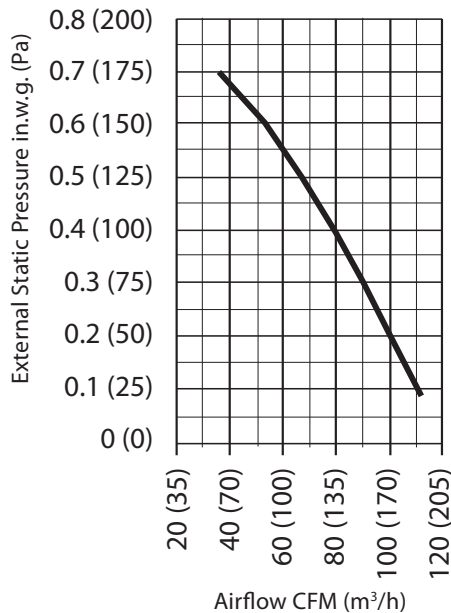

Recovery Performance

Outside Air Temperature		Net Airflow		Power Consumed (W)	Sensible Recovery Efficiency	Apparent Sensible Effectiveness	Latent Recovery/Moisture Transfer	Total Recovery Efficiency
°F	°C	CFM	L/s					
Heating								
32	0	54	26	30	71%	80%	61%	--
32	0	65	31	32	68%	74%	56%	--
32	0	106	50	56	62%	68%	49%	--
-13	-25	50	23	35	61%	77%	56%	--
Cooling								
95	35	51	24	30	--	--	--	54%

Project:		Architect:	
Location:		Engineer:	
Model #:		Contractor:	
Quantity:		Comments:	
Submitted By:			
Date:			

© 2016 American ALDES Ventilation Corporation. Reproduction or distribution, in whole or in part, of this document, in any form or by any means, without the express written consent of American ALDES Ventilation Corporation, is strictly prohibited. The information contained within this document is subject to change without prior written notice.