





RESIDENTIAL SYSTEM SOLUTIONS
VZ Expansion Kit
For VentZone® VZ Zoned Intermittent Bath Exhaust Kits

PRODUCT
SPECIFICATIONS
& TECHNICAL
DATA

The VZ Expansion Kit is for use with VentZone® Systmes VZ Zoned Bath Exhaust Kits. Each expansion kit extends the use of the VZ kit to another bathroom. Up to 3 expansion kits can be added to a basic VZ kit.

Expansion Kit for Zoned Bath Kits			
Part Number	Kit	4" ZRT-1 (120 VAC)	4" x 4" x 4" Wye
			



ZRT-1



4" x 4" x 4"
Wye

© 2016 American ALDES Ventilation Corporation. Reproduction or distribution, in whole or in part, of this document, in any form or by any means, without the express written consent of American ALDES Ventilation Corporation, is strictly prohibited. The information contained within this document is subject to change without prior written notice.



AIRFLOW & ZONE CONTROLS

ZRT[®]

Zone Register Terminals

PRODUCT
SPECIFICATIONS
& TECHNICAL
DATA

GENERAL

American Aldes patented* Zone Register Terminals (ZRT[®]) are designed to introduce flexibility and on-demand control to central ventilation systems. Used in both large and small systems, the ZRT[®] zonally regulates ventilation without the need for individual fans. Each ZRT[®] is a combination grille, register box, control damper, and optional flow regulator(s). This unique combination provides up to four different control schemes without the need for expensive pneumatic, electronic, or DDC control systems. To ensure the proper calibration of the damper assembly, do not exceed 1.0 in. w.g. (250 Pa) of differential pressure across the damper door.

By replacing static grilles in large central exhaust systems, the ZRT-1 model provides on-off control for on-demand ventilation. This allows central fan downsizing and promotes energy savings by minimizing necessary fan horsepower and ventilation-induced heating and cooling loads on the building. The optional Constant Airflow Regulator (CAR-II) can be installed in the ZRT-1's extended duct collar to place a maximum flow limit on each terminal. The automatic operation of the CAR-II will prevent noise and excessive energy consumption caused by over-ventilation, as well as fluctuations in airflow rates as total system pressure varies.

The ZRT-2 model can be used for combination low-flow indoor air quality ventilation and on-demand high-flow spot ventilation using the same central fan system. This is achieved by integrating a minimum Constant Airflow Regulator (CAR-II) directly into the damper sub-assembly. With the damper completely closed, the factory-calibrated CAR-II will still allow steady, low-continuous ventilation during fan operation (consult the CAR-II specifications sheet for sizing and specifying information). When other ZRT[®] are opened for on-demand control of spot ventilation, the closed ZRT-2 will maintain the specified low-continuous rate through the minimum CAR-II. By opening the ZRT-2's control damper, the low-flow CAR-II is removed from the air stream, allowing either controlled (optional using a second CAR-II) or full maximum-boost ventilation.

The ZRT[®] can activate fans used in smaller central exhaust ventilation systems. Through

ZRT[®] Models

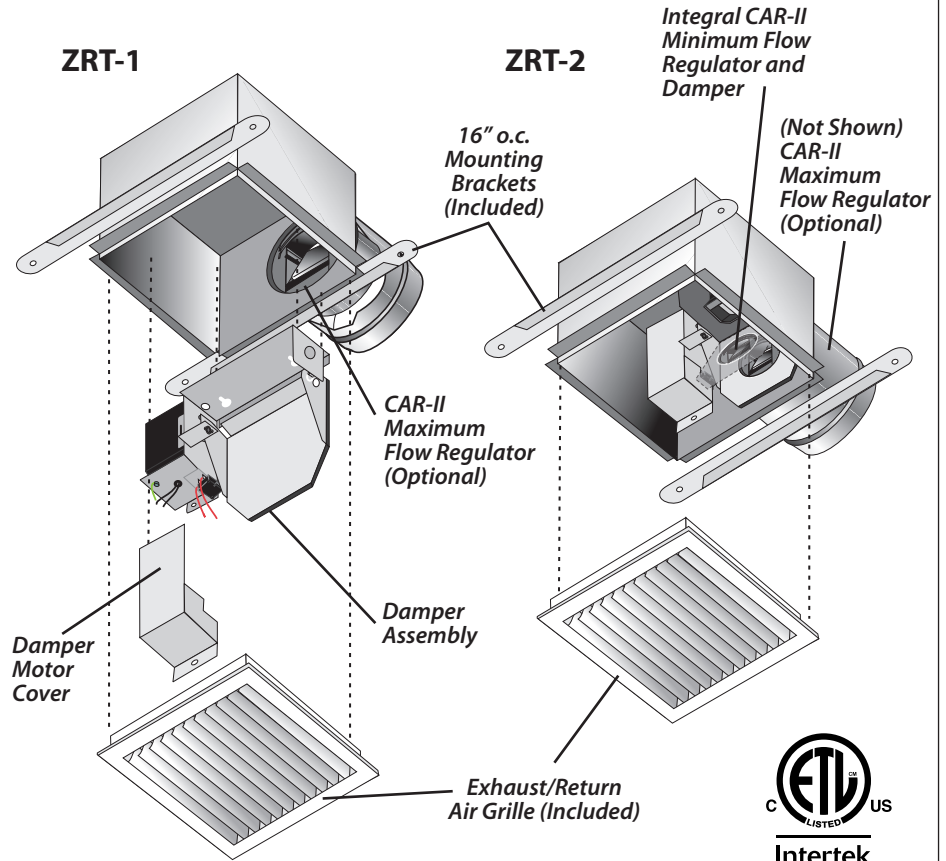

ZRT[®] Dimensions

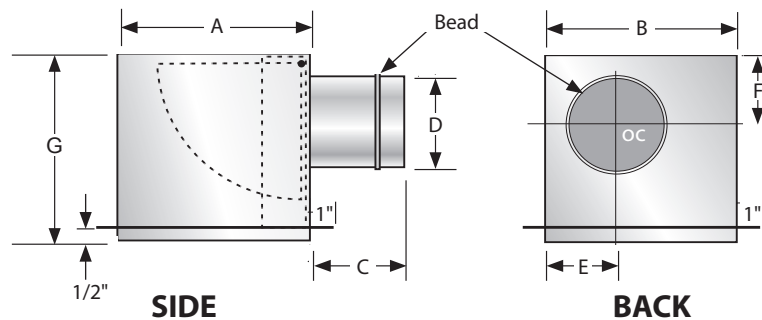

SIZE	A	B	C	D	E	F	G
4"	8"	8"	4-1/2"	3-7/8"	2-1/2"	3-1/2"	7"
6"	10"	10"	5-1/2"	5-7/8"	3-1/2"	4-1/2"	8-1/2"

*U.S. Pat. No. 7,766,734

the use of an integral damper end-switch, the ZRT® can trigger the remote fan to start. This provides the distinct advantage of allowing the fan to only ventilate specific spaces when called upon, without the need for separate fans in each space. This is especially important in residential bath exhaust applications using popular in-line and multi-port fans, where low noise and a single exterior vent penetration are desired.

The ZRT® is available with wireless communication relays that respond to occupancy-based control systems for applications such as hotels, dormitories, apartments, etc. These communication relays are available from American Aldes or the room control manufacturer, but they are always installed by American Aldes*.

CONSTRUCTION

The ZRT® is constructed of a heavy-gauge galvanized steel housing for durability. Units are designed for installation in all ceiling types, with an overall height that allows location between floors using 10-inch or larger joist construction. The extended duct collar allows for simple attachment to rigid or flexible ducting, and insertion of an optional Constant Airflow Regulator (CAR-II) for maximum flow control. An integral steel mounting flange assembly encapsulates the ceiling opening and allows for simple attachment of American Aldes white all-aluminum flush-mount exhaust/return grilles. Contact factory to request custom grilles.

The damper assembly is provided with a long-life 24 VAC or 120 VAC actuator motor with spring return. An optional damper end-switch is available to allow signaling of a remote fan to activation. The gasketed tight-seal damper blade prevents air leakage and noise in the closed position. A solid one-piece damper that pivots

on permanently lubricated bearings is used to support the blade assembly and to prevent deflection caused by motor torque and exposure to air velocity. The entire damper assembly can be installed or removed from below the register box without disconnecting the duct or removing the box from the ceiling.

CONTROL

The ZRT® can be activated using a variety of control options, including wireless communication relays*, on-off or timer switches, dehumidistats, occupancy sensors, or time-clock switches. Any on-off control device(s) will signal the damper to open fully, providing maximum ventilation control. Upon disconnecting the power, the ZRT's integral spring will return the damper blade to its normally closed position.

A Zone Terminal Fan Control Center (model ZTC) is available for use with up to (8) 24 VAC ZRT®.

Airflow control for both maximum and minimum flow rates is achieved using optional, integral, dynamic Constant Airflow Regulators (CAR-II). The CAR-II is an automatic modulating orifice that regulates airflows to constant levels in response to duct pressure. They require no additional power supply and are ideally suited for use in zone-controlled systems where duct pressures can fluctuate in response to the opening and closing of dampers.

MAINTENANCE

The ZRT® needs no maintenance when used in normal conditions. If the intended application includes air heavily loaded with grease or dust, a filtered grille is recommended.

Reading the Model Code

OPTIONAL MAXIMUM CFM
 10, 15, 20, 25, 30, 35, 40, 45, 50, or 60 (4" models)
 75, 90, 105, 125, 140, 160, or 175 (6" models)

OPTIONAL MINIMUM CFM[†]
 10, 15, 20, 25, or 30 (4" models)
 10, 15, 20, 25, 30, 35, 40, 45, 50, 60, 75, 90, or 105 (6" models)

MODEL
 ZRT = Zone Register Terminal

MOTOR VOLTAGE
 24 = 24 VAC
 120 = 120 VAC

Example ZRT - 2 - 4 - 24 MAX - 60 / 20 WCA

SERIES
 1 = No Minimum Flow Control
 2 = With Minimum Flow Control

MAXIMUM FLOW CONTROL
 "Blank" = No Maximum Flow Control
 MAX = With Maximum Flow Control

SIZE
 4 = 8" x 8" w/4" collar
 6 = 10" x 10" w/6" collar

WIRELESS COMMUNICATION OPTIONS
 "Blank" = None
 WCA* = Wireless communication relay provided and installed by Aldes
 FMA* = Communication relay provided by others and installed by Aldes
 WCOSG = Stand-alone occupancy sensor and communication relay by Aldes
 WCWS = Stand-alone wireless wall switch and communication relay by Aldes

[†]Minimum setpoint must be lower than maximum setpoint

*Wireless communication relays by Telkonet®, InnCom®, or Magnum Energy Solutions™ only. Contact factory for availability of controls by others.

How the CAR-II Works

Constant airflow is achieved by controlling the free area through the device. At minimum static pressure, the aero-wing is parallel to the air stream. As the static pressure increases, the aero-wing lifts, reducing the amount of free area through the regulator. At the same time, higher static pressure increases the air velocity resulting in **CONSTANT AIRFLOW**. This occurs regardless of pressure differences in the range of 0.2 to 0.8 in. w.g. (50 to 200 Pa). The air velocity in the duct is in the range of 60 to 700 ft/min. (0.3 to 3.5 m/s).

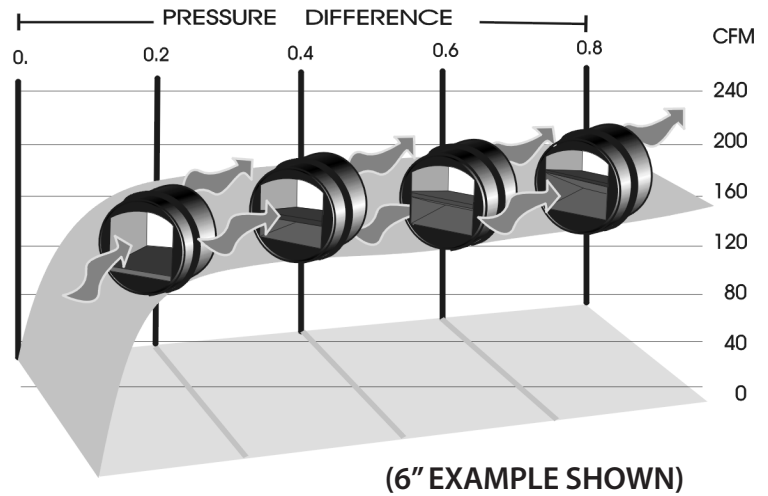

ZRT® Airflow Regulator Performance

Performance curves reflect airflow measurements taken at 68°F (20°C) at 1 atmosphere pressure. The CAR-II is capable of maintaining constant airflow within +/- 10% of scheduled flow rates (15% for units 15 CFM or less) within the operating range of 0.2 to 0.8 in. w.g. differential pressure.

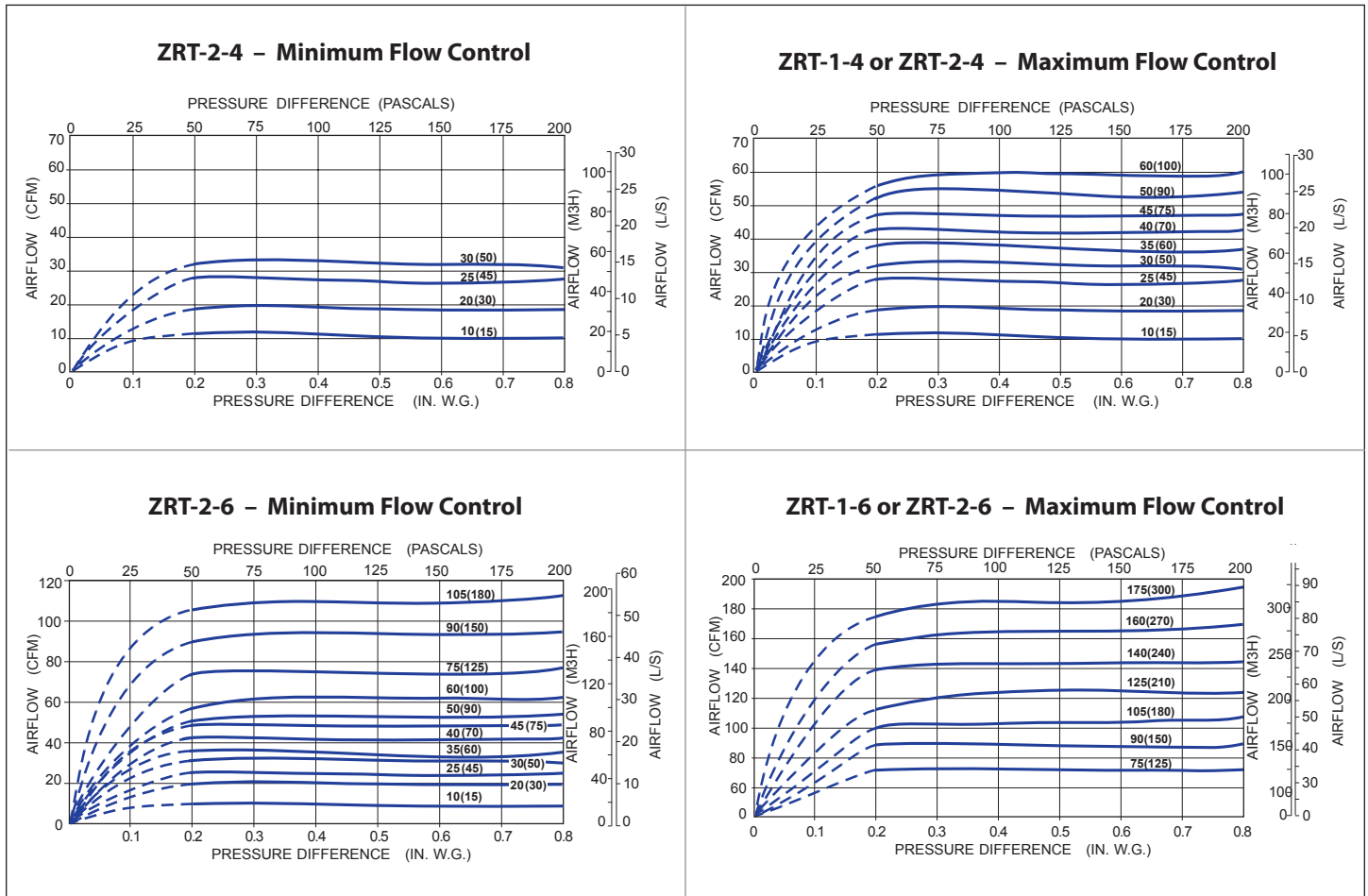

ZRT® Acoustic Performance

	AIRFLOW			0.2 in. w.g. (50 Pa)			0.4 in. w.g. (100 Pa)			0.6 in. w.g. (150 Pa)			0.8 in. w.g. (200 Pa)		
	CFM	m³/h	L/s	Lw-dB(A)	Lw-NR	Lw-NC	Lw-dB(A)	Lw-NR	Lw-NC	Lw-dB(A)	Lw-NR	Lw-NC	Lw-dB(A)	Lw-NR	Lw-NC
Damper Closed w/4" Minimum Flow Control	10	15	4	24	22	21	28	25	24	31	28	26	34	30	29
	20	30	8	25	22	21	30	25	24	34	29	27	37	31	30
	25	45	13	27	24	22	32	26	25	35	30	28	38	32	31
	30	50	14	28	24	22	33	27	25	36	30	28	39	32	31
	35	60	17	31	28	26	37	33	30	38	33	31	42	36	35
	45	75	21	32	28	26	37	33	30	39	34	32	42	37	36
	50	90	25	32	29	26	38	34	31	40	34	33	44	40	38
	60	100	28	34	30	27	39	34	32	41	35	34	43	41	39
Damper Open w/6" Maximum Flow Control	75	130	36	31	27	25	34	32	31	39	36	35	42	39	38
	90	150	42	33	28	27	37	34	33	41	37	35	45	39	38
	105	180	50	34	28	27	40	35	33	44	38	36	46	40	39
	125	210	59	34	29	28	40	36	34	42	37	35	44	38	37
	140	240	67	35	30	28	41	37	34	44	38	36	47	40	39
	160	270	76	37	31	29	43	38	35	45	39	38	49	43	41
	175	300	84	38	32	30	44	39	36	46	41	39	50	44	42

Typical Specification

Furnish and install model ZRT® Zone Register Terminals by American ALDES Ventilation Corporation or approved equal. The exhaust terminals shall be of sizes and capacities and at locations scheduled on the drawings. The terminal casing shall be minimum 24-gauge G90 galvanized steel with an integral duct collar that allows attachment of both rigid and flexible ducting. The collar shall be sized to allow full insertion of a model CAR-II Constant Airflow Regulator for maximum flow control, but without the regulator extending into attaching duct. All terminals must be listed per UL standards and carry the UL or ETL mark indicating compliance. Each ZRT® shall include all necessary mounting brackets and hardware.

The primary air volume mechanism shall be a single-blade damper operated by a long-life 24 VAC or 120 VAC disconnecting-type drive motor with normally closed spring-return closure. When fully open, the damper shall rotate out of the air stream on a solid one-piece damper that pivots on permanently lubricated bearings. A permanently fixed perimeter gasket seal shall be provided to prevent air noise and leakage at the closed position. The ZRT® must be capable of overcoming a minimum of 1.0 in. w.g. (250 Pa) of differential pressure across the damper door. The entire damper assembly and all operable parts shall be capable of being removed from the terminal housing from below without disconnecting duct or removing the housing.

Where indicated on the drawings or schedule, a minimum CAR-II airflow modulating control device shall be incorporated into the damper assembly. The control device shall respond to changes in duct pressure to maintain specified flow rates at a constant level. The minimum CAR-II shall be calibrated at the factory. Mechanical damper stops are not acceptable. Where a maximum flow is indicated on the drawings and/or schedule, a model CAR-II Constant Airflow Regulator shall be installed in the terminal's duct collar. VAV terminal units with analog electronic or direct digital controls may be used as an alternative. Installation shall be per all applicable codes and manufacturer's instructions.

WARRANTY

The entire unit is guaranteed for three (3) years, from date of shipment, against all manufacturing defects, provided the material has been installed and operated per manufacturer's instructions and under normal conditions. Warranty is limited to the repair or replacement of the material upon its return freight paid to our factory. This warranty is not transferable and is limited to the original end user.

© 2015 American ALDES Ventilation Corporation. Reproduction or distribution, in whole or in part, of this document, in any form or by any means, without the express written consent of American ALDES Ventilation Corporation, is strictly prohibited. The information contained within this document is subject to change without prior written notice.



ROOF CAPS, WALL HOODS, GRILLES & DUCT FITTINGS

Wyes
4" - 10"

PRODUCT
SPECIFICATIONS
& TECHNICAL
DATA

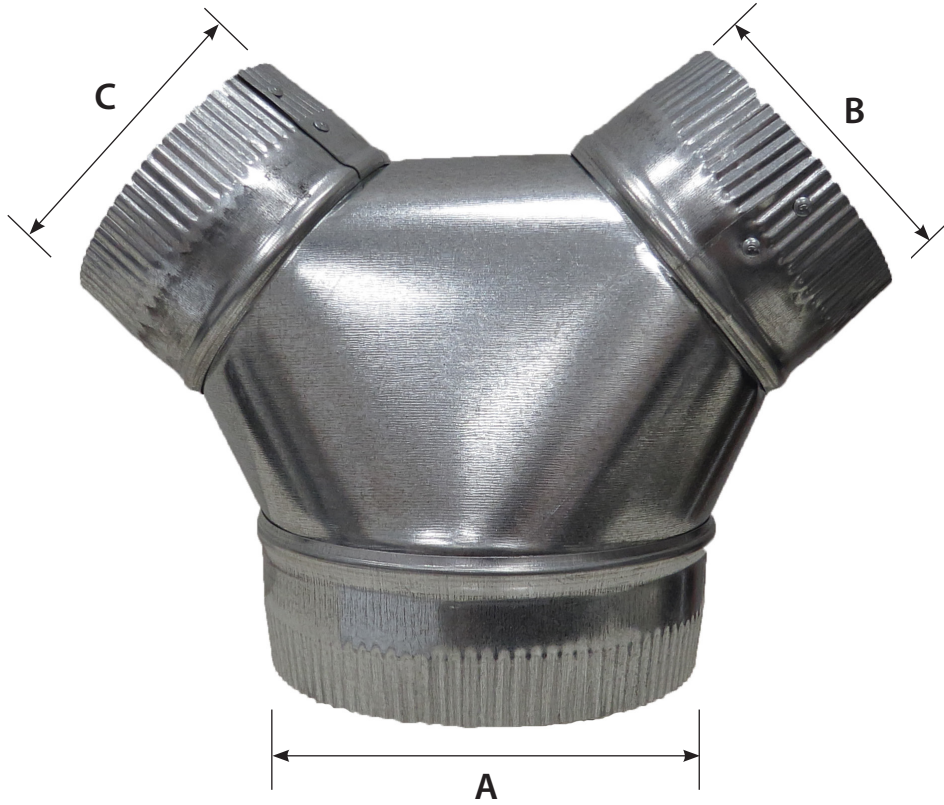

DIMENSIONAL DATA			
PART NUMBER	DIA. A	DIA. B	DIA. C
93 081	4"	3"	3"
93 082	4"	4"	4"
93 087	5"	4"	4"
93 083	5"	5"	5"
93 086	6"	4"	4"
93 085	6"	5"	5"
93 084	6"	6"	6"
93 090	8"	8"	8"
93 091	8"	6"	6"
93 094	10"	10"	10"
93 095	10"	8"	8"

© 2013 American ALDES Ventilation Corporation. Reproduction or distribution, in whole or in part, of this document, in any form or by any means, without the express written consent of American ALDES Ventilation Corporation, is strictly prohibited. The information contained within this document is subject to change without prior written notice.