



STANDARD COMMERCIAL
SH2000i
Heat Recovery Ventilator

PRODUCT
SPECIFICATIONS
& TECHNICAL
DATA



NOMINAL CAPACITY
1000-2000 CFM

CASING – STANDARD

- Double-wall cabinet
- 22-gauge galvanized steel interior and exterior
- Access doors with quarter-turn handles
- 22-gauge galvanized steel drain pan
- Drain Connections: 1" NPT
- Insulation: 1" (25 mm)

CASING – OPTIONAL

- Painted white baked enamel outside finish
- Pool Construction: TEFC motors, stainless steel interior, and epoxy-coated fans
- Removable access panels

MOUNTING – STANDARD

On platform

PLATE EXCHANGER OPTIONS

Polypropylene (sensible heat transfer)

Quantity: 2
Pitch: 0.16" (4 mm)
Dimensions: 21" x 21" x 19-3/8"
(533 mm x 533 mm x 492 mm)



Aluminum (sensible heat transfer)

Quantity: 2
Pitch: 0.17" (4.2 mm)
Dimensions: 19-3/8" x 19-3/8" x 19-3/8"
(492 mm x 492 mm x 492 mm)



BLOWERS & MOTORS – STANDARD OPTIONS

Blowers:

- Quantity: 2
- Forward-curved
- Permanently sealed and lubricated ball bearings
- Power transmission by adjustable pulleys and belts

Motors:

- Type: Inverter duty 10:1
- Maximum Power: 3 hp
- Available Voltage:
 - » 120, 208, 230 V / 1ph / 60Hz
 - » 208, 230, 460, 575 V / 3ph / 60Hz

(See table on page 2 for details)

EC MOTORS – OPTIONAL

Blowers:

- Quantity: 2 (1 per air stream)
- Plenum Type: Backward Inclined
- Permanently sealed and lubricated ball bearings
- Direct Drive

EC Motors:

- Maximum Power:
 - » 1.9 kW at 208-230 V / 3ph / 60Hz
 - » 2.5 kW at 460 V / 3ph / 60Hz
- Available Voltage:
 - » 208, 230, 460 V / 3ph / 60Hz

(See table on page 2 for details)

ELECTRICAL & CONTROLS – STANDARD

- 24 V double motor contactor with start-stop dry contact
- Non-fused disconnect (NEMA 4)
- 24 V transformer for controls

ELECTRICAL & CONTROLS – OPTIONAL

- Fused disconnect
- 24 VAC, 20 VA power available for accessories

FILTERS – STANDARD

Quantity: 2 supply, 2 exhaust
Type: MERV 8
Dimensions: 18" x 20" x 2" (457 mm x 508 mm x 51 mm)

FILTERS – OPTIONAL

MERV 13 Filters (substitute on supply air circuit only)

LISTED BY



SH2000i Features (Continued)

FROST PREVENTION/CONTROL – OPTIONS

If no defrost mode is selected, it is the customer's responsibility to protect the core from freezing.

Frost control activated by a temperature reference: 23°F (-5°C)

Internal Pre-Heat by Electric Coil:

- Powered by unit, SCR control (unavailable with 120 V)

Internal Pre-Heat by Hot Water Coil:

- 0-10 V signal on the control panel
- Piping connections under unit

Exhaust Defrost:

- Supply air blower shuts down and outside air damper closes. Warm exhaust air defrosts the core until it is completely defrosted.
- Includes motorized and insulated damper on fresh air intake (OA)

Recirculation Defrost:

- Exhaust air blower shuts down, outside air damper closes, exhaust air damper (optional) closes, and recirculation damper (included) opens. Exhaust air warms up the core for a predetermined amount of time (see table at right).
- Includes motorized and insulated damper on fresh air intake (OA)

POST-HEAT COILS

Post-Heat by Electric Coil:

- Powered by unit, SCR control (unavailable with 120 V)

Post-Heat by Hot Water Coil:

- 0-10VDC signal to maintain supply air temperature, or 0-10VDC signal by others

OPTIONAL COMPONENTS

- Motorized and insulated damper for exhaust port (EA)
 - » Adds 7" (178 mm) to overall unit width
- Non-insulated backdraft damper for exhaust port (EA)
- Motorized and insulated damper on fresh air intake (OA) (included with exhaust defrost and recirculation)

WARRANTY

- Core Assembly: Limited 10-year
- All Other Covered Components: Limited 2-year

RECIRCULATION DEFROST CYCLE TEMPERATURE			
Outside Temperature		Minutes Defrost/Vent	
°F	°C	Standard	Extended
t > 23	t > -5	N/A	N/A
23 > t > -13	-5 > t > -25	7/25	10/20
-13 > t	-25 > t	10/22	10/15

SH2000i Motor & Blower Options*

		PARAMETERS																	
		HP					VOLTAGE & PHASE								MOTOR SPEED				
		3/4	1	1.5	2	3	1-PHASE			3-PHASE					SINGLE SPEED	2-SPEED		VARIABLE SPEED	
							120 V	208 V	230 V	208 V	230 V	460 V	575 V	MOTOR		VFD	MOTOR	VFD	
MOTOR TYPE & EFFICIENCY†	ODP, EPAct	√	√	√	√		√	√	√					√	√	√		√	
	ODP, Premium					√				√	√	√	√	√		√		√	
	TEFC, EPAct	√	√				√	√	√					√		√		√	
	TEFC, Premium			√	√	√				√	√	√	√	√		√		√	
	EC Motors	N/A								√	√	√		√	√		√		

*See pages 7-8 for motor sizing. See page 8 for EC Motors Power Consumption.

†Premium efficiency required when available.

SH2000i Dimensions

Keep a minimum distance of 42" (1067 mm) in front of the unit and 24" (610 mm) behind it

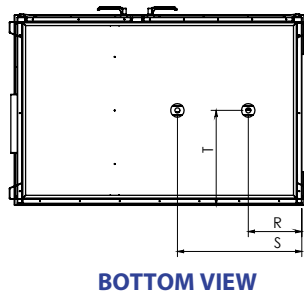
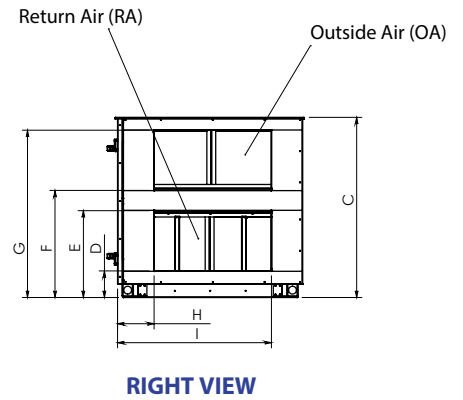
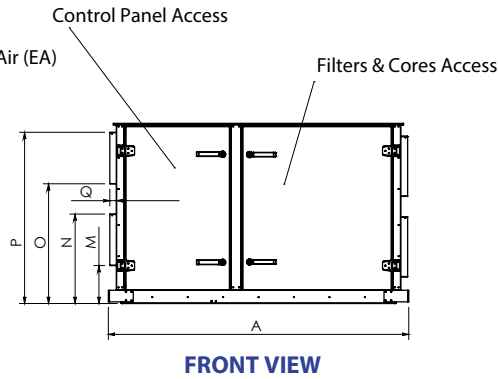
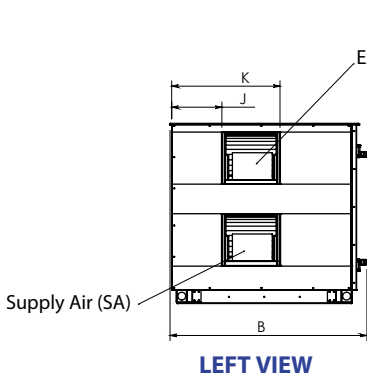
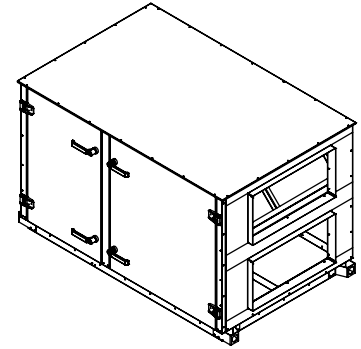
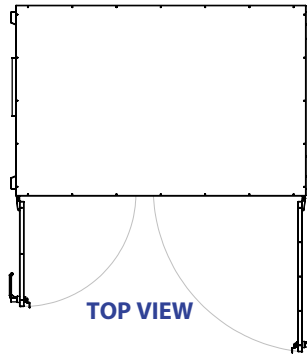

DIMENSIONS in inches (mm)										
Overall					Openings					
A*			B	C	D	E	F	G	H	
Standard	1 Extension	2 Extensions								
66 (1676)	86 (2184)	106 (2692)	46 (1168)	46.75 (1187)	7.75 (197)	21.25 (540)	27.75 (705)	41.25 (1048)	8.25 (210)	
Openings										
I	J	K	M	N	O	P	Q	R	S	T
34.75 (883)	11.375 (289)	24.5 (622)	8.5 (216)	20 (508)	27.75 (705)	39.25 (997)	1.5 (38)	12.125 (308)	28.125 (714)	21 (533)

*Optional motorized and insulated damper for exhaust port (EA) adds 7" (178 mm) to overall unit width

SH2000i Configurations & Weights

AVAILABLE CONFIGURATIONS*
1-2-5-6
1-3-5-6
1-2-4-6
1-3-4-6

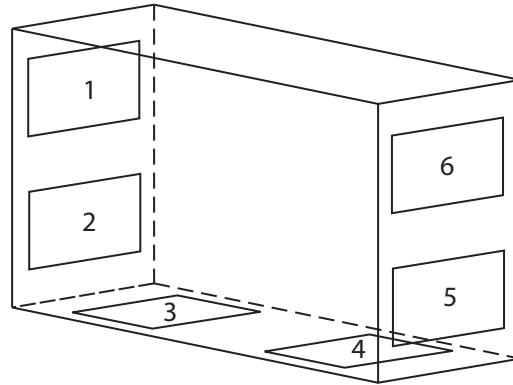

DUCT CONNECTION KEY	
1	Exhaust Air (EA)
2, 3	Supply Air (SA)
4, 5	Return Air (RA)
6	Outside Air (OA)

*Mirror Image Cabinet Also Available

SH2000i WEIGHTS & DIMENSIONS †	
Minimum Unit Weight	635 lbs (288 kg)
Maximum Unit Weight	1270 lbs (576 kg)
Minimum Shipping Weight	680 lbs (308 kg)
Maximum Shipping Weight	1315 lbs (596 kg)

† Actual weight may vary by ±10%.

Polypropylene Core Performance

AHRI STANDARD CONDITIONS	CONDITIONS	
Outside Air Temperature	Winter	Summer
Dry Bulb	35°F (1.7°C)	95°F (35°C)
Wet Bulb	33°F (0.6°C)	78°F (25.6°C)
Exhaust Air Temperature	Winter	Summer
Dry Bulb	70°F (21.1°C)	75°F (23.9°C)
Wet Bulb	58°F (14.4°C)	63°F (17.2°C)

Note: Efficiencies are based on AHRI standard conditions.

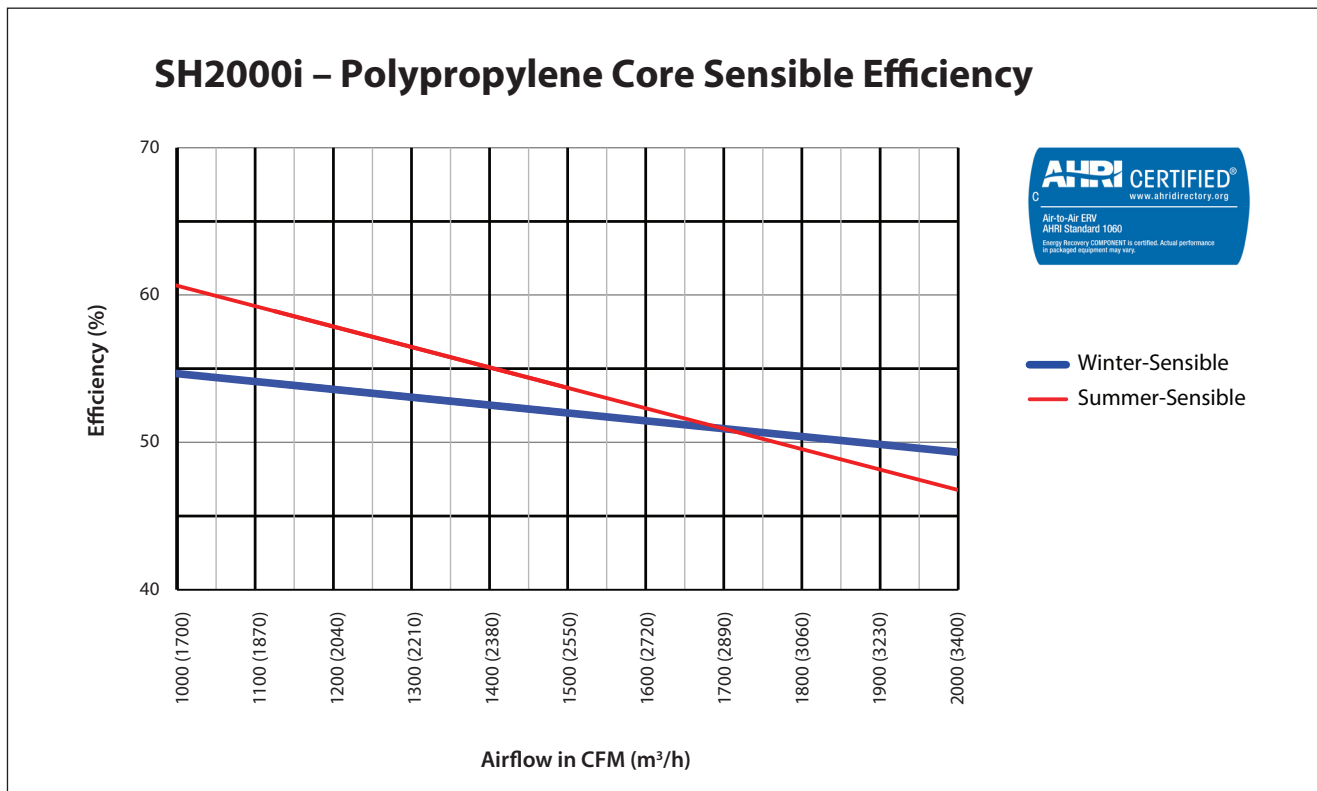

Aluminum Core Performance

AHRI STANDARD CONDITIONS	CONDITIONS	
	Winter	Summer
Outside Air Temperature		
Dry Bulb	35°F (1.7°C)	95°F (35°C)
Wet Bulb	33°F (0.6°C)	78°F (25.6°C)
Exhaust Air Temperature		
Dry Bulb	70°F (21.1°C)	75°F (23.9°C)
Wet Bulb	58°F (14.4°C)	63°F (17.2°C)

Note: Efficiencies are based on AHRI standard conditions.

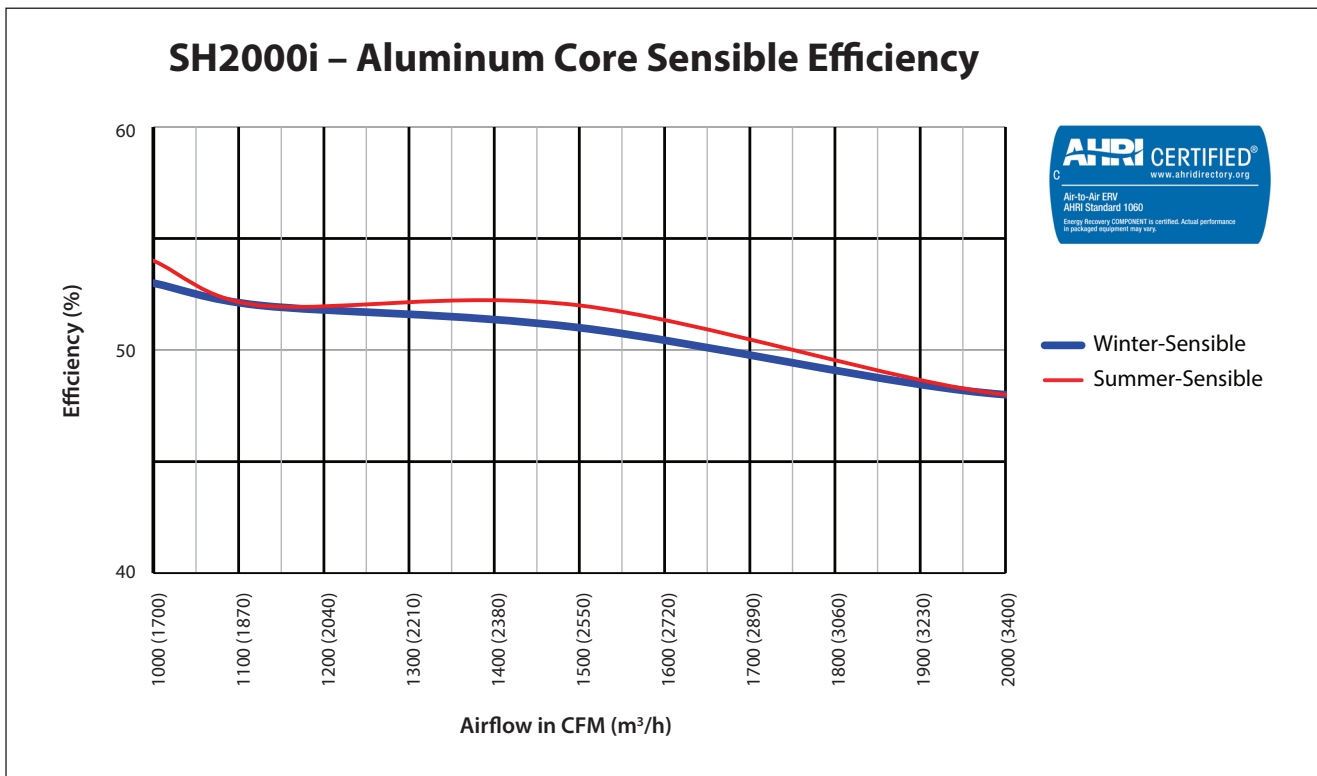

Motor Selection – Polypropylene Core

SUPPLY																				
MOTOR	CFM (m³/h)	EXTERNAL STATIC PRESSURE (inH ₂ O) - SUPPLY																		MOTOR
		0.25 (60 Pa)			0.50 (125 Pa)			0.75 (185 Pa)			1.00 (250 Pa)			1.25 (310 Pa)			1.50 (375 Pa)			
		RPM	BHP	HP	RPM	BHP	HP	RPM	BHP	HP	RPM	BHP	HP	RPM	BHP	HP	RPM	BHP	HP	
3/4 hp	1000 (1700)	896	0.22	0.26	1061	0.32	0.38	1205	0.41	0.49	1331	0.51	0.61	1444	0.62	0.74	1545	0.72	0.86	1 hp
	1100 (1870)	930	0.27	0.32	1089	0.36	0.43	1229	0.47	0.56	1354	0.58	0.70	1467	0.69	0.83	1571	0.80	0.96	
	1200 (2040)	963	0.32	0.38	1114	0.42	0.50	1251	0.52	0.62	1375	0.64	0.77	1488	0.76	0.91	1591	0.88	1.06	1.5 hp
	1300 (2210)	1001	0.37	0.44	1145	0.48	0.58	1278	0.59	0.71	1399	0.71	0.85	1511	0.84	1.01	1614	0.97	1.16	
	1400 (2380)	1039	0.44	0.53	1175	0.55	0.66	1304	0.67	0.80	1423	0.79	0.95	1533	0.92	1.10	1635	1.06	1.27	
	1500 (2550)	1076	0.51	0.61	1205	0.62	0.74	1328	0.74	0.89	1445	0.87	1.04	1553	1.01	1.21	1654	1.15	1.38	
1 hp	1600 (2720)	1117	0.59	0.71	1241	0.71	0.85	1358	0.83	1.00	1471	0.97	1.16	1577	1.11	1.33	1677	1.26	1.51	2 hp
	1700 (2890)	1157	0.68	0.82	1275	0.80	0.96	1388	0.93	1.12	1496	1.07	1.28	1600	1.22	1.46	1699	1.37	1.64	
1.5 hp	1800 (3060)	1196	0.78	0.94	1309	0.90	1.08	1418	1.03	1.24	1522	1.18	1.42	1623	1.33	1.60	1719	1.48	1.78	3 hp
	1900 (3230)	1240	0.89	1.07	1348	1.02	1.22	1452	1.15	1.38	1552	1.30	1.56	1649	1.45	1.74	1743	1.62	1.94	
	2000 (3400)	1282	1.01	1.21	1385	1.14	1.37	1485	1.28	1.54	1582	1.43	1.72	1676	1.59	1.91	1768	1.75	2.10	
2 hp	2100 (3570)	1327	1.14	1.37	1425	1.28	1.54	1522	1.42	1.70	1616	1.57	1.88	1706	1.74	2.09	1794	1.91	2.29	3 hp
	2200 (3740)	1368	1.28	1.54	1462	1.42	1.70	1555	1.57	1.90	1646	1.72	2.06	1734	1.89	2.27	1819	2.06	2.47	
	2250 (3825)	1390	1.36	1.63	1482	1.50	1.80	1573	1.65	2.00	1662	1.81	2.17	1749	1.97	2.36	1833	2.15	2.58	

EXHAUST																				
MOTOR	CFM (m³/h)	EXTERNAL STATIC PRESSURE (inH ₂ O) - EXHAUST																		MOTOR
		0.25 (60 Pa)			0.50 (125 Pa)			0.75 (185 Pa)			1.00 (250 Pa)			1.25 (310 Pa)			1.50 (375 Pa)			
		RPM	BHP	HP	RPM	BHP	HP	RPM	BHP	HP	RPM	BHP	HP	RPM	BHP	HP	RPM	BHP	HP	
3/4 hp	1000 (1700)	815	0.19	0.23	992	0.27	0.32	1144	0.37	0.44	1277	0.47	0.56	1396	0.57	0.68	1503	0.68	0.82	1 hp
	1100 (1870)	826	0.22	0.26	996	0.31	0.37	1147	0.40	0.48	1281	0.51	0.61	1401	0.62	0.74	1510	0.73	0.88	
	1200 (2040)	845	0.25	0.30	1006	0.34	0.41	1154	0.45	0.54	1287	0.56	0.67	1407	0.67	0.80	1517	0.79	0.95	1.5 hp
	1300 (2210)	859	0.29	0.35	1013	0.38	0.46	1156	0.49	0.59	1288	0.60	0.72	1409	0.72	0.86	1519	0.85	1.02	
	1400 (2380)	882	0.34	0.41	1028	0.43	0.52	1164	0.54	0.65	1294	0.65	0.78	1413	0.78	0.94	1524	0.91	1.09	
	1500 (2550)	905	0.39	0.47	1043	0.48	0.58	1176	0.59	0.71	1300	0.71	0.85	1418	0.84	1.01	1528	0.98	1.18	
	1600 (2720)	925	0.44	0.53	1056	0.54	0.65	1183	0.65	0.78	1303	0.77	0.92	1418	0.90	1.08	1527	1.04	1.25	
	1700 (2890)	949	0.51	0.61	1075	0.61	0.73	1195	0.72	0.86	1312	0.84	1.01	1423	0.97	1.16	1530	1.11	1.33	
1 hp	1800 (3060)	974	0.58	0.70	1095	0.68	0.82	1210	0.79	0.95	1323	0.92	1.10	1430	1.05	1.26	1534	1.19	1.43	2 hp
	1900 (3230)	994	0.64	0.77	1112	0.76	0.91	1222	0.87	1.04	1330	0.99	1.19	1435	1.13	1.36	1536	1.27	1.52	
	2000 (3400)	1025	0.73	0.88	1138	0.85	1.02	1245	0.97	1.16	1348	1.09	1.31	1450	1.23	1.48	1547	1.37	1.64	
1.5 hp	2100 (3570)	1047	0.81	0.97	1156	0.94	1.13	1260	1.06	1.30	1359	1.19	1.43	1457	1.32	1.58	1552	1.47	1.76	3 hp
	2200 (3740)	1070	0.90	1.08	1174	1.03	1.24	1275	1.16	1.40	1372	1.29	1.55	1465	1.42	1.70	1559	1.57	1.88	
	2250 (3825)	1087	0.95	1.14	1187	1.08	1.30	1287	1.22	1.50	1382	1.35	1.62	1474	1.49	1.79	1566	1.63	1.96	

NOTES:

hp = bhp x 1.2

Internal static pressure will vary based on selected options.

Motor selections do not apply to EC Motors.

Motor Selection – Aluminum Core

SUPPLY/EXHAUST																				
MOTOR	CFM (m ³ /h)	EXTERNAL STATIC PRESSURE (inH ₂ O) - SUPPLY/EXHAUST																		MOTOR
		0.25 (60 Pa)			0.50 (125 Pa)			0.75 (185 Pa)			1.00 (250 Pa)			1.25 (310 Pa)			1.50 (375 Pa)			
		RPM	BHP	HP	RPM	BHP	HP	RPM	BHP	HP	RPM	BHP	HP	RPM	BHP	HP	RPM	BHP	HP	
3/4 hp	1000 (1700)	896	0.22	0.26	1061	0.32	0.38	1205	0.41	0.49	1331	0.51	0.61	1444	0.62	0.74	1545	0.72	0.86	1 hp
	1100 (1870)	916	0.26	0.31	1077	0.36	0.43	1218	0.46	0.55	1345	0.57	0.68	1458	0.68	0.82	1563	0.79	0.95	
	1200 (2040)	937	0.30	0.36	1091	0.40	0.48	1230	0.51	0.61	1356	0.62	0.74	1470	0.74	0.89	1575	0.86	1.03	1.5 hp
	1300 (2210)	965	0.35	0.42	1112	0.45	0.54	1247	0.56	0.67	1372	0.68	0.82	1485	0.81	0.97	1590	0.94	1.13	
	1400 (2380)	988	0.40	0.48	1127	0.51	0.61	1259	0.62	0.74	1381	0.75	0.90	1494	0.87	1.04	1599	1.01	1.21	
	1500 (2550)	1017	0.46	0.55	1149	0.57	0.68	1275	0.69	0.83	1395	0.82	0.98	1506	0.95	1.14	1611	1.09	1.31	
	1600 (2720)	1040	0.53	0.64	1168	0.68	0.82	1289	0.76	0.91	1404	0.89	1.07	1514	1.02	1.22	1618	1.17	1.40	
1700 (2890)	1075	0.61	0.73	1195	0.72	0.86	1312	0.84	1.01	1423	0.97	1.16	1530	1.11	1.33	1632	1.26	1.51		
1 hp	1800 (3060)	1109	0.70	0.84	1224	0.81	0.97	1336	0.93	1.12	1443	1.07	1.28	1546	1.21	1.45	1646	1.36	1.63	2 hp
	1900 (3230)	1143	0.79	0.95	1253	0.90	1.08	1360	1.03	1.24	1464	1.17	1.40	1564	1.32	1.58	1661	1.47	1.76	
1.5 hp	2000 (3400)	1177	0.89	1.07	1282	1.01	1.21	1385	1.14	1.37	1485	1.28	1.54	1582	1.43	1.72	1676	1.59	1.91	3 hp
	2100 (3570)	1214	1.01	1.21	1315	1.13	1.36	1414	1.26	1.50	1510	1.40	1.68	1604	1.56	1.87	1695	1.72	2.06	
	2200 (3740)	1248	1.13	1.36	1345	1.25	1.50	1440	1.39	1.70	1533	1.53	1.84	1624	1.68	2.02	1712	1.85	2.22	
	2250 (3825)	1268	1.19	1.43	1364	1.32	1.58	1456	1.46	1.75	1547	1.60	1.92	1637	1.76	2.11	1724	1.92	2.30	

NOTES:

hp = bhp x 1.2

Internal static pressure will vary based on selected options.

Motor selections do not apply to EC Motors.

EC Motors

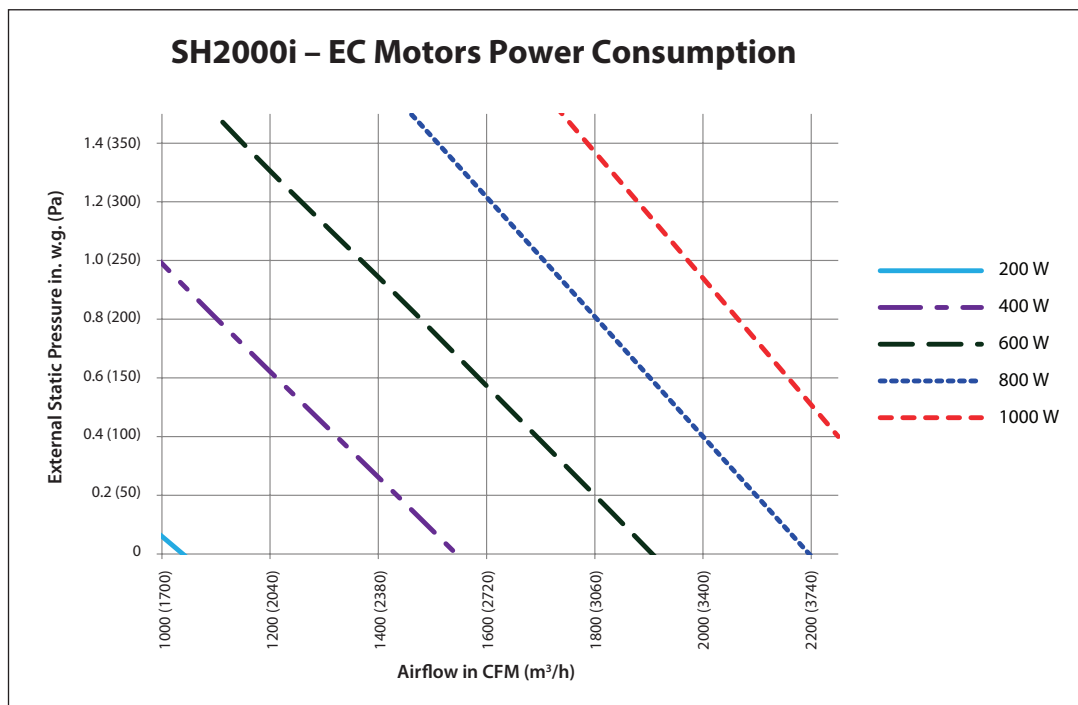

Additional Air Pressure Drop with MERV 13 Filters

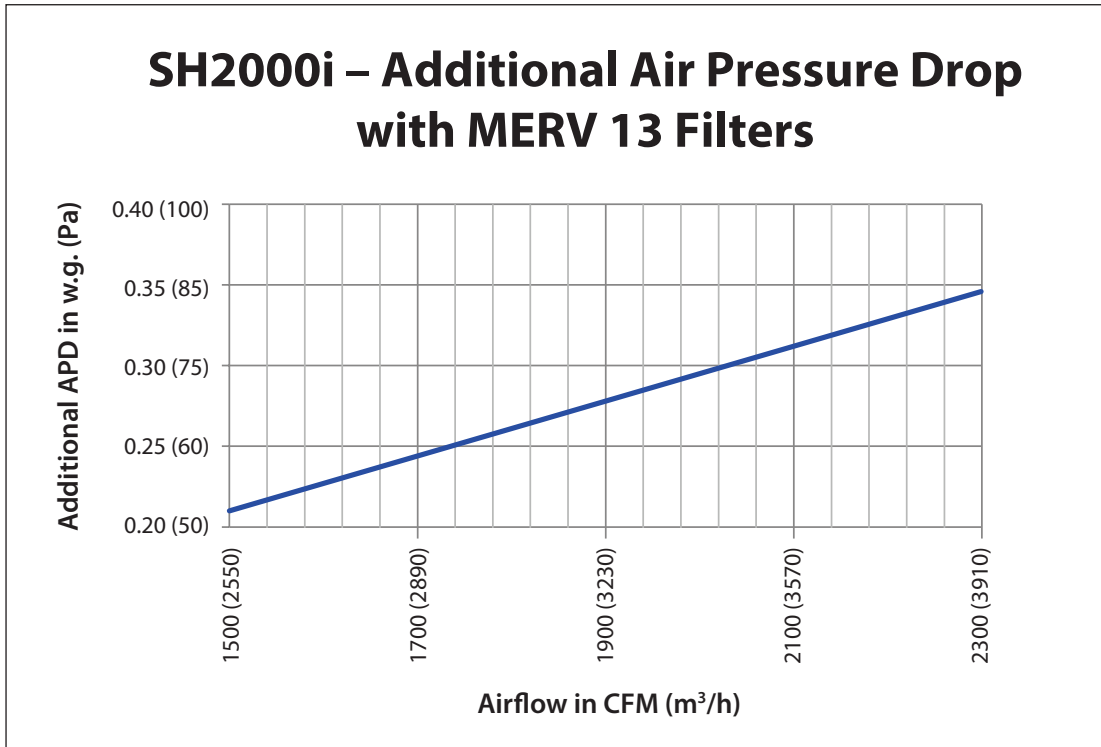

Selection Information

▲ = Standard Feature

☐ = Optional Feature (check the box to select this option)

Send your completed selection to your American ALDES Representative.

MODEL

Series: Standard Commercial (SH)
Nominal Capacity: 1000-2000 CFM
Application: Interior (i)

CASING & CORE

Cabinet Finish

- Galvanized
- Painted
- Pool Construction

Duct Configuration (see pg. 4)

- 1-2-5-6
- 1-3-5-6
- 1-2-4-6
- 1-3-4-6

Mirror Image Cabinet

- Optional

Access Doors

- Fixed/Hinged
- Removable Panels

Plate Exchanger

- Polypropylene
- Aluminum

FILTERS (SUPPLY)

- MERV 8
- MERV 13

BLOWERS & MOTORS ¹

Supply Blower

- 3/4 hp
- 1 hp
- 1.5 hp
- 2 hp
- 3 hp

Exhaust Blower

- 3/4 hp
- 1 hp
- 1.5 hp
- 2 hp
- 3 hp

Motor Type

- ODP
- TEFC
- EC Motors

Speed

- Single Speed
- 2-Speed
- 2-Speed VFD
- Variable Speed Motor
- Variable Speed VFD

ELECTRICAL REQUIREMENTS ¹

- 120V/1ph/60Hz
- 208V/1ph/60Hz
- 230V/1ph/60Hz
- 208V/3ph/60Hz
- 230V/3ph/60Hz
- 460V/3ph/60Hz
- 575V/3ph/60Hz

DISCONNECT

- Non-Fused
- Fused

FROST CONTROL

- None
- Exhaust Defrost ²
- Recirculation ²
- Pre-Heat (Electric Coil)
- Pre-Heat (Hot Water Coil)

HEATING OPTIONS

- None
- Post-Heat (Electric Coil)
- Post-Heat (Hot Water Coil)

ADD-ONS

- Motorized & Insulated Damper for OA ²
- Motorized & Insulated Damper for EA
- Non-Insulated Backdraft Damper for EA
- 24 VAC, 10 VA terminals for OA and/or EA dampers by others
- 24 VAC, 20 VA power available for accessories by others
- Spare Filters QTY: _____
- Spare Belts QTY: _____

¹ See pg. 2 for motor and blower restrictions.

² OA Motorized & Insulated Damper included

Project:		Architect:	
Location:		Engineer:	
Model #:		Contractor:	
Quantity:		Comments:	
Submitted By:			
Date:			