



LOW-PROFILE COMMERCIAL  
**LE2000e**  
Energy Recovery Ventilator

PRODUCT  
SPECIFICATIONS  
& TECHNICAL  
DATA

## Standard Features



### NOMINAL CAPACITY

1000-2500 CFM

### CASING

Double-wall cabinet  
22-gauge galvanized steel interior and exterior  
Supply and exhaust hoods with bird screens  
Motorized and insulated damper on fresh air intake (OA)  
Access doors with quarter-turn handles  
18-gauge galvanized steel drain pan  
Drain Connections: 1" NPT  
Insulation: 2" (51 mm)

### MOUNTING

On 18-gauge galvanized steel roof curb (insulation optional)

### PLATE EXCHANGER

Material: Enthalpy  
Quantity: 3  
Pitch: 0.13" (3.3 mm)  
Dimensions: 16.34" x 16.34" x 15.67"  
(415 mm x 415 mm x 398 mm)



### BLOWERS

Quantity: 2

- Forward-curved
- Permanently sealed and lubricated ball bearings
- Power transmission by adjustable pulleys and belts

### MOTORS

Quantity: 2

- Type: Inverter duty 10:1, ODP or TEFC, EAct or Premium
- Maximum Power: 3 hp
- Drive Assembly/Blower: On vibration-isolating rubber

### FILTERS

Quantity: 2 per circuit

- Type: MERV 8
- Dimensions: 12" x 24" x 4" (305 mm x 610 mm x 102 mm)

### ELECTRICAL & CONTROLS

- Start/stop dry contact and general alarm dry contact
- Occupancy control dry contact
- Fan interlock dry contact
- 24VAC, 20VA power available for accessories
- Access panel to control panel with non-fused disconnect (NEMA 4)
- Single-point power connection
- 120, 208, 230 V / 1ph / 60Hz
- 208, 230, 460, 575 V / 3ph / 60Hz

### WARRANTY

- Core: Limited 10-year warranty
- All Other Covered Components: Limited 2-year warranty

### LISTED BY



# Optional Features

## CABINET

- Painted white baked enamel outside finish
- Pool Construction: TEFC motors, stainless steel interior, and epoxy-coated fans (NOTE: ERV not recommended for indoor pool applications)
- Vibration-isolating springs under blowers
- Motorized and insulated damper for exhaust port (EA)
- Non-insulated backdraft damper for exhaust port (EA)
- 18-gauge stainless steel drain pan
- MERV 13 filters (for supply air circuit only)

## MOTORS & BLOWERS

- TEFC motors (premium available with  $\geq 1.5$  hp/3ph)
- 2-speed motors (only available with ODP, EPAct motors)
- Programmable 2-Speed (VFD)
- Variable Frequency Drive (VFD): 0-10VDC external signal

## FROST CONTROL

Frost control activated by a temperature reference: 14°F (-10°C)

- Internal Pre-Heat by Electric Coil: Powered by unit, factory calibrated, SCR control (unavailable with 120 V)
- Internal Pre-Heat by Hot Water Coil: 0-10 V signal on the control panel
- Exhaust Defrost Cycles: Supply air blower shuts down and outside air damper closes. Warm exhaust air defrosts the core for a predetermined amount of time.
- Recirculation Defrost Cycles: Exhaust air blower shuts down, outside air damper closes, exhaust air damper (optional) closes, and recirculation damper (included) opens. Exhaust air warms up the core for a predetermined amount of time.

## POST-HEAT COILS

- Post-Heat by Electric Coil: Powered by unit, SCR Control, external 0-10VDC control signal
- Post-Heat by Water Coil: External 0-10VDC control signal
- Contact Aldes for Coil Sizing

## CONTROLS

- Low Temperature Limit: Unit will stop if fresh air supply is under set point (adjustable)
- Dirty Filters Contact: Will close a dry contact when dirty filters are detected
- Low Airflow Switch: Will open a dry contact when no airflow is detected on supply blower
- Phase Loss Detection: Unit will stop when a phase loss occurs, automatic restart (3-phase power only)
- Damper End Switch: Unit start up conditional to dampers opening
- Recirculation Dry Contact: For unoccupied mode, must select recirculation defrost option
- Programmable Timer
- BacNet Compatible Controller
  - Available Upgrades:
    - » IP Communication Network Module
    - » MS/TP Communication Network Module
    - » Remote Keypad
    - » Remote Keypad with Touchscreen

MAXIMUM kW PER ELECTRIC COIL	
120V/1ph/60Hz	--
208V/1ph/60Hz	37 kW
230V/1ph/60Hz	43 kW
208V/3ph/60Hz	54 kW
230V/3ph/60Hz	54 kW
460V/3ph/60Hz	54 kW
575V/3ph/60Hz	54 kW

MAXIMUM MBH PER HOT WATER COIL: 98 MBH

# Dimensions

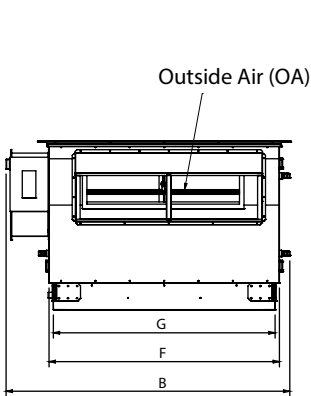
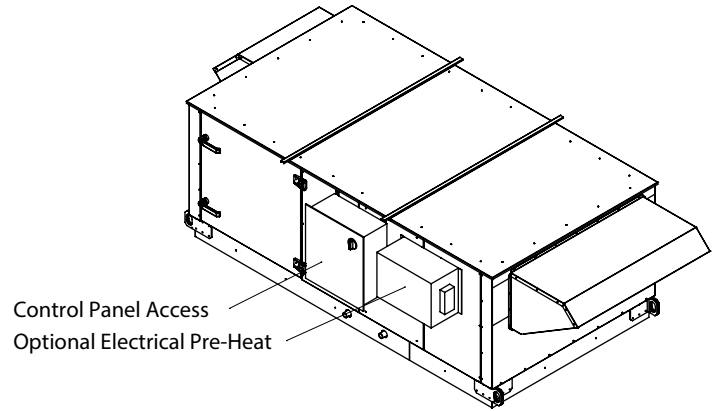
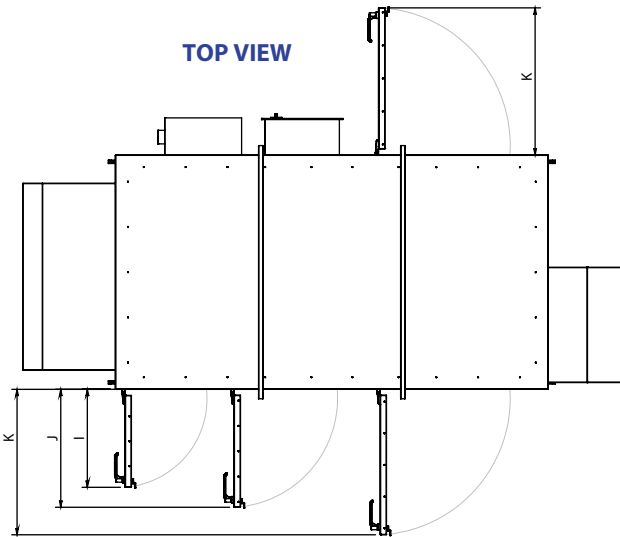

**LEFT VIEW**

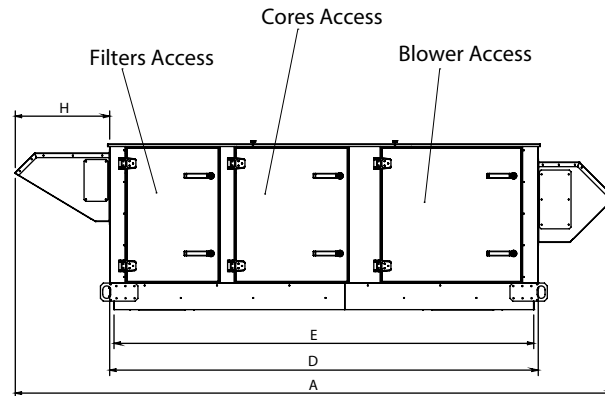

**FRONT VIEW**

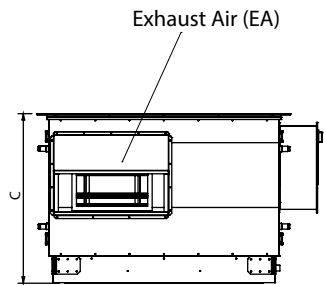

**RIGHT VIEW**

DIMENSIONS*											
Unit	Overall			Details					Doors		
	A	B	C	D	E	F	G	H	I	J	K
Standard	132.88 (3375)	65 (1651)	37.63 (956)	94.75 (2407)	92.85 (2358)	51 (1295)	49 (1245)	20.75 (527)	22 (559)	27 (686)	33 (838)
Post-Heat Option	152.88 (3883)	65 (1651)	42.63 (1083)	114.75 (2915)	112.85 (2866)	51 (1295)	49 (1245)	20.75 (527)	22 (559)	27 (686)	35 (838)

\*All dimensions in inches (mm)

# Configurations & Weights

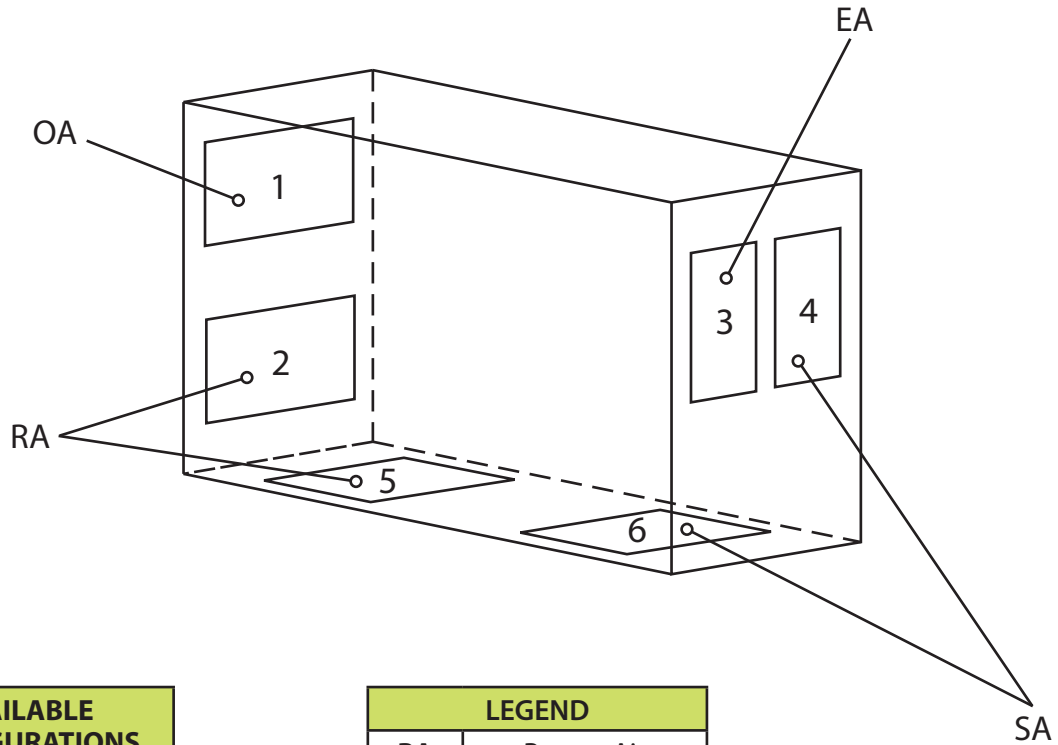

AVAILABLE CONFIGURATIONS
1-3-4-5
1-3-5-6

LEGEND	
RA	Return Air
SA	Supply Air
OA	Outside Air
EA	Exhaust Air

Mirror Image Cabinet Also Available

WEIGHT - LE2000e †	
Unit Weight (Minimum)	1098 lb (498 kg)
Unit Weight (Maximum)	1441 lb (654 kg)
Shipping Weight (Minimum)	1213 lb (550 kg)
Shipping Weight (Maximum)	1556 lb (706 kg)

† Actual weight may vary by ±10%. Roof curb shipped separately.

# Roof Curb Dimensions

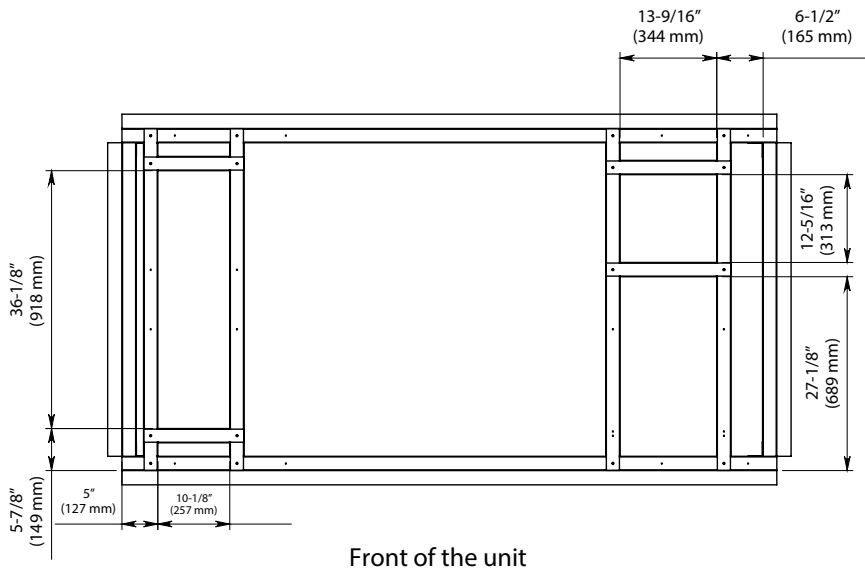
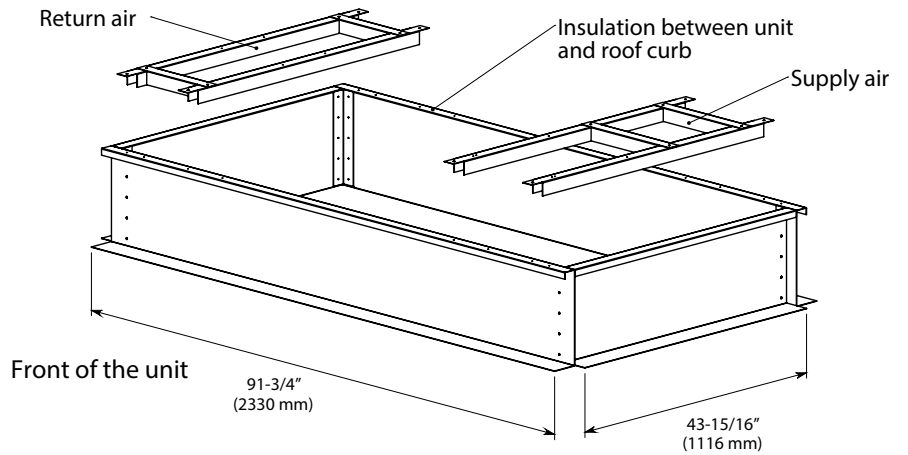

**NOTE: Drawings not to scale**

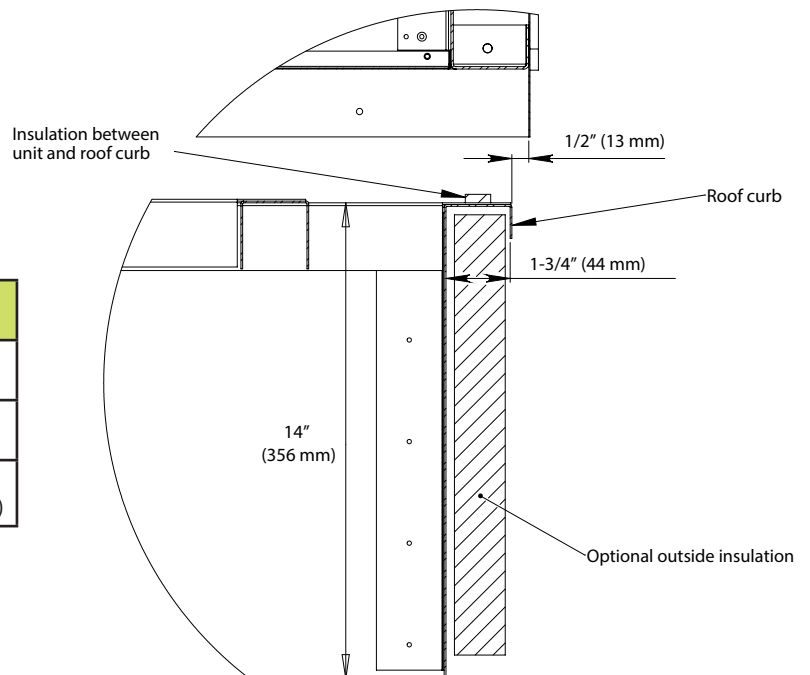

ROOF CURB WEIGHTS & DIMENSIONS	
Roof Curb Weight	105 lb (48 kg)
Shipping Weight	150 lb (60 kg)
Shipping Dimensions (W x H x D)	96" x 24" x 25" (2438 mm x 610 mm x 635 mm)

# Enthalpy Core Performance

AHRI STANDARD CONDITIONS	CONDITIONS	
Outside Air Temperature	Winter	Summer
Dry Bulb	35°F (1.7°C)	95°F (35°C)
Wet Bulb	33°F (0.6°C)	78°F (25.6°C)
Exhaust Air Temperature	Winter	Summer
Dry Bulb	70°F (21.1°C)	75°F (23.9°C)
Wet Bulb	58°F (14.4°C)	63°F (17.2°C)

Note: Efficiencies are based on AHRI standard winter conditions.

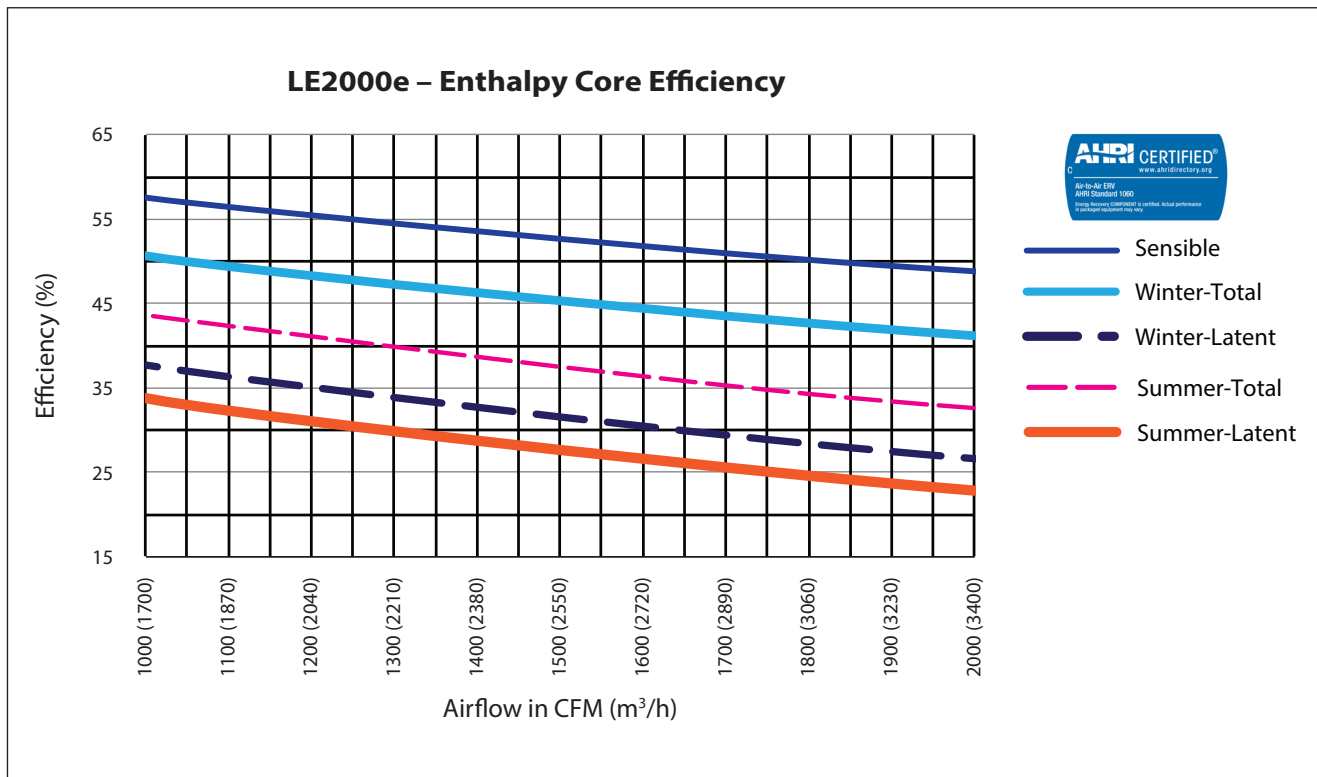

## Motor Selection – Enthalpy Core

SUPPLY/EXHAUST																					
MOTOR	AIRFLOW	EXTERNAL STATIC PRESSURE (in H <sub>2</sub> O) - SUPPLY/EXHAUST																		MOTOR	
		0.25 (60 Pa)			0.50 (125 Pa)			0.75 (185 Pa)			1.00 (250 Pa)			1.25 (310 Pa)			1.50 (375 Pa)				
		CFM (m <sup>3</sup> /h)	RPM	BHP	HP	RPM	BHP	HP	RPM	BHP	HP	RPM	BHP	HP	RPM	BHP	HP	RPM	BHP		HP
3/4 hp	1000 (1700)	886	0.26	0.31	992	0.33	0.40	1086	0.40	0.48	1169	0.48	0.58	1243	0.55	0.66	1312	0.63	0.76	1 hp	
	1100 (1870)	901	0.30	0.36	1005	0.37	0.45	1098	0.45	0.53	1182	0.53	0.64	1258	0.61	0.73	1328	0.69	0.83		
	1200 (2040)	916	0.34	0.41	1018	0.42	0.50	1111	0.50	0.59	1195	0.58	0.70	1271	0.66	0.80	1343	0.75	0.91		
	1300 (2210)	932	0.38	0.46	1032	0.46	0.56	1123	0.55	0.66	1207	0.64	0.77	1285	0.73	0.87	1357	0.82	0.99		
	1400 (2380)	947	0.43	0.52	1045	0.52	0.62	1135	0.61	0.73	1219	0.70	0.84	1297	0.79	0.95	1371	0.89	1.07		1.5 hp
	1500 (2550)	963	0.49	0.59	1058	0.57	0.69	1148	0.67	0.80	1231	0.77	0.92	1309	0.86	1.04	1383	0.97	1.16		
	1600 (2720)	978	0.55	0.66	1072	0.64	0.76	1160	0.73	0.88	1242	0.83	1.00	1321	0.94	1.13	1395	1.05	1.26		
	1700 (2890)	994	0.61	0.73	1086	0.70	0.84	1172	0.81	0.97	1253	0.91	1.09	1332	1.02	1.22	1405	1.13	1.36		
1 hp	1800 (3060)	1010	0.68	0.81	1099	0.77	0.93	1184	0.88	1.06	1264	0.99	1.18	1342	1.10	1.32	1415	1.22	1.46	2 hp	
	1900 (3230)	1026	0.75	0.90	1113	0.85	1.02	1196	0.96	1.15	1275	1.07	1.28	1362	1.19	1.42	1424	1.31	1.57		
	2000 (3400)	1042	0.82	0.99	1127	0.93	1.11	1208	1.04	1.25	1285	1.15	1.39	1361	1.28	1.53	1432	1.40	1.68		
1.5 hp	2100 (3570)	1058	0.90	1.08	1140	1.01	1.21	1219	1.13	1.35	1295	1.24	1.49	1369	1.37	1.64	1439	1.40	1.80	3 hp	
	2200 (3740)	1075	0.98	1.18	1154	1.10	1.32	1231	1.22	1.46	1305	1.34	1.61	1377	1.47	1.76	1445	1.60	1.92		
	2300 (3910)	1091	1.07	1.29	1168	1.19	1.43	1243	1.32	1.58	1314	1.44	1.73	1384	1.57	1.89	1451	1.71	2.05		
	2400 (4080)	1108	1.16	1.40	1182	1.29	1.54	1254	1.42	1.70	1324	1.54	1.85	1391	1.68	2.01	1455	1.82	2.18		
2 hp	2500 (4250)	1124	1.26	1.51	1196	1.39	1.67	1266	1.52	1.82	1333	1.65	1.98	1397	1.79	2.15	1459	1.93	2.32		

### NOTES:

hp = bhp x 1.2

Contact Aldes for Additional Pressure Drop (APD) with Hot Water or Electric Coils

## Additional Air Pressure Drop with MERV 13 Filters

Airflow CFM (m <sup>3</sup> /h)	APD inH <sub>2</sub> O (Pa)
1000 (1700)	0.02 (4)
1100 (1870)	0.02 (4)
1200 (2040)	0.02 (4)
1300 (2210)	0.03 (6)
1400 (2380)	0.03 (6)
1500 (2550)	0.03 (6)
1600 (2720)	0.03 (6)
1700 (2890)	0.04 (7)

Airflow CFM (m <sup>3</sup> /h)	APD inH <sub>2</sub> O (Pa)
1800 (3060)	0.04 (7)
1900 (3230)	0.04 (7)
2000 (3400)	0.05 (11)
2100 (3570)	0.05 (11)
2200 (3740)	0.05 (11)
2300 (3910)	0.06 (12)
2400 (4080)	0.06 (12)
2500 (4250)	0.06 (12)

# Selection Information

▲ = Standard Feature

☐ = Optional Feature (check the box to select this option)

Send your completed selection to your American ALDES Representative.

## MODEL

**Series:** Low-Profile Commercial (LE)

**Nominal Capacity:** 1000-2500 CFM

**Application:** Exterior (e)

## CASING

### Cabinet Finish

- Galvanized
- Painted
- Pool Construction

### Duct Configuration (see pg. 4)

- 1-3-5-6
- 1-3-4-5

### Mirror Image Cabinet

- Optional

### Roof Curb

- Insulated
- Non-Insulated

### Drain Pan

- Galvanized
- Stainless Steel

## FROST CONTROL

- None
- Exhaust Defrost
- Recirculation
- Pre-Heat (Electric Coil)
- Pre-Heat (Hot Water Coil)

## POST-HEAT COILS

- Electric Coil
- Hot Water Coil

## FILTERS (SUPPLY)

- MERV 8
- MERV 13

## BLOWERS & MOTORS

### Supply Blower

- 3/4 hp
- 1 hp
- 1.5 hp
- 2 hp
- 3 hp

### Exhaust Blower

- 3/4 hp
- 1 hp
- 1.5 hp
- 2 hp
- 3 hp

### Motor Type

- ODP, EPA<sup>1</sup>
- ODP, Premium<sup>2</sup>
- TEFC, EPA<sup>1</sup>
- TEFC, Premium<sup>3</sup>

### Blower Control

- Single Speed
- 2-Speed<sup>4</sup>
- Programmable 2-Speed (VFD)
- VFD

### Drive Assembly/Blower

- On vibration-isolating rubber
- On vibration-isolating springs

## ELECTRICAL REQUIREMENTS

- 120V/1ph/60Hz
- 208V/1ph/60Hz
- 230V/1ph/60Hz
- 208V/3ph/60Hz
- 230V/3ph/60Hz
- 460V/3ph/60Hz
- 575V/3ph/60Hz

## ADD-ONS

- Motorized & Insulated Damper for EA
- Non-Insulated Backdraft Damper for EA
- Low Temperature Limit
- Dirty Filters Contact
- Low Airflow Switch
- Phase Loss Detection
- Damper End Switch
- Recirculation Dry Contact<sup>5</sup>
- Programmable Timer
- BacNet Compatible Controller
  - With IP Module
  - With MS/TP Module
  - With Remote Keypad
  - With Remote Keypad (Touchscreen)
- Spare MERV 8 Filters QTY: \_\_\_\_\_
- Spare Belts QTY: \_\_\_\_\_

<sup>1</sup> EPA<sup>1</sup> efficiency only available when Premium efficiency is not available (e.g., with single-phase motors)

<sup>2</sup> ODP, Premium only available with ≥3 hp/ 3ph motors

<sup>3</sup> TEFC, Premium only available with ≥1.5 hp/ 3ph motors

<sup>4</sup> 2-Speed only available with ODP, EPA<sup>1</sup> motors

<sup>5</sup> Recirculation Dry Contact requires selection of recirculation defrost

<b>Project:</b>		<b>Architect:</b>	
<b>Location:</b>		<b>Engineer:</b>	
<b>Model #:</b>		<b>Contractor:</b>	
<b>Quantity:</b>		<b>Comments:</b>	
<b>Submitted By:</b>			
<b>Date:</b>			