



## AEROMATIC™ SERIES STANDARD COMMERCIAL

# SH4000i

## Heat Recovery Ventilator

PRODUCT  
SPECIFICATIONS  
& TECHNICAL  
DATA



### NOMINAL CAPACITY

3000-4000 CFM

### CASING – STANDARD

- Double-wall cabinet
- 22-gauge galvanized steel interior and exterior
- Access doors with quarter-turn handles
- 22-gauge galvanized steel drain pan
- Drain Connections: 1" NPT
- Insulation: 1" (25 mm)

### CASING – OPTIONAL

- Painted white baked enamel outside finish
- Pool Construction: TEFC motors, stainless steel interior, and epoxy-coated fans
- Removable access panels

### MOUNTING – STANDARD

On platform

### PLATE EXCHANGER OPTIONS

Polypropylene (sensible heat transfer)

Quantity: 4

Pitch: 0.16" (4 mm)

Dimensions: 21" x 21" x 19-3/8"

(533 mm x 533 mm x 492 mm)



Aluminum (sensible heat transfer)

Quantity: 4

Pitch: 0.17" (4.2 mm)

Dimensions: 19-3/8" x 19-3/8" x 19-3/8"

(492 mm x 492 mm x 492 mm)



### BLOWERS & MOTORS – STANDARD OPTIONS

Blowers:

- Quantity: 2
- Forward-curved
- Permanently sealed and lubricated ball bearings
- Power transmission by adjustable pulleys and belts

Motors:

- Type: Inverter duty 10:1
- Maximum Power: 5 hp
- Available Voltage:
  - » 120, 208, 230 V / 1ph / 60Hz
  - » 208, 230, 460, 575 V / 3ph / 60Hz

(See table on page 2 for details)

### EC MOTORS – OPTIONAL

Blowers:

- Quantity: 4 (2 per air stream)
- Plenum Type: Backward Inclined
- Permanently sealed and lubricated ball bearings
- Direct Drive

EC Motors:

- Maximum Power:
  - » 1.9 kW at 208-230 V / 3ph / 60Hz
  - » 2.5 kW at 460 V / 3ph / 60Hz
- Available Voltage:
  - » 208, 230, 460 V / 3ph / 60Hz

(See table on page 2 for details)

### ELECTRICAL & CONTROLS – STANDARD

- 24 V double motor contactor with start-stop dry contact
- Non-fused disconnect (NEMA 4)
- 24 V transformer for controls

### ELECTRICAL & CONTROLS – OPTIONAL

- Fused disconnect
- 24 VAC, 20 VA power available for accessories

### FILTERS – STANDARD

Quantity: 4 supply, 4 exhaust

Type: MERV 8

Dimensions: 18" x 20" x 2" (457 mm x 508 mm x 51 mm)

### FILTERS – OPTIONAL

MERV 13 Filters (substitute on supply air circuit only)

### LISTED BY



Intertek

# SH4000i Features (Continued)

## FROST PREVENTION/CONTROL – OPTIONS

If no defrost mode is selected, it is the customer's responsibility to protect the core from freezing.

Frost control activated by a temperature reference: 23°F (-5°C)

Internal Pre-Heat by Electric Coil:

- Powered by unit, SCR control (unavailable with 120 V)

Internal Pre-Heat by Hot Water Coil:

- 0-10 V signal on the control panel
- Piping connections under unit

Exhaust Defrost:

- Supply air blower shuts down and outside air damper closes. Warm exhaust air defrosts the core until it is completely defrosted.
- Includes motorized and insulated damper on fresh air intake (OA)

Recirculation Defrost:

- Exhaust air blower shuts down, outside air damper closes, exhaust air damper (optional) closes, and recirculation damper (included) opens. Exhaust air warms up the core for a predetermined amount of time (see table at right).
- Includes motorized and insulated damper on fresh air intake (OA)

## POST-HEAT COILS

Post-Heat by Electric Coil:

- Powered by unit, SCR control (unavailable with 120 V)

Post-Heat by Hot Water Coil:

- 0-10VDC signal to maintain supply air temperature, or 0-10VDC signal by others

## OPTIONAL COMPONENTS

- Motorized and insulated damper for exhaust port (EA)
  - » Adds 7" (178 mm) to overall unit width
- Non-insulated backdraft damper for exhaust port (EA)
- Motorized and insulated damper on fresh air intake (OA) (included with exhaust defrost and recirculation)

## WARRANTY

- Core Assembly: Limited 10-year
- All Other Covered Components: Limited 2-year

RECIRCULATION DEFROST CYCLE TEMPERATURE			
Outside Temperature		Minutes Defrost/Vent	
°F	°C	Standard	Extended
t > 23	t > -5	N/A	N/A
23 > t > -13	-5 > t > -25	7/25	10/20
-13 > t	-25 > t	10/22	10/15

# SH4000i Motor & Blower Options\*

		PARAMETERS																	
		HP					VOLTAGE & PHASE								MOTOR SPEED				
		3/4	1	1.5	2	3	5	1-PHASE			3-PHASE				SINGLE SPEED	2-SPEED		VARIABLE SPEED	
								120 V	208 V	230 V	208 V	230 V	460 V	575 V		MOTOR	VFD	MOTOR	VFD
MOTOR TYPE & EFFICIENCY†	ODP, EPAct	✓	✓	✓	✓		✓	✓	✓					✓	✓	✓		✓	
	ODP, Premium					✓	✓			✓	✓	✓	✓	✓		✓		✓	
	TEFC, EPAct	✓	✓					✓	✓	✓					✓		✓		✓
	TEFC, Premium			✓	✓	✓	✓				✓	✓	✓	✓	✓		✓		✓
	EC Motors	N/A								✓	✓	✓		✓	✓			✓	

\*See pages 7-8 for motor sizing. See page 8 for EC Motors Power Consumption.

†Premium efficiency required when available.

# SH4000i Dimensions

Keep a minimum distance of 42" (1067 mm) in front of the unit and 24" (610 mm) behind it

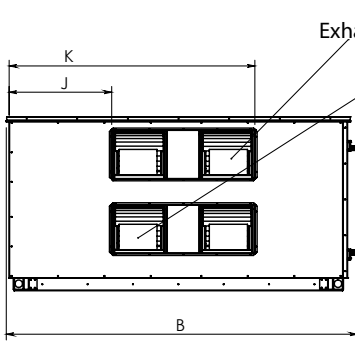
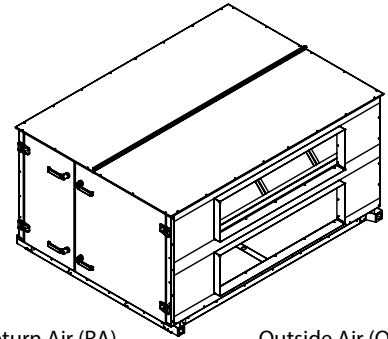
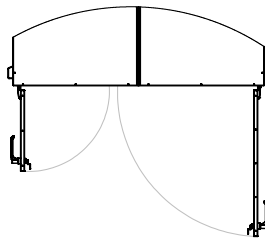

**LEFT VIEW**

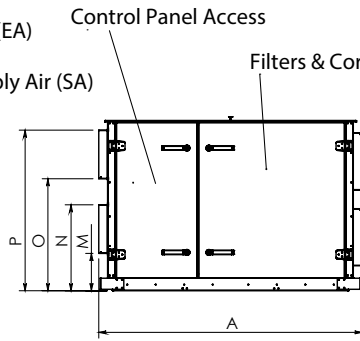

**FRONT VIEW**

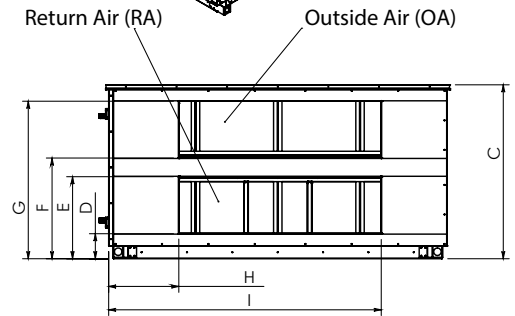

**RIGHT VIEW**

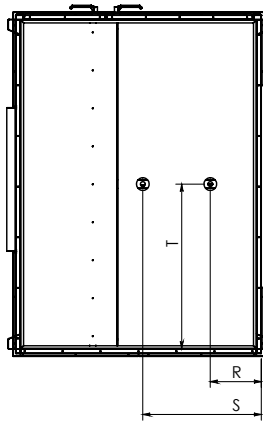

**BOTTOM VIEW**

DIMENSIONS in inches (mm)										
Overall			Openings							
A**			B	C	D	E	F	G	H	
Standard	1 Extension	2 Extensions								
66 (1676)	86 (2184)	106 (2692)	84.75 (2153)	46.75 (1187)	7.75 (197)	21.25 (540)	27.75 (705)	41.25 (1048)	16.625 (422)	
Openings										
I	J	K	M	N	O	P	Q	R	S	T
64.625 (1641)	24.25 (616)	58.25 (1480)	8.5 (216)	20 (508)	27.75 (705)	39.25 (997)	2 (51)	12.125 (308)	28.125 (714)	40.25 (1022)

\*Optional motorized and insulated damper for exhaust port (EA) adds 7" (178 mm) to overall unit width

# SH4000i Configurations & Weights

AVAILABLE CONFIGURATIONS*
1-2-5-6
1-3-5-6
1-2-4-6
1-3-4-6

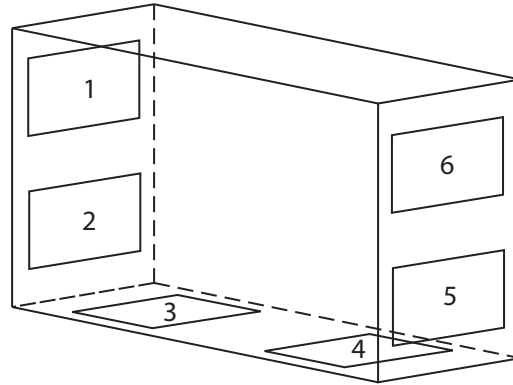

DUCT CONNECTION KEY	
1	Exhaust Air (EA)
2, 3	Supply Air (SA)
4, 5	Return Air (RA)
6	Outside Air (OA)

\*Mirror Image Cabinet Also Available

SH4000i WEIGHTS & DIMENSIONS †	
Minimum Unit Weight	895 lbs (406 kg)
Maximum Unit Weight	1820 lbs (826 kg)
Minimum Shipping Weight	940 lbs (426 kg)
Maximum Shipping Weight	1865 lbs (846 kg)

† Actual weight may vary by ±10%.

# Polypropylene Core Performance

AHRI STANDARD CONDITIONS	CONDITIONS	
Outside Air Temperature	Winter	Summer
Dry Bulb	35°F (1.7°C)	95°F (35°C)
Wet Bulb	33°F (0.6°C)	78°F (25.6°C)
Exhaust Air Temperature	Winter	Summer
Dry Bulb	70°F (21.1°C)	75°F (23.9°C)
Wet Bulb	58°F (14.4°C)	63°F (17.2°C)

Note: Efficiencies are based on AHRI standard conditions.

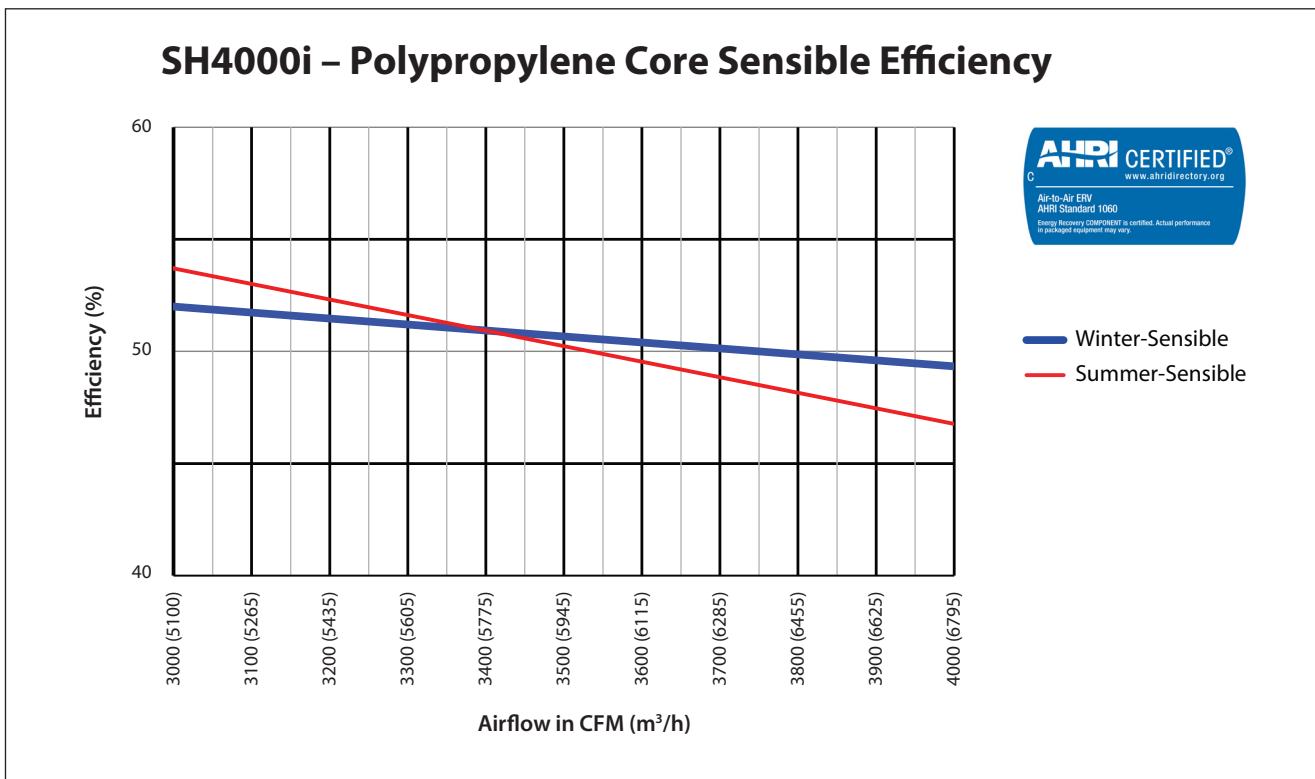

# Aluminum Core Performance

AHRI STANDARD CONDITIONS	CONDITIONS	
Outside Air Temperature	Winter	Summer
Dry Bulb	35°F (1.7°C)	95°F (35°C)
Wet Bulb	33°F (0.6°C)	78°F (25.6°C)
Exhaust Air Temperature	Winter	Summer
Dry Bulb	70°F (21.1°C)	75°F (23.9°C)
Wet Bulb	58°F (14.4°C)	63°F (17.2°C)

Note: Efficiencies are based on AHRI standard conditions.

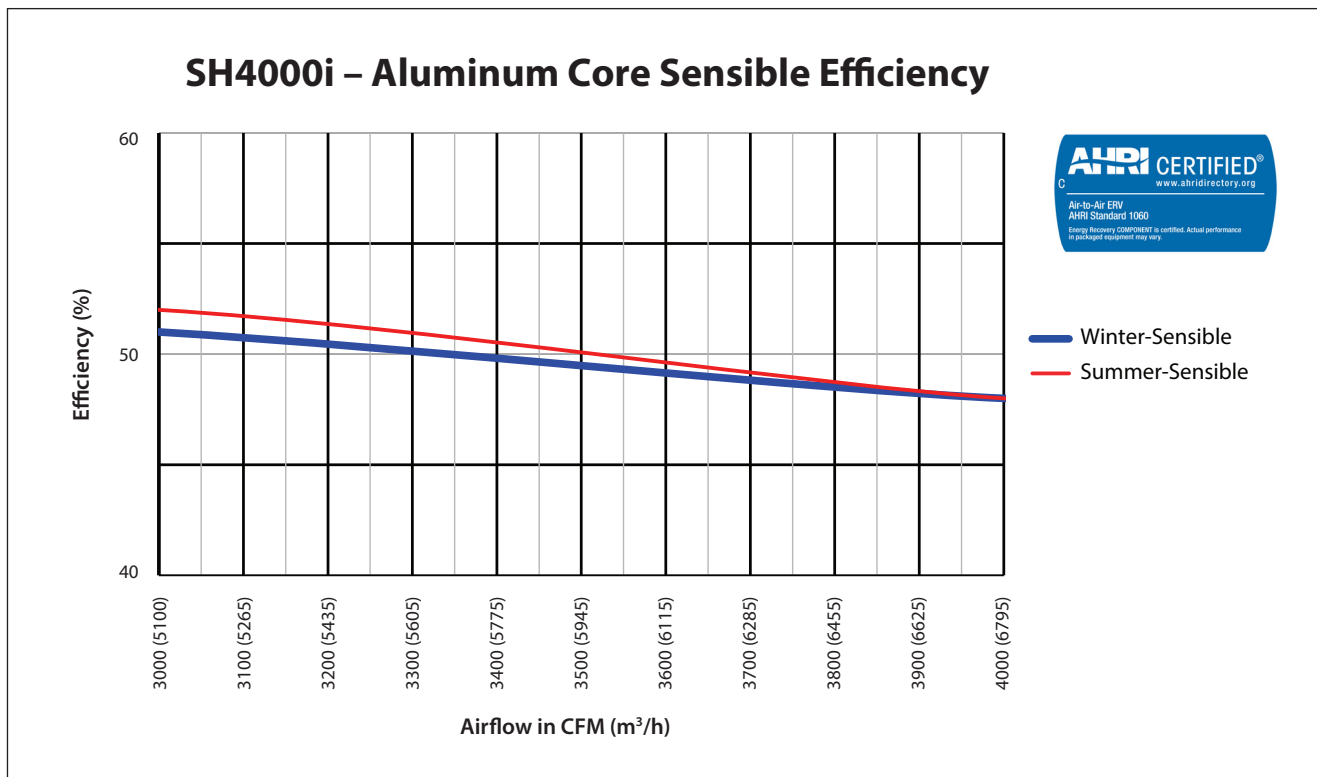

# Motor Selection – Polypropylene Core

SUPPLY																				
MOTOR	CFM (m <sup>3</sup> /h)	EXTERNAL STATIC PRESSURE (inH <sub>2</sub> O) - SUPPLY																		MOTOR
		0.25 (60 Pa)			0.50 (125 Pa)			0.75 (185 Pa)			1.00 (250 Pa)			1.25 (310 Pa)			1.50 (375 Pa)			
		RPM	BHP	HP	RPM	BHP	HP	RPM	BHP	HP	RPM	BHP	HP	RPM	BHP	HP	RPM	BHP	HP	
1.5 hp	3000 (5100)	1066	1.00	1.20	1196	1.22	1.46	1319	1.47	1.76	1436	1.73	2.08	1545	2.00	2.40	1647	2.28	2.74	3 hp
	3100 (5265)	1091	1.09	1.31	1218	1.32	1.58	1339	1.56	1.87	1453	1.83	2.20	1561	2.11	2.53	1662	2.40	2.88	
	3200 (5435)	1112	1.17	1.40	1236	1.40	1.68	1354	1.65	1.98	1467	1.93	2.32	1573	2.21	2.65	1673	2.50	3.00	
2 hp	3300 (5605)	1137	1.27	1.52	1258	1.50	1.80	1372	1.76	2.11	1483	2.03	2.44	1589	2.33	2.80	1688	2.63	3.16	5 hp
	3400 (5775)	1157	1.36	1.63	1275	1.60	1.92	1388	1.86	2.23	1596	2.14	2.57	1600	2.43	2.92	1699	2.74	3.29	
	3500 (5945)	1182	1.46	1.75	1297	1.71	2.05	1407	1.97	2.36	1513	2.26	2.71	1616	2.55	3.06	1713	2.87	3.44	
	3600 (6115)	1206	1.57	1.88	1318	1.82	2.18	1426	2.09	2.51	1530	2.38	2.86	1631	2.68	3.22	1727	3.00	3.60	
3 hp	3700 (6285)	1225	1.68	2.02	1335	1.93	2.32	1441	2.20	2.64	1542	2.49	2.99	1642	2.80	3.36	1737	3.12	3.74	5 hp
	3800 (6455)	1253	1.81	2.17	1360	2.06	2.47	1464	2.34	2.81	1564	2.63	3.16	1661	2.94	3.53	1755	3.27	3.92	
	3900 (6625)	1272	1.92	2.30	1376	2.18	2.62	1478	2.46	2.95	1577	2.76	3.31	1672	3.07	3.68	1765	3.40	4.08	
	4000 (6795)	1299	2.06	2.47	1401	2.32	2.78	1501	2.61	3.13	1597	2.91	3.49	1691	3.23	3.88	1782	3.56	4.27	
	4100 (6965)	1325	2.20	2.64	1425	2.47	2.96	1523	2.76	3.31	1617	3.06	3.67	1709	3.38	4.06	1799	3.72	4.46	
	4200 (7135)	1347	2.34	2.81	1445	2.61	3.13	1541	2.90	3.48	1634	3.21	3.85	1724	3.54	4.25	1812	3.88	4.66	
	4250 (7220)	1356	2.41	2.89	1453	2.68	3.22	1548	2.97	3.56	1640	3.28	3.94	1729	3.61	4.33	1817	3.95	4.74	

EXHAUST																				
MOTOR	CFM (m <sup>3</sup> /h)	EXTERNAL STATIC PRESSURE (inH <sub>2</sub> O) - EXHAUST																		MOTOR
		0.25 (60 Pa)			0.50 (125 Pa)			0.75 (185 Pa)			1.00 (250 Pa)			1.25 (310 Pa)			1.50 (375 Pa)			
		RPM	BHP	HP	RPM	BHP	HP	RPM	BHP	HP	RPM	BHP	HP	RPM	BHP	HP	RPM	BHP	HP	
1 hp	3000 (5100)	894	0.77	0.92	1032	0.95	1.14	1165	1.17	1.40	1290	1.41	1.69	1409	1.66	1.99	1520	1.93	2.32	3 hp
	3100 (5265)	909	0.83	1.00	1044	1.01	1.21	1174	1.23	1.48	1296	1.47	1.76	1413	1.73	2.08	1523	2.01	2.41	
1.5 hp	3200 (5435)	919	0.88	1.06	1051	1.07	1.28	1178	1.29	1.55	1298	1.53	1.84	1413	1.79	2.15	1523	2.07	2.48	3 hp
	3300 (5605)	940	0.96	1.15	1068	1.15	1.38	1192	1.37	1.64	1310	1.61	1.93	1423	1.88	2.26	1531	2.16	2.59	
	3400 (5775)	949	1.02	1.22	1075	1.22	1.46	1195	1.43	1.72	1312	1.68	2.02	1423	1.94	2.33	1530	2.23	2.68	
	3500 (5945)	964	1.09	1.31	1087	1.29	1.55	1205	1.51	1.81	1319	1.76	2.11	1428	2.03	2.44	1534	2.31	2.77	
	3600 (6115)	984	1.17	1.40	1104	1.38	1.66	1219	1.60	1.92	1331	1.85	2.22	1439	2.12	2.54	1542	2.41	2.89	
2 hp	3700 (6285)	994	1.24	1.49	1113	1.46	1.75	1225	1.68	2.02	1335	1.93	2.32	1441	2.20	2.64	1542	2.49	2.99	5 hp
	3800 (6455)	1008	1.31	1.57	1126	1.54	1.85	1236	1.77	2.12	1344	2.02	2.42	1448	2.29	2.75	1548	2.58	3.10	
	3900 (6625)	1024	1.40	1.68	1138	1.63	1.96	1247	1.86	2.23	1352	2.11	2.53	1455	2.39	2.87	1553	2.68	3.22	
	4000 (6795)	1043	1.49	1.79	1155	1.74	2.09	1261	1.97	2.36	1364	2.22	2.66	1465	2.50	3.00	1563	2.80	3.36	
3 hp	4100 (6965)	1053	1.57	1.88	1164	1.82	2.18	1268	2.06	2.47	1369	2.31	2.77	1468	2.59	3.11	1565	2.89	3.47	5 hp
	4200 (7135)	1069	1.67	2.00	1177	1.93	2.32	1279	2.17	2.60	1378	2.42	2.90	1476	2.70	3.24	1571	3.00	3.60	
	4250 (7220)	1076	1.71	2.05	1184	1.98	2.38	1285	2.23	2.68	1383	2.48	2.98	1480	2.76	3.31	1575	3.06	3.67	

## NOTES:

hp = bhp x 1.2

Internal static pressure will vary based on selected options.

Motor selections do not apply to EC Motors.

# Motor Selection – Aluminum Core

SUPPLY/EXHAUST																				
MOTOR	CFM (m <sup>3</sup> /h)	EXTERNAL STATIC PRESSURE (inH <sub>2</sub> O) - SUPPLY/EXHAUST																		MOTOR
		0.25 (60 Pa)			0.50 (125 Pa)			0.75 (185 Pa)			1.00 (250 Pa)			1.25 (310 Pa)			1.50 (375 Pa)			
		RPM	BHP	HP	RPM	BHP	HP	RPM	BHP	HP	RPM	BHP	HP	RPM	BHP	HP	RPM	BHP	HP	
1.5 hp	3000 (5100)	1005	0.91	1.09	1139	1.12	1.34	1265	1.35	1.62	1385	1.61	1.93	1498	1.88	2.26	1603	2.16	2.59	3 hp
	3100 (5265)	1018	0.97	1.16	1148	1.19	1.43	1272	1.42	1.70	1390	1.68	2.02	1502	1.95	2.34	1607	2.23	2.68	
	3200 (5435)	1035	1.05	1.26	1163	1.26	1.51	1284	1.50	1.80	1400	1.76	2.11	1510	2.04	2.45	1614	2.33	2.80	
	3300 (5605)	1058	1.13	1.36	1182	1.35	1.62	1300	1.59	1.91	1414	1.86	2.23	1522	2.14	2.57	1625	2.43	2.92	
	3400 (5775)	1075	1.22	1.46	1195	1.43	1.72	1312	1.68	2.02	1423	1.94	2.33	1530	2.23	2.68	1632	2.53	3.04	
2 hp	3500 (5945)	1097	1.31	1.57	1214	1.53	1.84	1328	1.78	2.14	1437	2.05	2.46	1542	2.34	2.81	1643	2.64	3.17	5 hp
	3600 (6115)	1119	1.41	1.69	1233	1.63	1.96	1345	1.89	2.27	1452	2.16	2.59	1554	2.45	2.94	1654	2.75	3.30	
	3700 (6285)	1136	1.50	1.80	1247	1.73	2.08	1357	1.98	2.38	1462	2.26	2.71	1563	2.55	3.06	1661	2.86	3.43	
	3800 (6455)	1156	1.61	1.93	1266	1.83	2.20	1373	2.09	2.51	1476	2.37	2.84	1575	2.67	3.20	1672	2.98	3.58	
3 hp	3900 (6625)	1173	1.71	2.05	1280	1.94	2.33	1385	2.20	2.64	1487	2.48	2.98	1584	2.78	3.34	1680	3.10	3.72	5 hp
	4000 (6795)	1194	1.82	2.18	1299	2.06	2.47	1401	2.32	2.78	1501	2.61	3.13	1597	2.91	3.49	1691	3.23	3.88	
	4100 (6965)	1214	1.94	2.33	1317	2.18	2.62	1417	2.44	2.93	1515	2.73	3.28	1610	3.04	3.65	1701	3.36	4.03	
	4200 (7135)	1235	2.06	2.47	1335	2.31	2.77	1433	2.57	3.08	1529	2.87	3.44	1623	3.17	3.80	1713	3.50	4.20	
	4250 (7220)	1245	2.13	2.56	1345	2.38	2.86	1442	2.64	3.17	1537	2.93	3.52	1629	3.24	3.89	1719	3.57	4.28	

**NOTES:**

hp = bhp x 1.2

Internal static pressure will vary based on selected options.

Motor selections do not apply to EC Motors.

## EC Motors

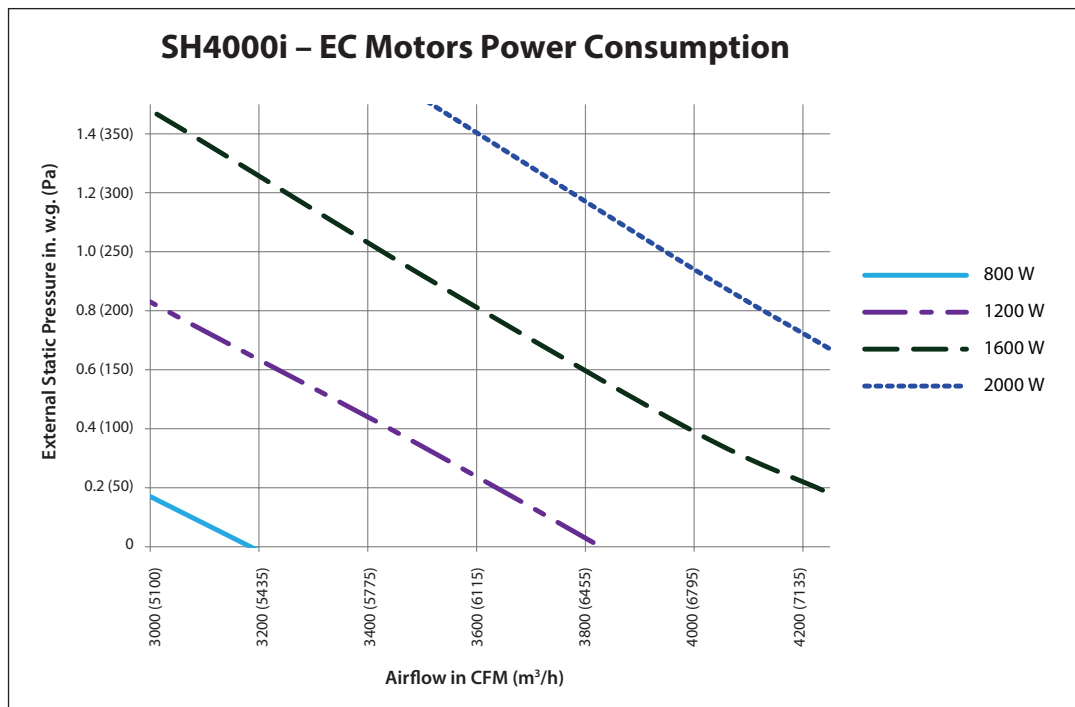



## Additional Air Pressure Drop with MERV 13 Filters

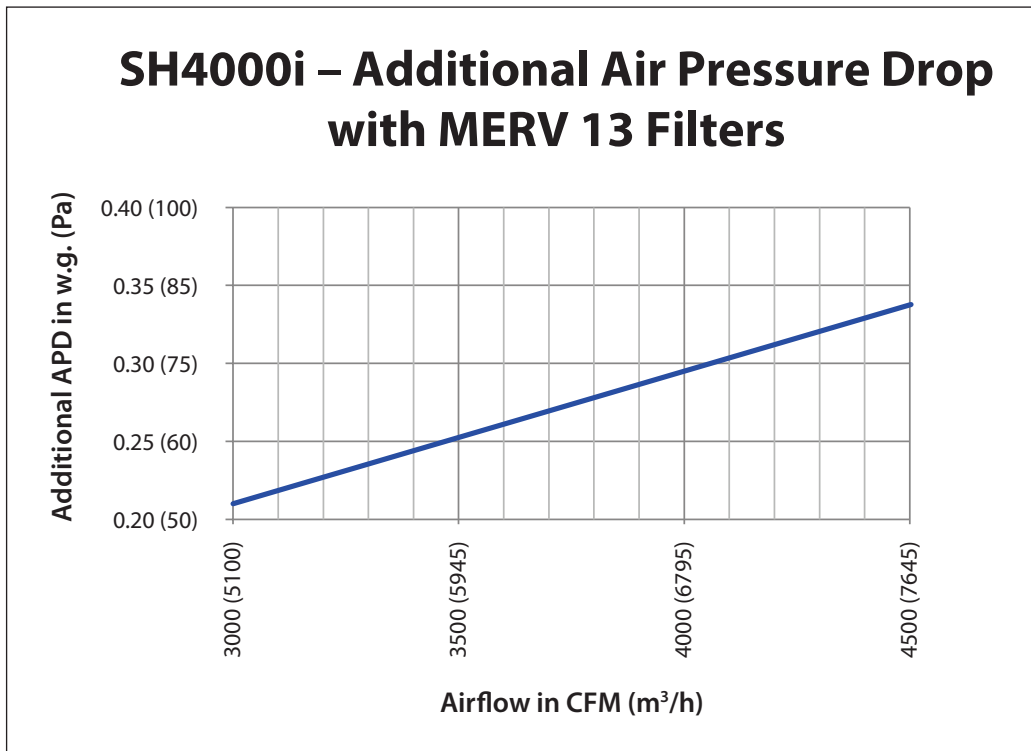

# Selection Information

▲ = Standard Feature

☐ = Optional Feature (check the box to select this option)

Send your completed selection to your Aldes Canada Representative.

## MODEL

Series: Standard Commercial (SH)  
 Nominal Capacity: 3000-4000 CFM  
 Application: Interior (i)

## CASING & CORE

### Cabinet Finish

- Galvanized
- Painted
- Pool Construction

### Duct Configuration (see pg. 4)

- 1-2-5-6
- 1-3-5-6
- 1-2-4-6
- 1-3-4-6

### Mirror Image Cabinet

- Optional

### Access Doors

- Fixed/Hinged
- Removable Panels

### Plate Exchanger

- Polypropylene
- Aluminum

## FILTERS (SUPPLY)

- MERV 8
- MERV 13

## BLOWERS & MOTORS <sup>1</sup>

### Supply Blower

- 3/4 hp
- 1 hp
- 1.5 hp
- 2 hp
- 3 hp
- 5 hp

### Exhaust Blower

- 3/4 hp
- 1 hp
- 1.5 hp
- 2 hp
- 3 hp
- 5 hp

### Motor Type

- ODP
- TEFC
- EC Motors

### Speed

- Single Speed
- 2-Speed
- 2-Speed VFD
- Variable Speed Motor
- Variable Speed VFD

## ELECTRICAL REQUIREMENTS <sup>1</sup>

- 120V/1ph/60Hz
- 208V/1ph/60Hz
- 230V/1ph/60Hz
- 208V/3ph/60Hz
- 230V/3ph/60Hz
- 460V/3ph/60Hz
- 575V/3ph/60Hz

## DISCONNECT

- Non-Fused
- Fused

## FROST CONTROL

- None
- Exhaust Defrost <sup>2</sup>
- Recirculation <sup>2</sup>
- Pre-Heat (Electric Coil)
- Pre-Heat (Hot Water Coil)

## HEATING OPTIONS

- None
- Post-Heat (Electric Coil)
- Post-Heat (Hot Water Coil)

## ADD-ONS

- Motorized & Insulated Damper for OA <sup>2</sup>
- Motorized & Insulated Damper for EA
- Non-Insulated Backdraft Damper for EA
- 24 VAC, 10 VA terminals for OA and/or EA dampers by others
- 24 VAC, 20 VA power available for accessories by others
- Spare Filters QTY: \_\_\_\_\_
- Spare Belts QTY: \_\_\_\_\_

<sup>1</sup> See pg. 2 for motor and blower restrictions.

<sup>2</sup> OA Motorized & Insulated Damper included

Project:		Architect:	
Location:		Engineer:	
Model #:		Contractor:	
Quantity:		Comments:	
Submitted By:			
Date:			