



AEROMATIC™ SERIES STANDARD COMMERCIAL  
**SE1000e**  
 Energy Recovery Ventilator

PRODUCT  
 SPECIFICATIONS  
 & TECHNICAL  
 DATA



**NOMINAL CAPACITY**  
 500-1000 CFM

**CASING – STANDARD**

- Double-wall cabinet
- 22-gauge galvanized steel interior and exterior
- Supply and exhaust hoods with bird screens
- Access doors with quarter-turn handles
- 22-gauge galvanized steel drain pan
- Drain Connections: 1" NPT
- Insulation: 1" (25 mm)

**CASING – OPTIONAL**

- Painted white baked enamel outside finish
- Pool Construction: TEFC motors, stainless steel interior, and epoxy-coated fans (NOTE: ERV not recommended for indoor pool applications)
- Removable access panels

**MOUNTING – STANDARD**

On 18-gauge galvanized steel roof curb (insulation optional)

**BLOWERS & MOTORS – STANDARD OPTIONS**

Blowers:

- Quantity: 2
- Forward-curved
- Permanently sealed and lubricated ball bearings
- Power transmission by adjustable pulleys and belts

Motors:

- Type: Inverter duty 10:1
- Maximum Power: 2 hp
- Available Voltage:
  - » 120, 208, 230 V / 1ph / 60Hz
  - » 208, 230, 460, 575 V / 3ph / 60Hz

(See table on page 2 for details)

**PLATE EXCHANGER OPTIONS**

Standard Enthalpy (sensible and latent heat transfer)

- Quantity: 1
- Pitch: 0.14" (3.5 mm)
- Dimensions: 21-7/32" x 21-7/32" x 19-3/8"  
 (539 mm x 539 mm x 492 mm)



High-Efficiency Enthalpy (sensible and latent heat transfer)

- Quantity: 1
- Pitch: 0.10" (2.5 mm)
- Dimensions: 21-7/32" x 21-7/32" x 19-3/8"  
 (539 mm x 539 mm x 492 mm)



High-Latent-Transfer Enthalpy (sensible and latent heat transfer)

- Quantity: 1
- Pitch: 0.10" (2.5 mm)
- Dimensions: 21-7/32" x 21-7/32" x 19-3/8"  
 (539 mm x 539 mm x 492 mm)



**FROST PREVENTION/CONTROL**

See page 2 for details

**ELECTRICAL & CONTROLS – STANDARD**

- 24 V double motor contactor with start-stop dry contact
- Non-fused disconnect (NEMA 4)
- 24 V transformer for controls

**ELECTRICAL & CONTROLS – OPTIONAL**

- Fused disconnect
- 24 VAC, 20 VA power available for accessories

**FILTERS – STANDARD**

Quantity: 1 supply, 1 exhaust  
 Type: MERV 8  
 Dimensions: 18" x 20" x 2" (457 mm x 508 mm x 51 mm)

**FILTERS – OPTIONAL**

MERV 13 Filters (substitute on supply air circuit only)

**WARRANTY**

Core Assembly:

- Standard & High-Efficiency Enthalpy: Limited 10-year
- High-Latent-Transfer: Limited 2-year

All Other Covered Components: Limited 2-year

**LISTED BY**



# SE1000e Features (Continued)

## FROST PREVENTION/CONTROL – OPTIONS

If no defrost mode is selected, it is the customer’s responsibility to protect the core from freezing.

Frost control activated by a temperature reference: 14°F (-10°C)

Pre-Heat in the Intake Hood:

- Powered by unit, SCR control (unavailable with 120 V)

Exhaust Defrost:

- Supply air blower shuts down and outside air damper closes. Warm exhaust air defrosts the core until it is completely defrosted.
- Includes motorized and insulated damper on fresh air intake (OA)

## OPTIONAL COMPONENTS

- Motorized and insulated damper for exhaust port (EA)
- Non-insulated backdraft damper for exhaust port (EA)
- Motorized and insulated damper on fresh air intake (OA) (included with exhaust defrost)

# SE1000e Motor & Blower Options\*

		PARAMETERS																
		HP				VOLTAGE & PHASE								MOTOR SPEED				
		3/4	1	1.5	2	1-PHASE			3-PHASE					SINGLE SPEED	2-SPEED		VARIABLE SPEED	
						120 V	208 V	230 V	208 V	230 V	460 V	575 V	MOTOR		VFD	MOTOR	VFD	
MOTOR TYPE & EFFICIENCY†	ODP, EPAct	✓	✓	✓	✓	✓	✓	✓					✓	✓	✓		✓	
	TEFC, EPAct	✓	✓			✓	✓	✓					✓		✓		✓	
	TEFC, Premium			✓	✓				✓	✓	✓	✓	✓		✓		✓	

\*See page 9 for motor sizing.

†Premium efficiency required when available.

# SE1000e Dimensions

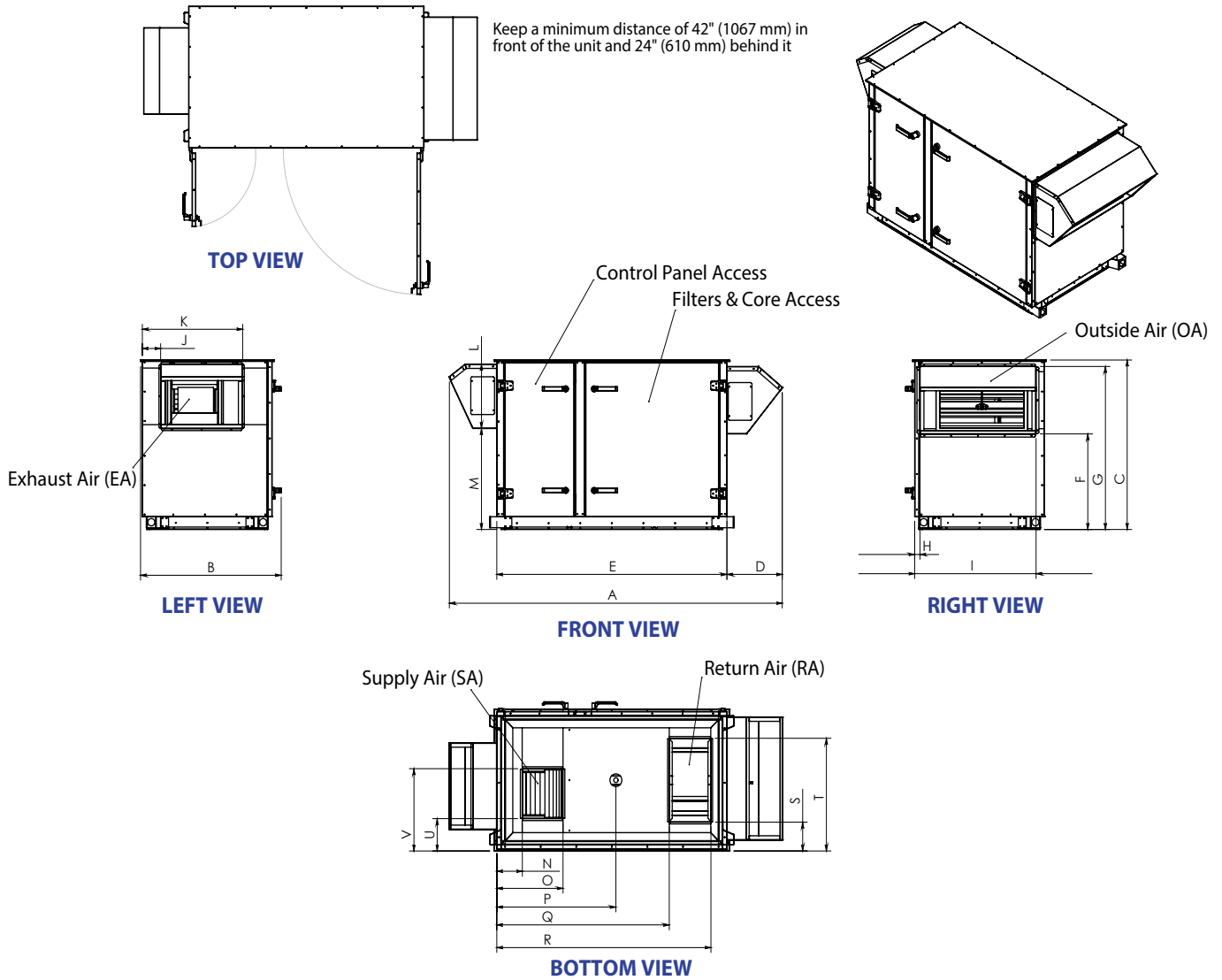

DIMENSIONS in inches (mm)											
Unit	Overall			Openings							
	A	B	C	D	E	F	G	H	I	J	K
Standard	84.25 (2140)	35.63 (905)	40.5 (1029)	14 (356)	58.25 (1480)	22.75 (578)	38.88 (987)	1.375 (35)	30.75 (781)	4.75 (121)	25.38 (645)
Pre-Heat Option	109.75 (2788)	35.63 (905)	40.5 (1029)	39.5 (1003)	58.25 (1480)	22.75 (578)	38.88 (987)	1.375 (35)	30.75 (781)	4.75 (121)	25.38 (645)
Unit	Openings										
	L	M	N	O	P	Q	R	S	T	U	V
Standard	15.38 (391)	24.13 (613)	6.5 (165)	16.88 (429)	30.25 (768)	43.75 (1111)	54.13 (1375)	6.5 (165)	26.38 (670)	7.38 (187)	19 (483)
Pre-Heat Option	15.38 (391)	24.13 (613)	6.5 (165)	16.88 (429)	30.25 (768)	43.75 (1111)	54.13 (1375)	6.5 (165)	26.38 (670)	7.38 (187)	19 (483)

# SE1000e Configurations & Weights

AVAILABLE CONFIGURATIONS*
1-2-5-6**
1-3-5-6**
1-2-4-6
1-3-4-6

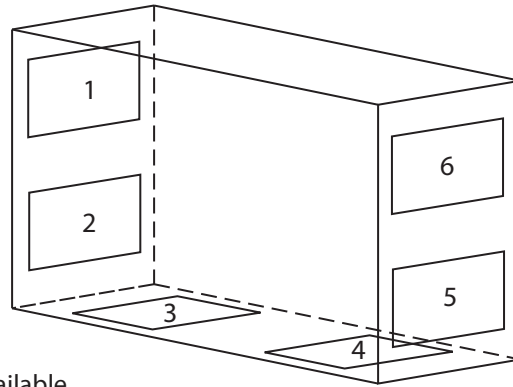

DUCT CONNECTION KEY	
1	Exhaust Air (EA)
2, 3	Supply Air (SA)
4, 5	Return Air (RA)
6	Outside Air (OA)

\*Mirror Image Cabinet Also Available

\*\*Not available with pre-heat option

SE1000e WEIGHTS & DIMENSIONS †	
Minimum Unit Weight	582 lbs (264 kg)
Maximum Unit Weight	694 lbs (315 kg)
Minimum Shipping Weight	642 lbs (291 kg)
Maximum Shipping Weight	754 lbs (342 kg)

† Actual weight may vary by ±10%.  
Roof curb shipped separately.

# SE1000e Roof Curb Dimensions

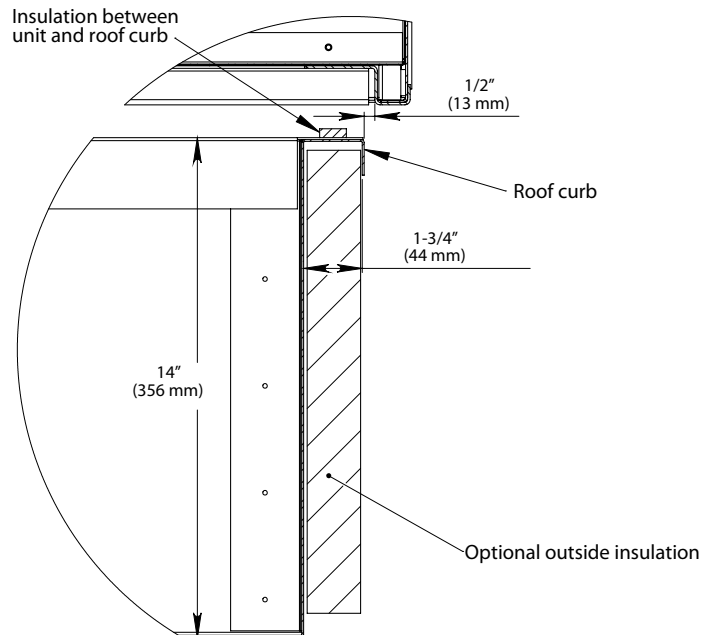
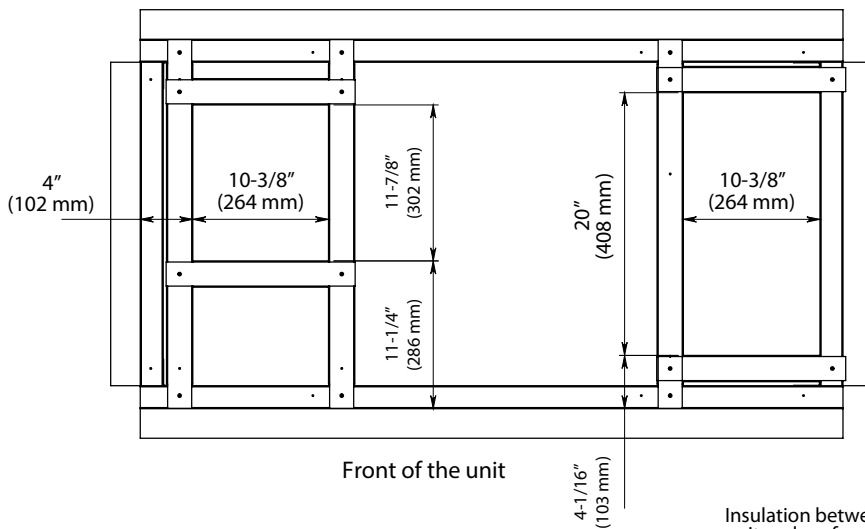
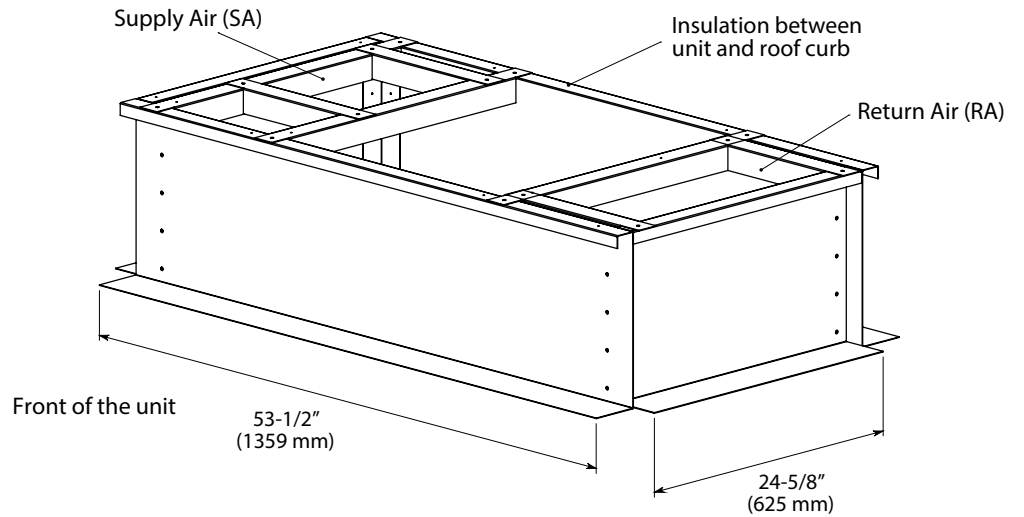

SE1000e ROOF CURB WEIGHTS & DIMENSIONS	
Roof Curb Weight	60 lbs (27 kg)
Shipping Weight	85 lbs (39 kg)
Shipping Dimensions (W x H x D)	60" x 20" x 25" (1524 mm x 508 mm x 635 mm)

# Standard Enthalpy Core Performance

AHRI STANDARD CONDITIONS	CONDITIONS	
Outside Air Temperature	Winter	Summer
Dry Bulb	35°F (1.7°C)	95°F (35°C)
Wet Bulb	33°F (0.6°C)	78°F (25.6°C)
Exhaust Air Temperature	Winter	Summer
Dry Bulb	70°F (21.1°C)	75°F (23.9°C)
Wet Bulb	58°F (14.4°C)	63°F (17.2°C)

Note: Efficiencies are based on AHRI standard winter conditions.

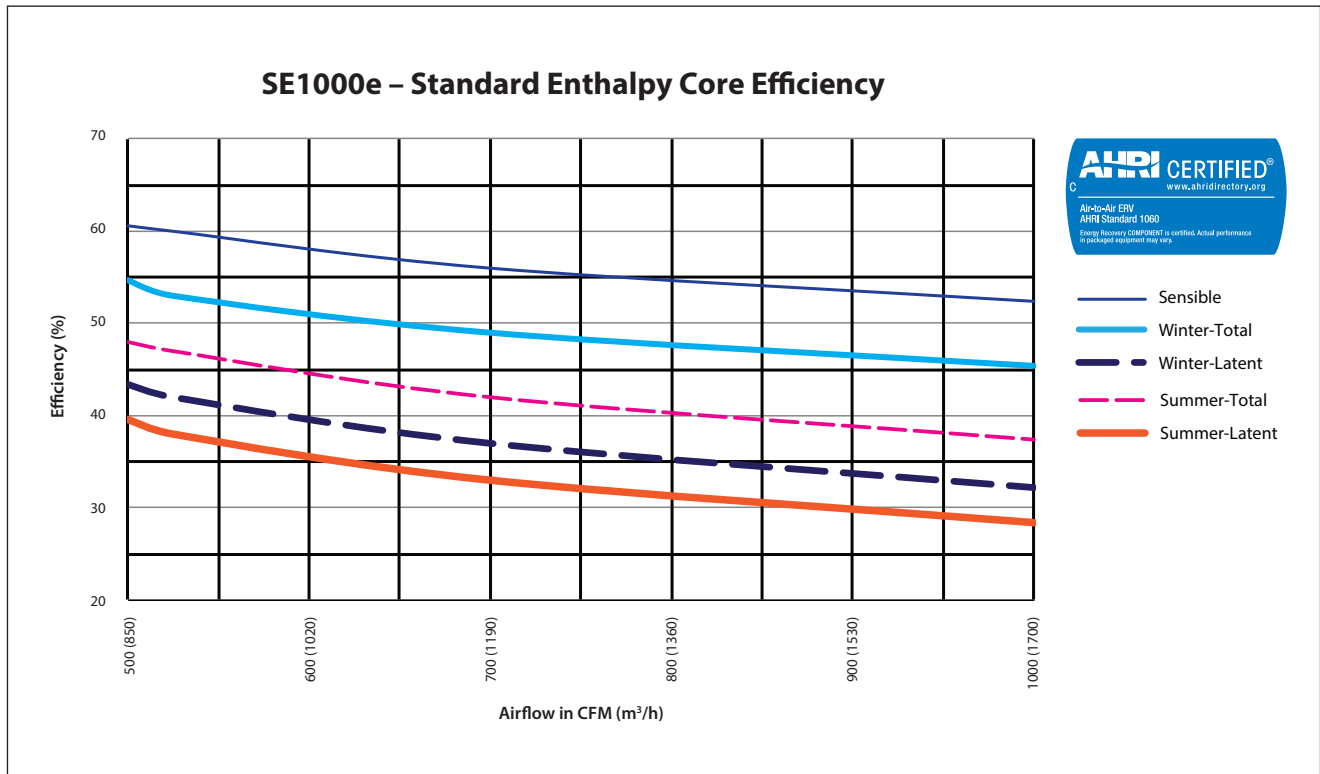

# High-Efficiency Enthalpy Core Performance

AHRI STANDARD CONDITIONS	CONDITIONS	
Outside Air Temperature	Winter	Summer
Dry Bulb	35°F (1.7°C)	95°F (35°C)
Wet Bulb	33°F (0.6°C)	78°F (25.6°C)
Exhaust Air Temperature	Winter	Summer
Dry Bulb	70°F (21.1°C)	75°F (23.9°C)
Wet Bulb	58°F (14.4°C)	63°F (17.2°C)

Note: Efficiencies are based on AHRI standard winter conditions.

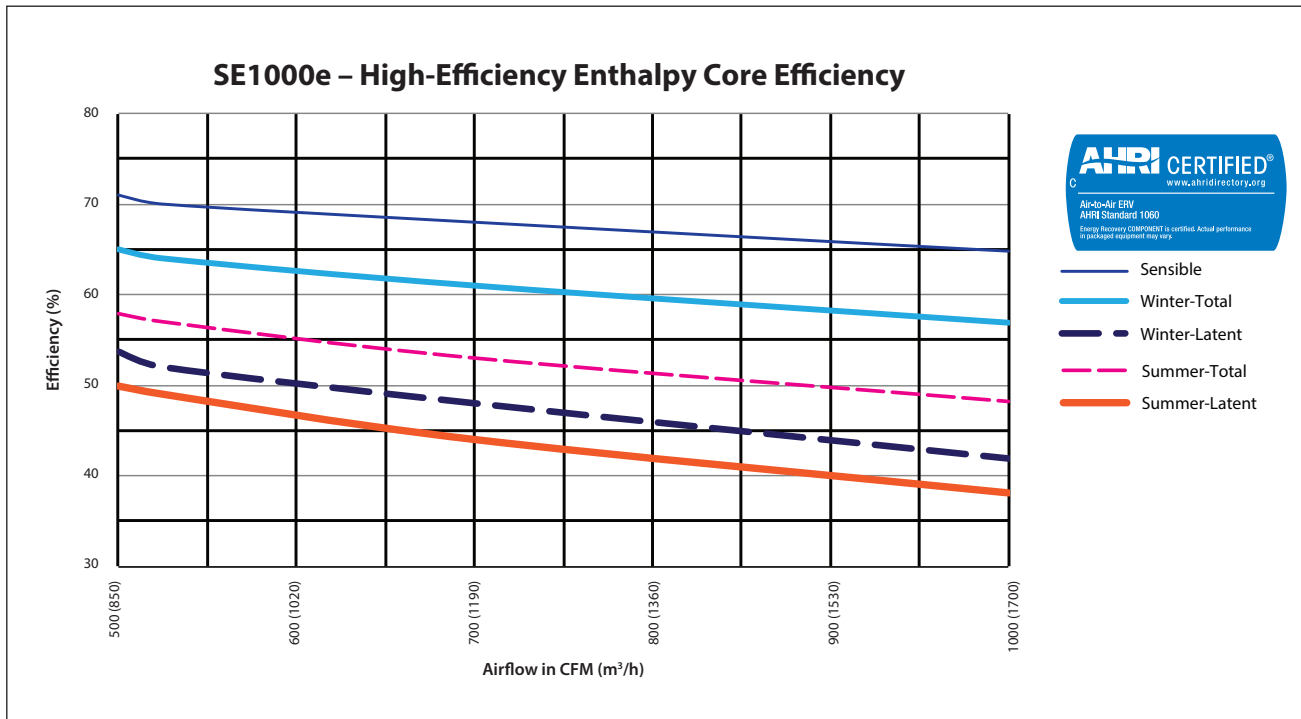

# High-Latent-Transfer Enthalpy Core Performance

AHRI STANDARD CONDITIONS	CONDITIONS	
Outside Air Temperature	Winter	Summer
Dry Bulb	35°F (1.7°C)	95°F (35°C)
Wet Bulb	33°F (0.6°C)	78°F (25.6°C)
Exhaust Air Temperature	Winter	Summer
Dry Bulb	70°F (21.1°C)	75°F (23.9°C)
Wet Bulb	58°F (14.4°C)	63°F (17.2°C)

Note: Efficiencies are based on AHRI standard winter conditions.

## SE1000e – High-Latent-Transfer Enthalpy Core Efficiency

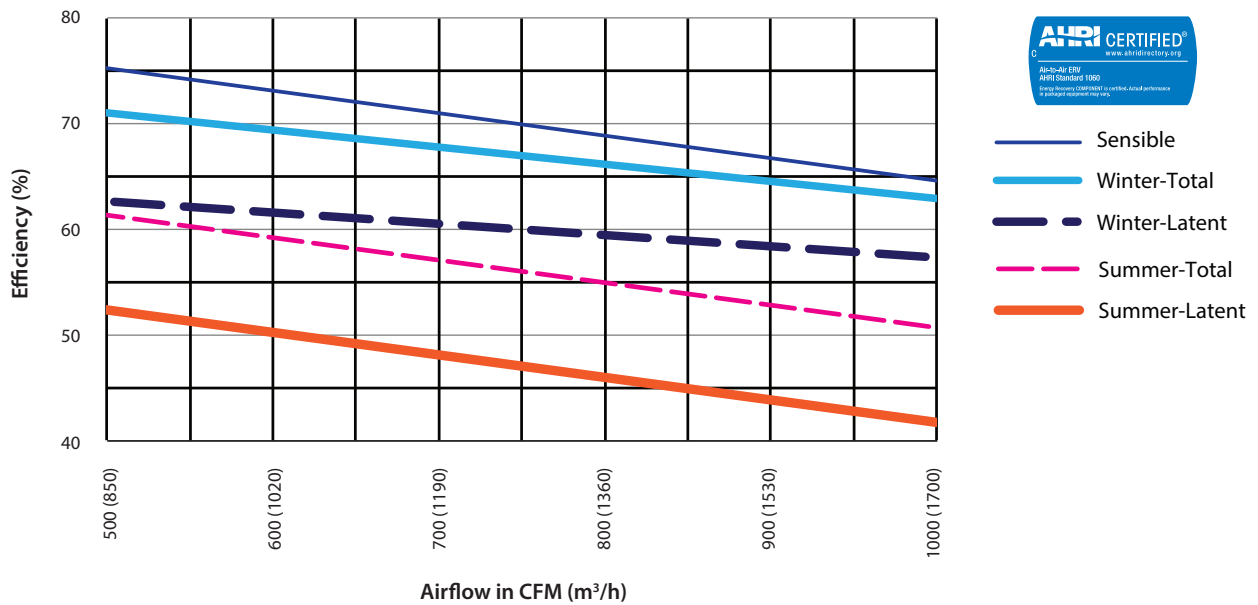



## Motor Selection – Standard Enthalpy Core

SUPPLY/EXHAUST																				
MOTOR	CFM (m <sup>3</sup> /h)	EXTERNAL STATIC PRESSURE (inH <sub>2</sub> O) - SUPPLY/EXHAUST																		MOTOR
		0.25 (60 Pa)			0.50 (125 Pa)			0.75 (185 Pa)			1.00 (250 Pa)			1.25 (310 Pa)			1.50 (375 Pa)			
		RPM	BHP	HP	RPM	BHP	HP	RPM	BHP	HP	RPM	BHP	HP	RPM	BHP	HP	RPM	BHP	HP	
3/4 hp	500 (850)	917	0.14	0.17	1057	0.19	0.23	1179	0.25	0.30	1287	0.32	0.38	1385	0.38	0.46	1476	0.45	0.54	3/4 hp
	600 (1020)	983	0.18	0.22	1117	0.24	0.29	1235	0.31	0.37	1341	0.38	0.46	1437	0.45	0.54	1527	0.53	0.64	
	700 (1190)	1042	0.23	0.28	1173	0.30	0.36	1288	0.37	0.44	1392	0.45	0.54	1487	0.53	0.64	1576	0.62	0.74	
	800 (1360)	1099	0.28	0.34	1231	0.37	0.44	1343	0.45	0.54	1445	0.54	0.65	1538	0.62	0.74	1626	0.71	0.85	1 hp
	900 (1530)	1151	0.34	0.41	1281	0.44	0.53	1394	0.53	0.64	1495	0.62	0.74	1587	0.72	0.86	1673	0.82	0.98	
	1000 (1700)	1199	0.41	0.49	1326	0.51	0.61	1439	0.61	0.73	1541	0.72	0.86	1633	0.82	0.98	1718	0.93	1.12	

## Motor Selection – High-Efficiency Enthalpy Core

SUPPLY/EXHAUST																				
MOTOR	CFM (m <sup>3</sup> /h)	EXTERNAL STATIC PRESSURE (inH <sub>2</sub> O) - SUPPLY/EXHAUST																		MOTOR
		0.25 (60 Pa)			0.50 (125 Pa)			0.75 (185 Pa)			1.00 (250 Pa)			1.25 (310 Pa)			1.50 (375 Pa)			
		RPM	BHP	HP	RPM	BHP	HP	RPM	BHP	HP	RPM	BHP	HP	RPM	BHP	HP	RPM	BHP	HP	
3/4 hp	500 (850)	1031	0.18	0.22	1155	0.24	0.29	1265	0.30	0.36	1366	0.37	0.44	1458	0.44	0.53	1545	0.51	0.61	3/4 hp
	600 (1020)	1102	0.24	0.29	1221	0.30	0.36	1328	0.37	0.44	1426	0.45	0.54	1516	0.52	0.62	1601	0.60	0.72	
	700 (1190)	1173	0.30	0.36	1288	0.37	0.44	1392	0.45	0.54	1487	0.53	0.64	1576	0.62	0.74	1659	0.70	0.84	
	800 (1360)	1240	0.37	0.44	1352	0.46	0.55	1453	0.54	0.65	1546	0.63	0.76	1633	0.72	0.86	1714	0.81	0.97	1 hp
	900 (1530)	1309	0.46	0.55	1419	0.55	0.66	1517	0.65	0.78	1608	0.74	0.89	1693	0.84	1.01	1773	0.94	1.13	
	1000 (1700)	1372	0.55	0.66	1482	0.66	0.79	1578	0.76	0.91	1667	0.86	1.03	1751	0.97	1.16	1829	1.08	1.30	

## Motor Selection – High-Latent-Transfer Enthalpy Core

SUPPLY/EXHAUST																				
MOTOR	CFM (m <sup>3</sup> /h)	EXTERNAL STATIC PRESSURE (inH <sub>2</sub> O) - SUPPLY/EXHAUST																		MOTOR
		0.25 (60 Pa)			0.50 (125 Pa)			0.75 (185 Pa)			1.00 (250 Pa)			1.25 (310 Pa)			1.50 (375 Pa)			
		RPM	BHP	HP	RPM	BHP	HP	RPM	BHP	HP	RPM	BHP	HP	RPM	BHP	HP	RPM	BHP	HP	
3/4 hp	500 (850)	1068	0.20	0.24	1188	0.26	0.31	1295	0.32	0.38	1393	0.39	0.47	1483	0.46	0.55	1568	0.53	0.64	3/4 hp
	600 (1020)	1152	0.26	0.31	1266	0.33	0.40	1369	0.40	0.48	1463	0.48	0.58	1551	0.55	0.66	1634	0.63	0.76	
	700 (1190)	1226	0.33	0.40	1335	0.41	0.49	1435	0.49	0.59	1527	0.57	0.68	1613	0.65	0.78	1694	0.74	0.89	
	800 (1360)	1295	0.41	0.49	1401	0.50	0.60	1498	0.58	0.70	1588	0.67	0.80	1672	0.76	0.91	1752	0.86	1.03	1 hp
	900 (1530)	1364	0.50	0.60	1467	0.60	0.72	1561	0.69	0.83	1649	0.79	0.95	1732	0.89	1.07	1810	0.99	1.19	
	1000 (1700)	1426	0.60	0.72	1530	0.71	0.85	1622	0.81	0.97	1708	0.92	1.10	1789	1.02	1.22	1866	1.13	1.36	

NOTES: hp = bhp x 1.2

Internal static pressure will vary based on selected options.

## Additional Air Pressure Drop with MERV 13 Filters

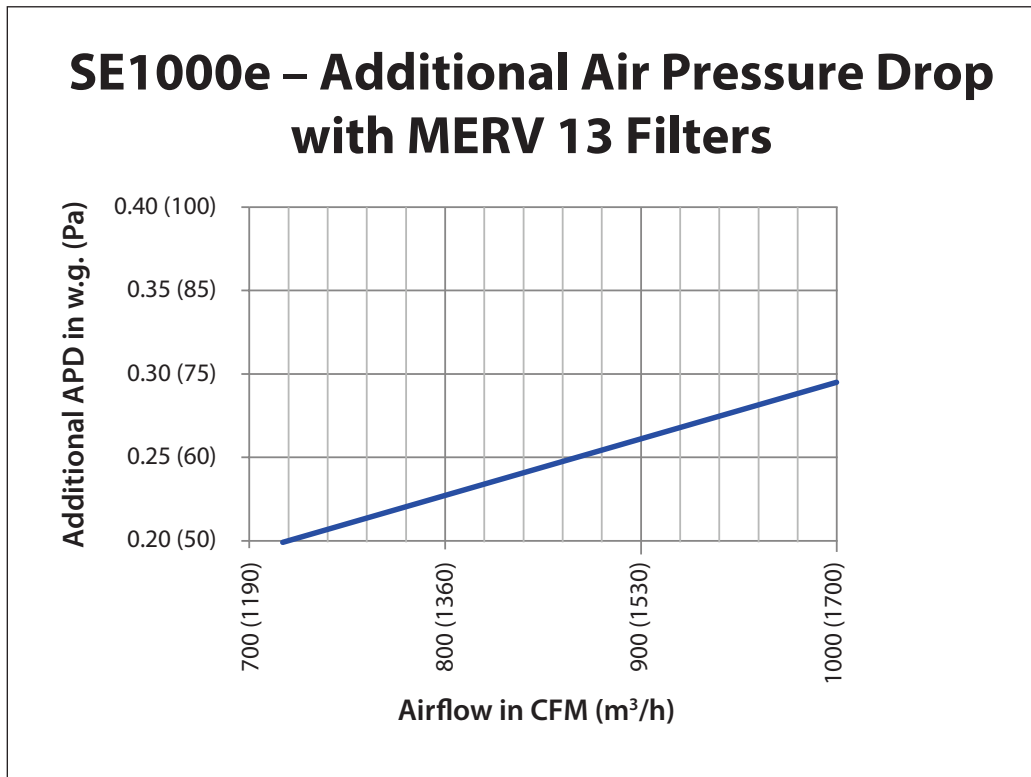

# Selection Information

▲ = Standard Feature

☐ = Optional Feature (check the box to select this option)

Send your completed selection to your Aldes Canada Representative.

## MODEL

Series: Standard Commercial (SE)

Nominal Capacity: 500-1000 CFM

Application: Exterior (e)

## CASING & CORE

### Cabinet Finish

- Galvanized
- Painted
- Pool Construction

### Duct Configuration (see pg. 4)

- 1-2-5-6 <sup>1</sup>
- 1-3-5-6 <sup>1</sup>
- 1-2-4-6
- 1-3-4-6

### Mirror Image Cabinet

- Optional

### Access Doors

- Fixed/Hinged
- Removable Panels

### Roof Curb

- Insulated
- Non-Insulated

### Plate Exchanger

- Standard Enthalpy
- High-Efficiency Enthalpy
- High-Latent-Transfer Enthalpy

## BLOWERS & MOTORS <sup>2</sup>

### Supply Blower

- 3/4 hp
- 1 hp
- 1.5 hp
- 2 hp

### Exhaust Blower

- 3/4 hp
- 1 hp
- 1.5 hp
- 2 hp

### Motor Type

- ODP
- TEFC

### Speed

- Single Speed
- 2-Speed
- 2-Speed VFD
- Variable Speed Motor
- Variable Speed VFD

## ELECTRICAL REQUIREMENTS <sup>2</sup>

- 120V/1ph/60Hz
- 208V/1ph/60Hz
- 230V/1ph/60Hz
- 208V/3ph/60Hz
- 230V/3ph/60Hz
- 460V/3ph/60Hz
- 575V/3ph/60Hz

## DISCONNECT

- Non-Fused
- Fused

## FROST CONTROL

- None
- Exhaust Defrost <sup>3</sup>
- Pre-Heat (Electric Coil)

## FILTERS (SUPPLY)

- MERV 8
- MERV 13

## ADD-ONS

- Motorized & Insulated Damper for OA <sup>3</sup>
- Motorized & Insulated Damper for EA
- Non-Insulated Backdraft Damper for EA
- 24 VAC, 10 VA terminals for OA and/or EA dampers by others
- 24 VAC, 20 VA power available for accessories by others
- Spare Filters QTY: \_\_\_\_\_
- Spare Belts QTY: \_\_\_\_\_

<sup>1</sup> Configuration not available with pre-heat option

<sup>2</sup> See pg. 2 for motor and blower restrictions

<sup>3</sup> OA Motorized & Insulated Damper included

Project:		Architect:	
Location:		Engineer:	
Model #:		Contractor:	
Quantity:		Comments:	
Submitted By:			
Date:			

2016 ALDES Canada. Toute reproduction ou distribution de ce document, entier ou en partie sous quelque forme que ce soit sans le consentement écrit d'ALDES Canada, est strictement interdit. L'information contenu dans ce document est sujet à changement sans aucun préavis.