



AEROMATIC™ SERIES ADVANCED COMMERCIAL  
**CW3000**  
Energy Recovery Ventilator

PRODUCT  
SPECIFICATIONS  
& TECHNICAL  
DATA

## Standard Features



*Interior Unit CW3000i*



*Exterior Unit CW3000e*

### NOMINAL CAPACITY

2000-3400 CFM

### CASING

Double-wall cabinet  
White exterior paint, 22-gauge galvanized steel  
18-gauge galvanized steel interior walls  
Access doors with quarter-turn handles  
18-gauge stainless steel drain pan  
Drain Connections: 1" NPT  
Insulation: 2" (51 mm)

### MOUNTING

On roof curb or on platform

### ENTHALPY WHEEL

Material: Polymer with desiccant wheel technology  
Type: Channel matrix with removable segments  
Wheel diameter: 41" (1041 mm)  
L-10 class ball bearings  
Drive Belt: Urethane



### BLOWERS

Quantity: 2

- Forward-curved
- Permanently sealed and lubricated ball bearings
- Power transmission by adjustable pulleys and belts

### MOTORS

Type: Inverter duty 10:1, ODP or TEFC, EPAct or Premium  
Maximum Power: 5 hp  
Drive Assembly/Blower: On vibration-isolating springs

### FILTERS

Type: MERV 8  
Quantity: 2 per circuit  
Dimensions: 20" x 24" x 4" (508 mm x 610 mm x 102 mm)

### ELECTRICAL & CONTROLS

- Start/stop dry contact and general alarm dry contact
- Occupancy control dry contact
- Fan interlock dry contact
- Start/stop dry contact for the wheel (free cooling)
- 24VAC, 20VA power available for accessories
- Access panel with non-fused disconnect (NEMA 4)
- Single-point power connection
- 120, 208, 230 V / 1ph / 60Hz
- 208, 230, 460, 575 V / 3ph / 60Hz

### WARRANTY

- Wheel: Limited 2-year warranty
- All Other Covered Components: Limited 2-year warranty

### LISTED BY



# Optional Features

## FROST PREVENTION/CONTROL OPTIONS

Frost control activated by a temperature reference  
Set point: 5°F (-15°C)

Internal Pre-Heat by Electric Coil:

- Powered by unit
- Factory calibrated
- SCR control

Internal Pre-Heat by Hot Water Coil:

- 0-10 V signal on the control panel
- Front or back piping connections

Wheel Speed Variation (VFD)

Defrost Cycles:

- Exhaust Only or Recirculation
- Comes with motorized and insulated damper on OA only
- See table below for temperature references

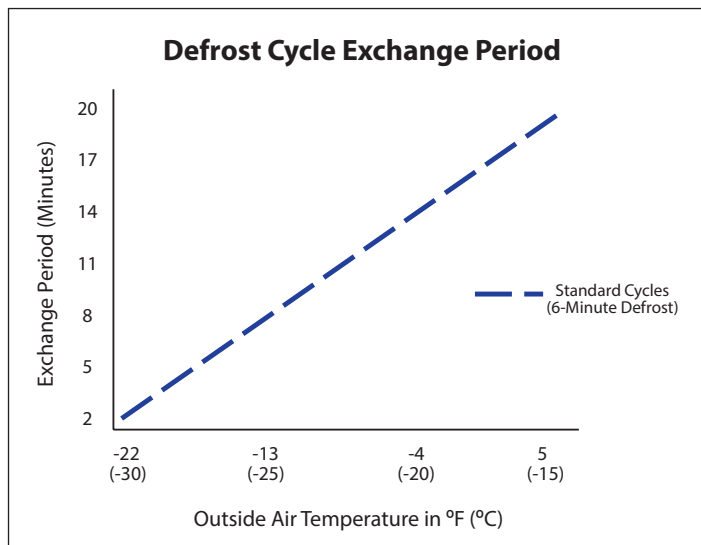

## AVAILABLE OPTIONS

### Cabinet Options:

- Supply and Exhaust Hoods with bird screens
- Roof Curb: 14" (356 mm) high, 18-gauge galvanized steel, insulation optional
- Front or back piping connections (drain pan and water coil and/or cooling connections)
- Pool Construction: TEFC motors, stainless steel interior, and epoxy-coated fans (NOTE: ERV not recommended for indoor pool applications)

## AVAILABLE OPTIONS

### Components Options:

- Final MERV 13 filters added to the fresh air circuit
- Motorized and insulated dampers (on OA and/or EA openings)
- Non-insulated backdraft damper (on EA opening only)
- Post-Heat by Electric Coil: Powered by unit
- Post-Heat by Hot Water Coil: 0-10VDC signal to maintain supply air temperature, or 0-10VDC signal by others
- Cold Water Cooling Coil: Control by others, comes with 18-gauge stainless steel drain pan
- DX Cooling Coil: All controls and condensation unit by others, comes with 18-gauge stainless steel drain pan
- Mechanical Purge

### Blower Motor Options:

- TEFC, Premium (only available with ≥1.5 hp/ 3ph)
- 2-Speed motors (only available with ODP, EPAAct motors)
- Programmable 2-Speed (VFD)
- Variable Frequency Drive (VFD), 0-10VDC control signal by others
- Backward-inclined blowers

### Control Options:

- Economizer Cycle: Free cooling management by temperature sensor on OA
- Dirty Filters Contact: Will close a dry contact when dirty filters are detected
- Low Airflow Switch: Will open a dry contact when no airflow is detected on supply blower
- Low Temperature Limit: Unit will stop if fresh air supply is under set point (adjustable) for more than 5 minutes
- Phase Loss Detection: Unit will stop when a phase loss occurs, automatic restart (3-phase power only)
- Wheel Rotation Detection: A dry contact will close if no rotation is detected
- Damper End Switch: Unit start up conditional to dampers opening
- Recirculation Dry Contact: For unoccupied mode, must select recirculation defrost option
- Terminals for OA and/or EA damper power and control (24VAC, 10VA): Included when OA/EA damper selected
- Programmable Timer
- CO<sub>2</sub> or Relative Humidity (RH) Sensor: Sequence of operations must be verified by factory
- BacNet Compatible Controller
  - Available Upgrades:
    - » IP Communication Network Module
    - » MS/TP Communication Network Module
    - » Remote Keypad
    - » Remote Keypad with Touchscreen

# Components

Exhaust Damper Option for Interior Unit

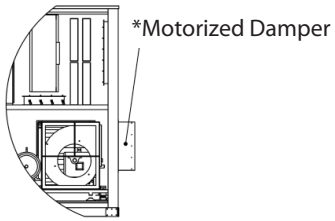

\*Motorized Damper

Exhaust Hood Option for Exterior Unit

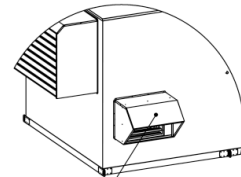

\*Exhaust Hood

\*Post-Cooling Coil (water), rear connection

\*Post-Heat Coil (electric or hot water), rear connection

\*Motorized Damper

\*MERV 8 Filters

\*MERV 13 Filters

\*Pre-Heat Coil (electric or hot water)

Enthalpy Wheel

Supply Blower

Motor

\*Supply Hood with bird screen

\*Recirculation Damper

Control Panel

Exhaust Blower

MERV 8 Filters

Motor

\* = OPTIONAL FEATURE

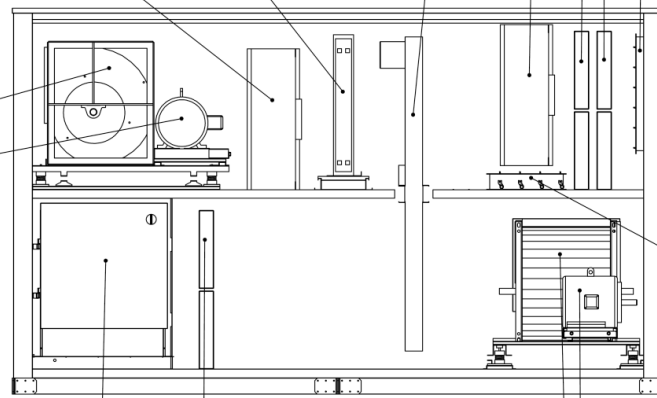

# Configurations

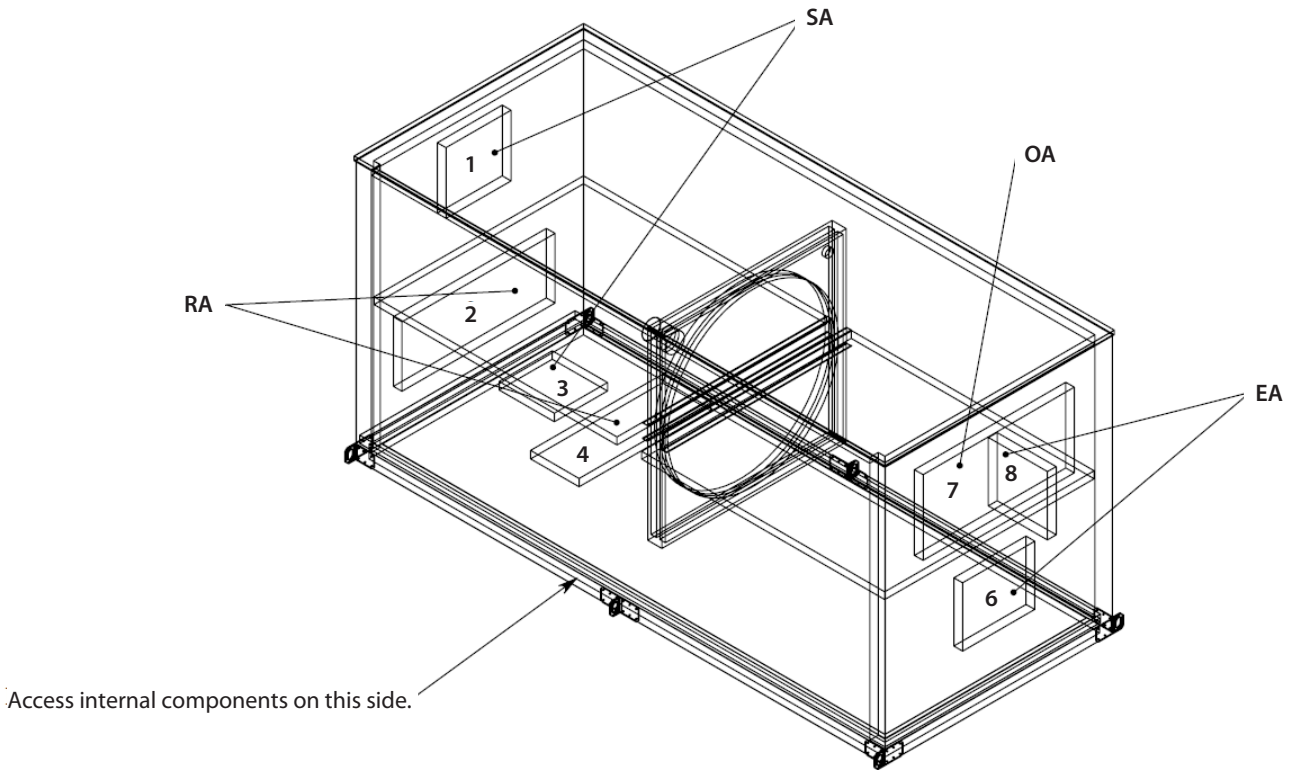

AVAILABLE CONFIGURATIONS
3-4-7-8
3-4-6-7 *
1-2-7-8
1-2-6-7 *
1-4-7-8
1-4-6-7 *
2-3-7-8
2-3-6-7 *

LEGEND	
RA	Return Air
SA	Supply Air
OA	Outside Air
EA	Exhaust Air

Mirror Image Cabinet Also Available

\* = Configuration not available with hoods option

# Dimensions & Weights

CABINET*																		
Unit	Height		Width				Length											V
	A	B	Overall		Overall - Standard				Overall - 1 Coil Option				Overall - 2 Coils Option					
			C	D	D	E		D	E		D	E						
Overall	Base - Standard	Standard	Hoods Option	Base - Standard	Standard	Motorized Exhaust Damper Option	Hoods Option	Base - Standard	Standard	Motorized Exhaust Damper option	Hoods Option	Base - Standard	Standard	Motorized Exhaust Damper Option	Hoods Option	Front Clearance Required		
CW3000	71.1 (1806)	52.6 (1336)	58.4 (1483)	78.3 (1989)	101.8 (2586)	103.6 (2631)	111.8 (2840)	122.3 (3106)	121.3 (3081)	127.3 (3233)	131.8 (3348)	142.3 (3614)	141.3 (3589)	147.3 (3741)	151.8 (3856)	162.3 (4122)	47 (1194)	

OPENINGS*															
Unit	F	G	H	I	J	K	L	M	P	Q	R	S	T	U	
CW3000	18 (457)	16 (406)	28 (711)	18 (457)	18 (457)	16 (406)	28 (711)	18 (457)	18 (457)	16 (406)	28 (711)	18 (457)	18 (457)	16 (406)	

\* All dimensions in inches (mm)

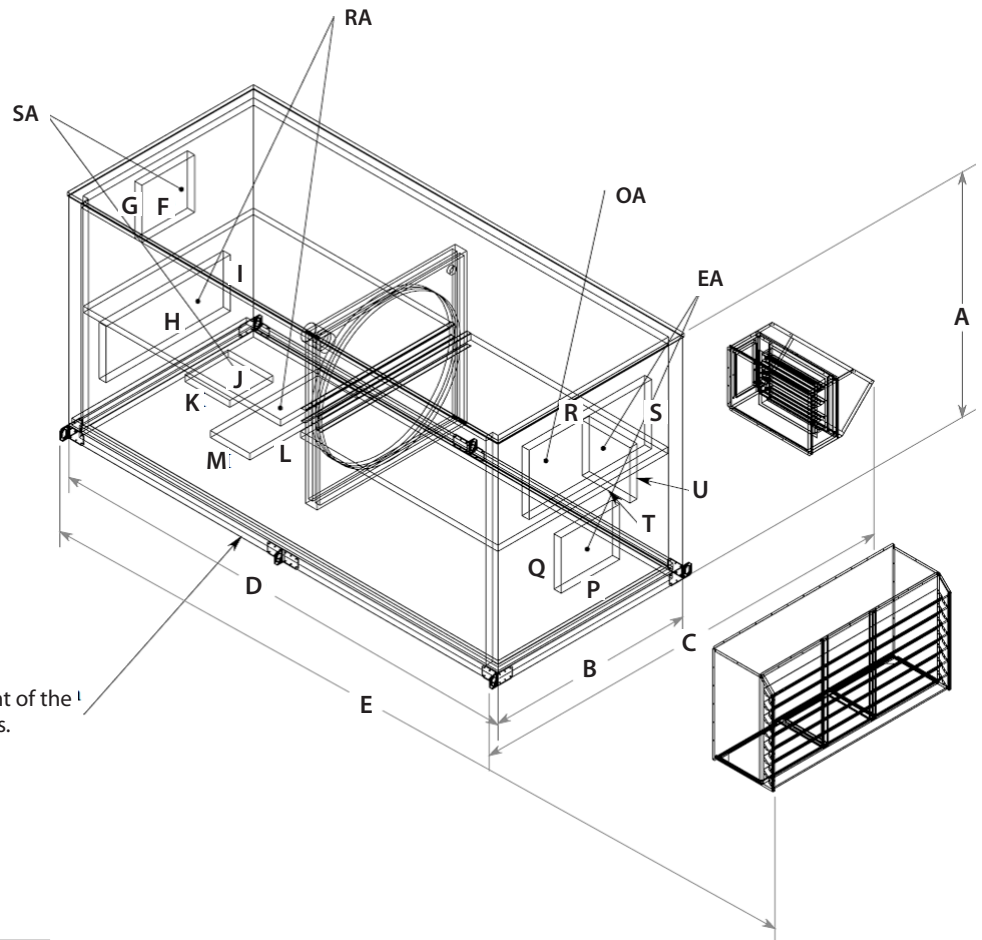

Dimension "V": Clearance required in front of the unit for access to the internal components.

WEIGHT - CW3000†	
Minimum	2301 lbs (1044 kg)
Maximum	3261 lbs (1479 kg)

† Actual weight may vary by ±10%. Shipping weight calculated after final selection. Roof curbs shipped separately.

# Roof Curb Dimensions

NOTE: Drawings not to scale

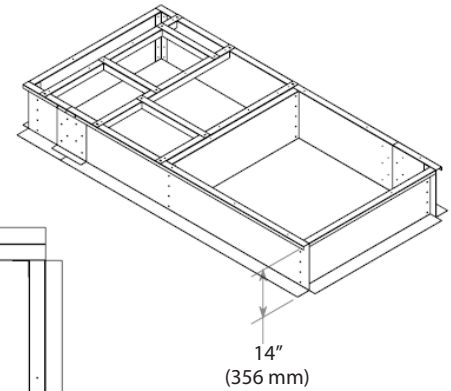
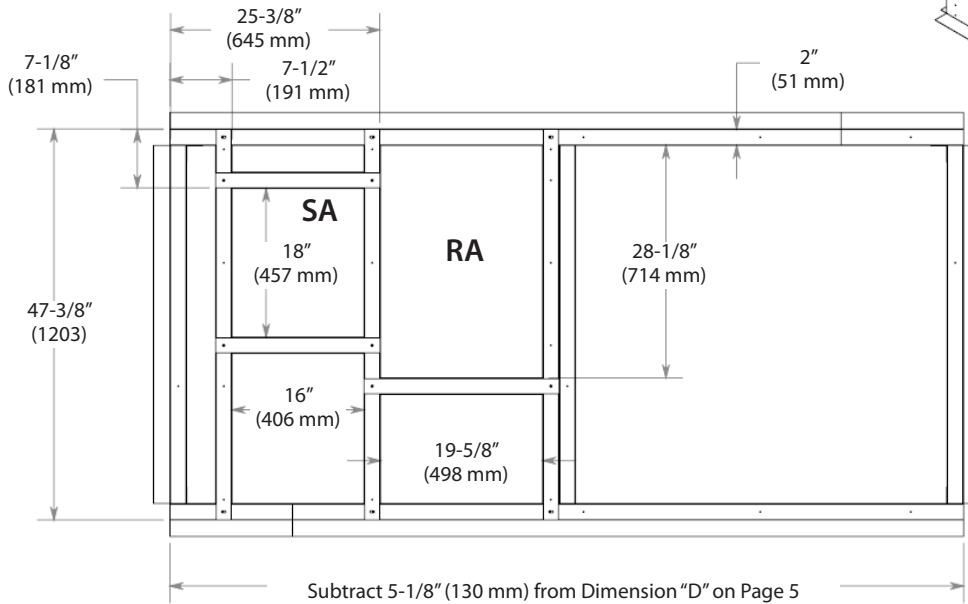

# Roof Curb Assembly

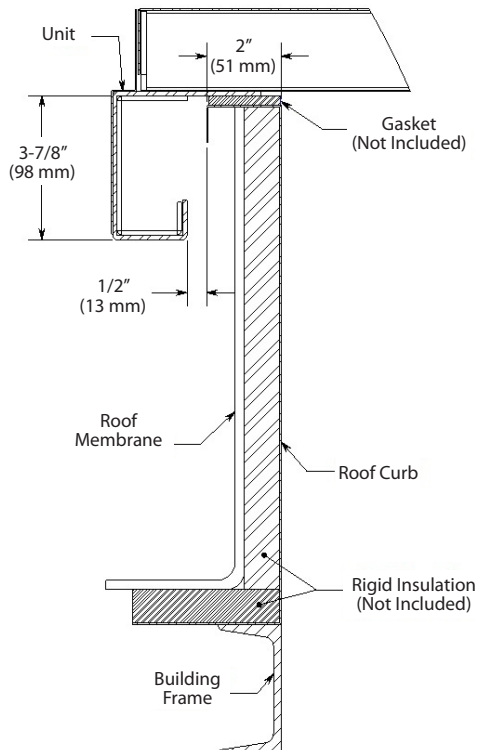

ROOF CURB WEIGHTS & DIMENSIONS	
Roof Curb Weight	120 lbs (54 kg)
Shipping Weight	165 lbs (75 kg)
Shipping Dimensions (W x H x D)	96" x 24" x 25" (2438 mm x 610 mm x 635 mm)

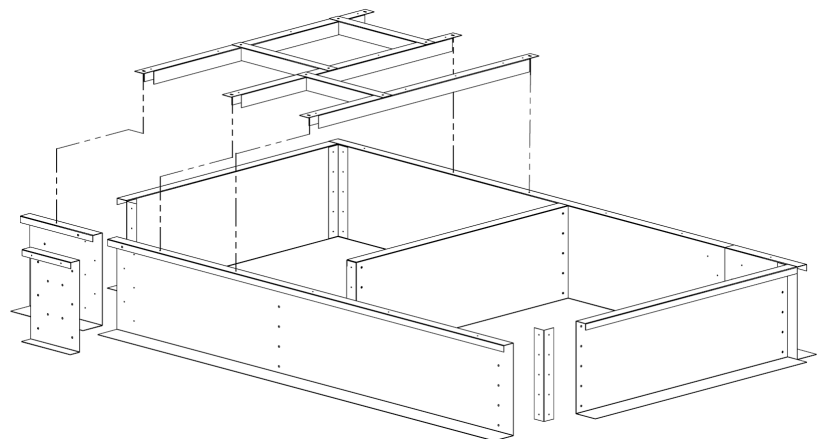

# Enthalpy Wheel Performance

AHRI STANDARD CONDITIONS	CONDITIONS	
Outside Temperature	Winter	Summer
Dry Bulb	35°F (1.7°C)	95°F (35°C)
Wet Bulb	33°F (0.6°C)	78°F (25.6°C)
Exhaust Air Temperature	Winter	Summer
Dry Bulb	70°F (21.1°C)	75°F (23.9°C)
Wet Bulb	58°F (14.4°C)	63°F (17.2°C)

Note: Efficiencies are based on AHRI standard winter conditions.

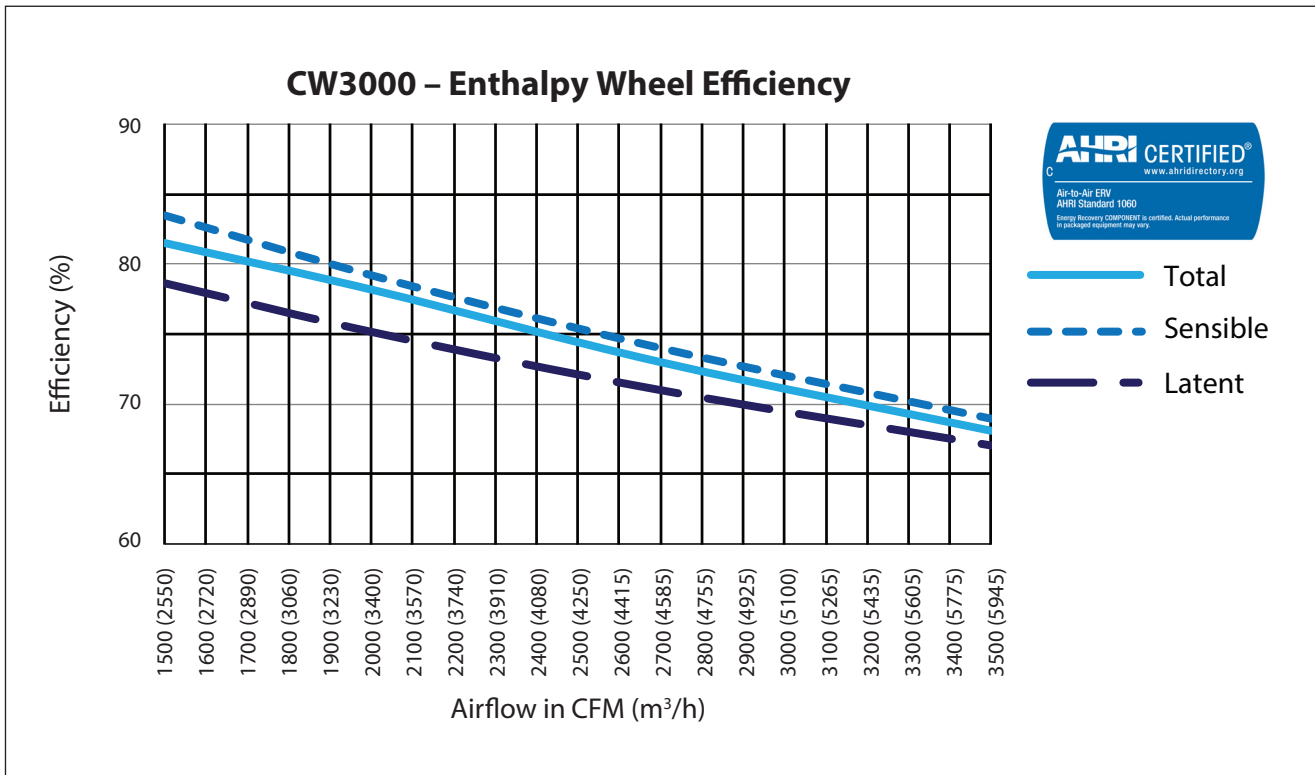

## Motor Selection – Enthalpy Wheel

SUPPLY/EXHAUST																				
MOTOR	AIRFLOW	EXTERNAL STATIC PRESSURE (IN H <sub>2</sub> O) - SUPPLY/EXHAUST																		MOTOR
		0.25 (60 Pa)			0.50 (125 Pa)			0.75 (185 Pa)			1.00 (250 Pa)			1.25 (310 Pa)			1.50 (375 Pa)			
		CFM (m <sup>3</sup> /h)	RPM	BHP	HP	RPM	BHP	HP	RPM	BHP	HP	RPM	BHP	HP	RPM	BHP	HP	RPM	BHP	
1 hp	2000 (3400)	1023	0.79	0.95	1105	0.90	1.08	1183	1.01	1.21	1263	1.12	1.34	1338	1.25	1.50	1411	1.37	1.64	2 hp
1.5 hp	2100 (3570)	1039	0.87	1.04	1119	0.98	1.17	1195	1.09	1.31	1273	1.21	1.45	1346	1.34	1.61	1416	1.46	1.75	2 hp
	2200 (3740)	1054	0.95	1.13	1133	1.06	1.28	1208	1.18	1.42	1283	1.30	1.56	1354	1.43	1.72	1422	1.56	1.87	
	2300 (3910)	1070	1.03	1.24	1147	1.15	1.38	1221	1.27	1.53	1293	1.40	1.68	1362	1.53	1.84	1429	1.66	1.99	
	2400 (4080)	1085	1.12	1.35	1161	1.25	1.50	1233	1.37	1.65	1304	1.50	1.80	1371	1.64	1.97	1435	1.77	2.12	
2 hp	2500 (4250)	1100	1.22	1.46	1174	1.35	1.62	1246	1.48	1.77	1314	1.61	1.93	1380	1.75	2.10	1443	1.88	2.26	3 hp
	2600 (4415)	1116	1.32	1.58	1188	1.45	1.74	1258	1.59	1.90	1325	1.73	2.07	1390	1.87	2.24	1451	2.00	2.41	
	2700 (4585)	1130	1.43	1.71	1202	1.57	1.88	1271	1.70	2.04	1336	1.85	2.21	1399	1.99	2.39	1459	2.13	2.56	
	2800 (4755)	1145	1.54	1.85	1215	1.68	2.02	1283	1.82	2.19	1348	1.97	2.37	1409	2.12	2.54	1468	2.26	2.72	
3 hp	2900 (4925)	1160	1.66	1.99	1229	1.80	2.17	1296	1.95	2.34	1359	2.10	2.52	1420	2.25	2.70	1478	2.40	2.88	5 hp
	3000 (5100)	1174	1.78	2.14	1243	1.93	2.32	1308	2.08	2.50	1370	2.24	2.69	1431	2.39	2.87	1488	2.55	3.06	
	3100 (5265)	1189	1.91	2.29	1256	2.07	2.48	1321	2.22	2.67	1382	2.38	2.86	1442	2.54	3.04	1498	2.70	3.24	
	3200 (5434)	1203	2.04	2.45	1269	2.20	2.65	1333	2.36	2.84	1394	2.53	3.30	1453	2.69	3.23	1509	2.85	3.42	
	3300 (5605)	1217	2.18	2.62	1283	2.35	2.82	1346	2.51	3.02	1406	2.68	3.22	1465	2.85	3.42	1521	3.01	3.62	
	3400 (5775)	1231	2.33	2.80	1296	2.50	3.00	1358	2.67	3.20	1419	2.84	3.41	1477	3.01	3.61	1533	3.18	3.82	

NOTE:  
hp = bhp x 1.2

## Additional Air Pressure Drop with MERV 13 Filters

Airflow CFM (m <sup>3</sup> /h)	APD in. H <sub>2</sub> O (Pa)
2000 (3400)	0.12 (30)
2100 (3570)	0.13 (33)
2200 (3740)	0.14 (35)
2300 (3910)	0.15 (38)
2400 (4080)	0.16 (41)
2500 (4250)	0.17(43)
2600 (4415)	0.18 (46)
2700 (4585)	0.20 (49)

Airflow CFM (m <sup>3</sup> /h)	APD in. H <sub>2</sub> O (Pa)
2800 (4755)	0.21 (51)
2900 (4925)	0.22 (54)
3000 (5100)	0.23 (57)
3100 (5265)	0.24 (59)
3200 (5435)	0.25 (62)
3300 (5605)	0.26 (65)
3400 (5775)	0.27 (67)





# Selection Information

▲ = Standard Feature    □ = Optional Feature (check the box to select this option)    Send finished selection to Aldes Canada.

## MODEL

Series: Advanced Commercial (CW)    Nominal Capacity: 2000-3400 CFM    Application:  Interior (i)     Exterior (e)

## CASING

### Cabinet Finish

- Painted
- Pool Construction

### Supply & Exhaust Hoods

- Optional (exterior models)

### Duct Configuration (see pg. 4)

- 1-2-6-7<sup>1</sup>     1-4-7-8
- 3-4-6-7<sup>1</sup>     1-4-6-7<sup>1</sup>
- 1-2-7-8     2-3-7-8
- 3-4-7-8     2-3-6-7<sup>1</sup>

### Mirror Image Cabinet

- Optional

### Roof Curb (exterior models)

- None
- Insulated
- Non-Insulated

## ELECTRICAL REQUIREMENTS

- 120V/1ph/60Hz
- 208V/1ph/60Hz
- 230V/1ph/60Hz
- 208V/3ph/60Hz
- 230V/3ph/60Hz
- 460V/3ph/60Hz
- 575V/3ph/60Hz

## FROST CONTROL

- None
- Exhaust Defrost<sup>2</sup>
- Recirculation<sup>2</sup>
- Pre-Heat (Electric Coil)
- Pre-Heat (Hot Water Coil)
- Wheel Speed Variation (VFD)

## BLOWERS & MOTORS

### Supply Blower

- 1 hp     3 hp
- 1.5 hp     5 hp
- 2 hp

### Exhaust Blower

- 1 hp     3 hp
- 1.5 hp     5 hp
- 2 hp

### Motor Type

- ODP, EPAAct<sup>3</sup>
- ODP, Premium<sup>4</sup>
- TEFC, EPAAct<sup>3</sup>
- TEFC, Premium<sup>5</sup>

### Blower Type

- Forward Curved
- Backward Inclined

### Blower Control

- Single Speed
- 2-Speed<sup>6</sup>
- Programmable 2-Speed (VFD)
- VFD

## HEATING OPTIONS

- None
- Post-Heat (Electric Coil)
- Post-Heat (Hot Water Coil)

## COOLING OPTIONS

- None
- Cold Water Cooling Coil
- DX Cooling Coil

## FILTERS

- MERV 8
- MERV 13 (Final Filter)

## ADD-ONS

- Mechanical Purge
- Motorized & Insulated Damper for EA
- Non-Insulated Backdraft Damper for EA
- Motorized & Insulated Damper for OA<sup>2</sup>
- Terminals for OA and/or EA damper power and control (24VAC, 10VA)
- Low Temperature Limit
- Economizer Cycle
- Dirty Filters Contact
- Low Airflow Switch
- Phase Loss Detection
- Wheel Rotation Detection
- Damper End Switch
- Recirculation Dry Contact<sup>7</sup>
- Programmable Timer
- CO<sub>2</sub> Sensor<sup>8</sup>
- Relative Humidity Sensor<sup>8</sup>
- BacNet Compatible Controller
  - With IP Module
  - With MS/TP Module
  - With Remote Keypad
  - With Remote Keypad (Touchscreen)
- Spare MERV 8 Filters QTY: \_\_\_\_\_
- Spare Belts QTY: \_\_\_\_\_

<sup>1</sup> Configuration not available with hoods option  
<sup>2</sup> OA Motorized & Insulated Damper included with exhaust defrost and recirculation  
<sup>3</sup> EPAAct efficiency only available when Premium efficiency is not available (e.g., with single-phase motors)  
<sup>4</sup> ODP, Premium only available with ≥ 3 hp/ 3ph motors  
<sup>5</sup> TEFC, Premium only available with ≥ 1.5 hp/ 3ph motors  
<sup>6</sup> 2-Speed only available with ODP, EPAAct motors  
<sup>7</sup> Recirculation Dry Contact requires selection of recirculation defrost  
<sup>8</sup> Sequence of operations must be verified by factory

Project:		Architect:	
Location:		Engineer:	
Model #:		Contractor:	
Quantity:		Comments:	
Submitted By:			
Date:			

2015 ALDES Canada. Reproduction or distribution, in whole or in part, of this document, in any form or by any means, without the express written consent of ALDES Canada, is strictly prohibited. The information contained within this document is subject to change without prior written notice.